

Low Voltage Differential (LVD/SE) SCSI 9 Line Terminator

FEATURES

- Auto Selection Multi-Mode Single Ended or Low Voltage Differential Termination
- 2.7V to 5.25V Operation
- Differential Failsafe Bias
- Thermal Packaging for Low Junction Temperature and Better MTBF
- Master/Slave Inputs
- Supports Active Negation
- Standby (Disable Mode) 5µA
- 3pF Channel Capacitance

DESCRIPTION

The UCC5630 Multi-Mode Low Voltage Differential and Single Ended Terminator is both a single ended terminator and a low voltage differential terminator for the transition to the next generation SCSI Parallel Interface (SPI-2). The low voltage differential is a requirement for the higher speeds at a reasonable cost and is the only way to have adequate skew budgets. The transceivers can be incorporated into the controller, unlike SCSI high power differential (EIA485) which requires external transceivers. Low Voltage differential is specified for Fast-40 and Fast-80, but has the potential of speeds up to Fast-320. The UCC5630 is SPI-2, SPI and Fast-20 compliant. Consult SSOP-36 and LQFP-48 Package Diagram for exact dimensions.

The UCC5630 can not be used with SCSI high voltage differential (HVD) EIA485. It will shut down when it sees high power differential to protect the bus. The pinning for high power differential is not the same as LVD or single ended and the bias voltage, current and power are also different for EIA485 differential.

BLOCK DIAGRAM

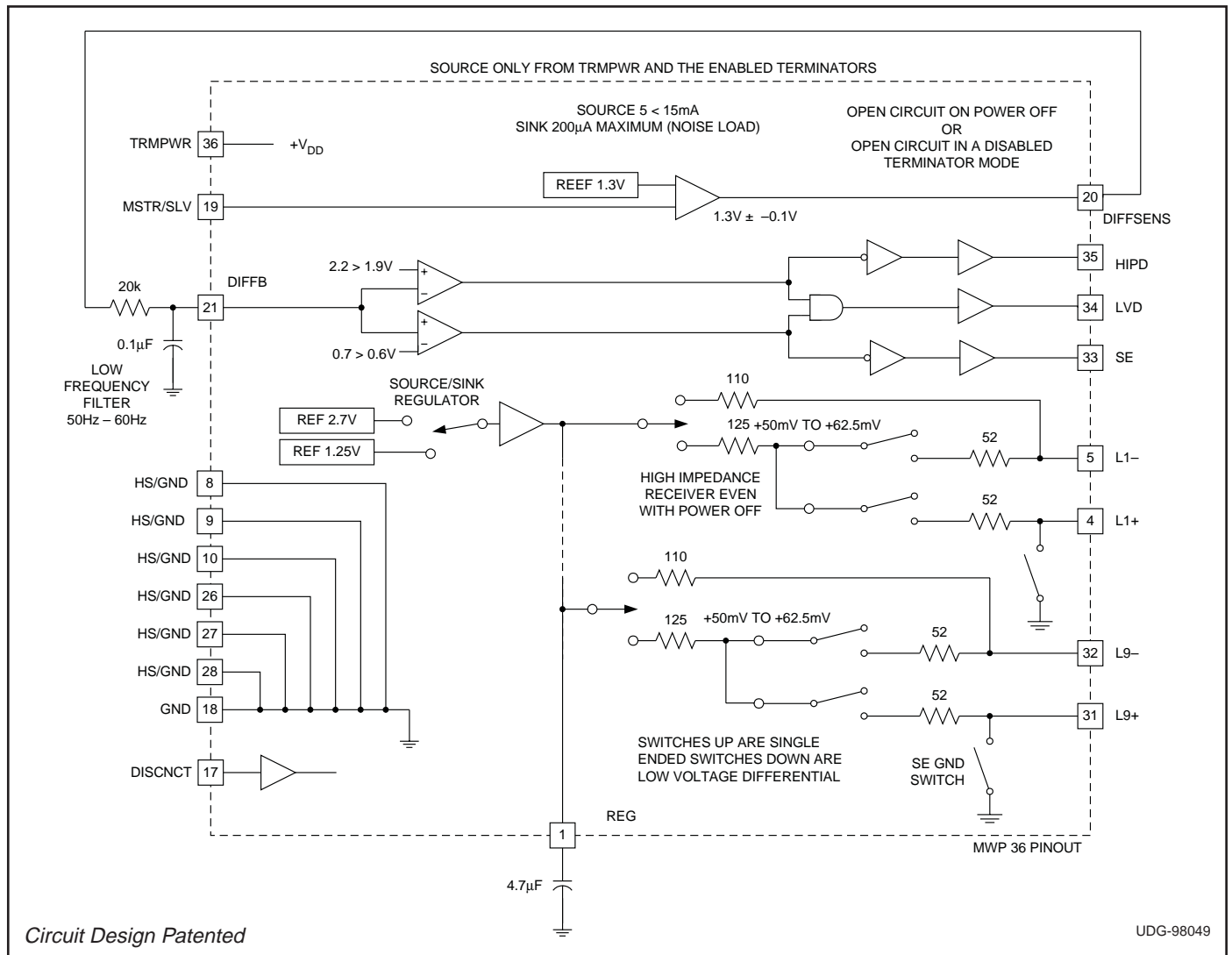

ABSOLUTE MAXIMUM RATINGS

TRMPWR Voltage 6V
 Signal Line Voltage 0V to TRMPWR
 Package Power Dissipation 2W
 Storage Temperature -65°C to +150°C
 Junction Temperature -55°C to +150°C
 Lead Temperature (Soldering, 10sec.) +300°C

All voltages are with respect to PIN1. Currents are positive into, negative out of the specified terminal. Consult Packaging Section of the Databook for thermal limitations and considerations of packages.

CONNECTION DIAGRAM

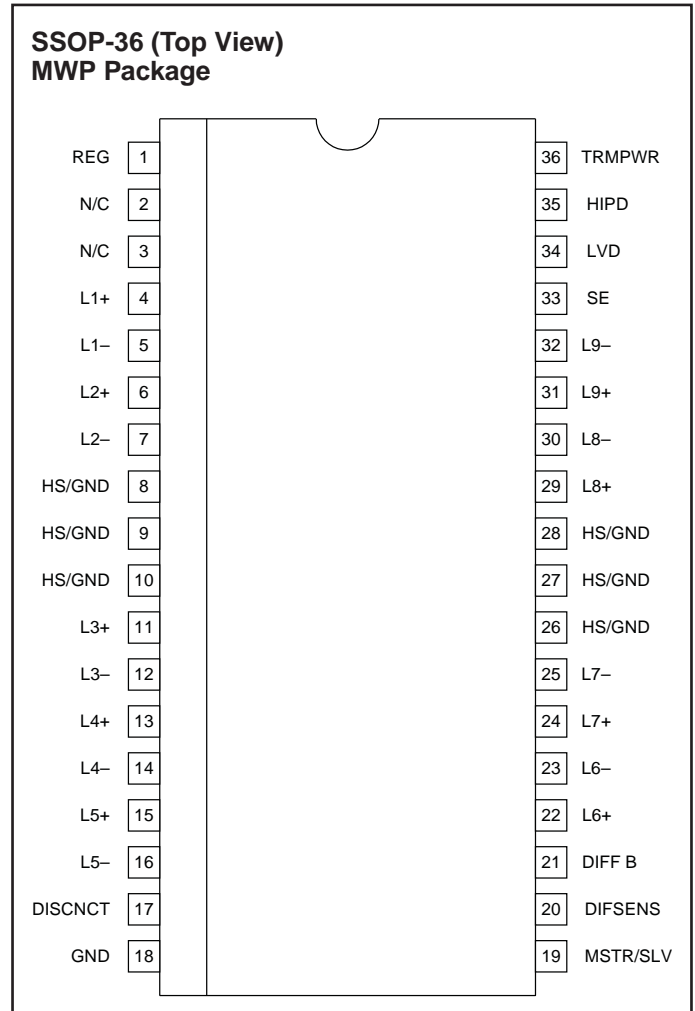
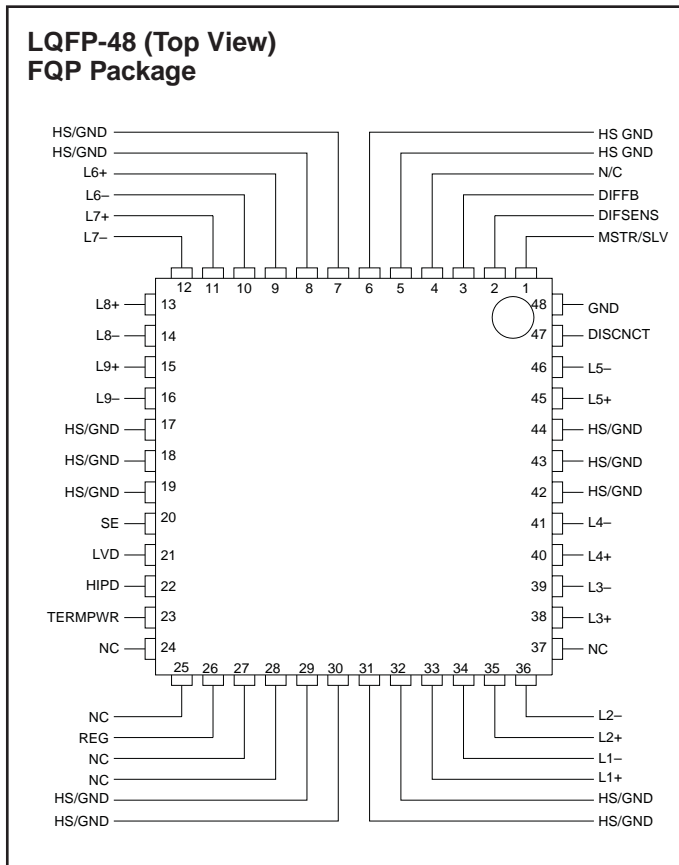

RECOMMENDED OPERATING CONDITIONS

TRMPWR Voltage 2.7V TO 5.25V

ELECTRICAL CHARACTERISTICS: Unless otherwise specified, T_A = 0°C to 70°C, TRMPWR = 3.3V.

PARAMETER	TEST CONDITIONS	MIN	TYP	MAX	UNITS
TRMPWR Supply Current Section					
TRMPWR Supply Current				20	mA
	Disable Terminator, in DISCNCT mode.			35	µA
Regulator Section					
1.25V Regulator	LVD Mode	1.15	1.25	1.35	V
1.25V Regulator Source Current	LVD Mode, Differential Sense Floating	-80	-100		mA
1.25V Regulator Sink Current	LVD Mode, Differential Sense Floating	80	100		mA
1.3V Regulator	DIFSENS	1.2	1.3	1.4	V
1.3V Regulator Source Current	DIFSENS	-5		-15	mA
1.3V Regulator Sink Current	DIFSENS	50		200	µA

ELECTRICAL CHARACTERISTICS: Unless otherwise specified, $T_A = 0^\circ\text{C}$ to 70°C , $\text{TRMPWR} = 3.3\text{V}$.

PARAMETER	TEST CONDITIONS	MIN	TYP	MAX	UNITS
2.7V Regulator	Single Ended Mode	2.5	2.7	3	V
2.7V Regulator Source Current	Single Ended Mode	-200	-400	-800	mA
2.7V Regulator Sink Current	Single Ended Mode	100	200	400	mA
2.7V Regulator Dropout Voltage	$V_{\text{TRMPWR}} - (V_{\text{REG}} - 2.7 \text{ Min})$			200	mV
Differential Termination Section					
Differential Impedance		100	105	110	Ω
Common Mode Impedance		110	125	165	Ω
Differential Bias Voltage	Drivers Tri-stated	100		125	mV
Common Mode Bias			1.25		V
Output Capacitance	Single Ended Measurement to Ground (Note 1)			3.5	pF
Single Ended Termination Section					
Impedance		102.3	110	117.7	Ω
Termination Current	Signal Level 0.2V	-21	-23	-25.4	mA
	Signal Level 0.5V			-22.4	mA
Output Leakage	Disabled, $\text{TRMPWR} = 0\text{V}$ to 5.25V			400	nA
Output Capacitance	Single Ended Measurement to Ground (Note 1)			3	pF
Single Ended GND SW Impedance				60	Ω
Disconnect (DISCNET) Input Section					
DISCNET Threshold		0.8		2.0	V
DISCNET Input Current	$V_{\text{DISCNET}} = 0\text{V}$ and 3.3V	-30		30	μA
Differential Sense (DIFFB) Input Sections					
DIFFB Single Ended Threshold		0.6		0.7	V
DIFFB Sense LVDS Threshold		1.9		2.2	V
DIFFB Input Current	$V_{\text{DIFFB}} = 0\text{V}$ and 3.3V	-30		30	μA
Master/Slave (MSTR/SLV) Input Section					
MSTR/SLV Threshold		0.8		2	V
MSTR/SLV Input Current		-30		30	μA
Status Bits (SE, LVD, HIPD) Output Section					
I_{SOURCE}	$V_{\text{LOAD}} = 2.4\text{V}$	-4	-8.7		mA
I_{SINK}	$V_{\text{LOAD}} = 0.5\text{V}$	3	6		mA
	$V_{\text{LOAD}} = 0.4\text{V}$	2	5		mA

Note 1: Guaranteed by design. Not 100% tested in production.

PIN DESCRIPTIONS

DIFFB: DIFSENS filter pin should be connected to a $0.1\mu\text{F}$ capacitor to GND and 20k resistor to SCSI/Bus DIFSENS Line.

DIFSENS: The SCSI bus DIFSENS line is driven to 1.3V to detect what type of devices are connected to the SCSI bus.

DISCNET: Disconnect shuts down the terminator when it is not at the ended of the bus. The disconnect pin low enables the terminator.

HIPD: TTL compatible status bit indicating high voltage differential has been detected on DIFFB. The terminator

is in shutdown. (Not valid in disconnect mode.)

HS/GND: Heat Sink GND. Connect to large area PC board traces to increase power dissipation capability.

GND: Power Supply Return.

L1- thru L9-: Signal line/active line for single ended or negative line in differential applications for the SCSI bus.

L1+ thru L9+: Ground line for single ended or positive line for differential applications for the SCSI bus.

LVD: TTL compatible status bit indicating low voltage differential level on DIFFB. The terminator is in LVD mode. (Not valid in disconnect mode.)

PIN DESCRIPTIONS (cont.)

MSTR/SLV: Mode select for the non-controlling terminator. MSTR enables the 1.3V regulator, when the terminator is enabled. Note: This function will be removed on further generations of the multimode terminators.

REG: Regulator bypass, must be connected to a 4.7μF

capacitor.

SE: TTL compatible status bit indicating single ended device has been detected on DIFFB. The terminator is in single ended mode.

TRMPWR: VIN 2.7V to 5.25V supply.

APPLICATION INFORMATION

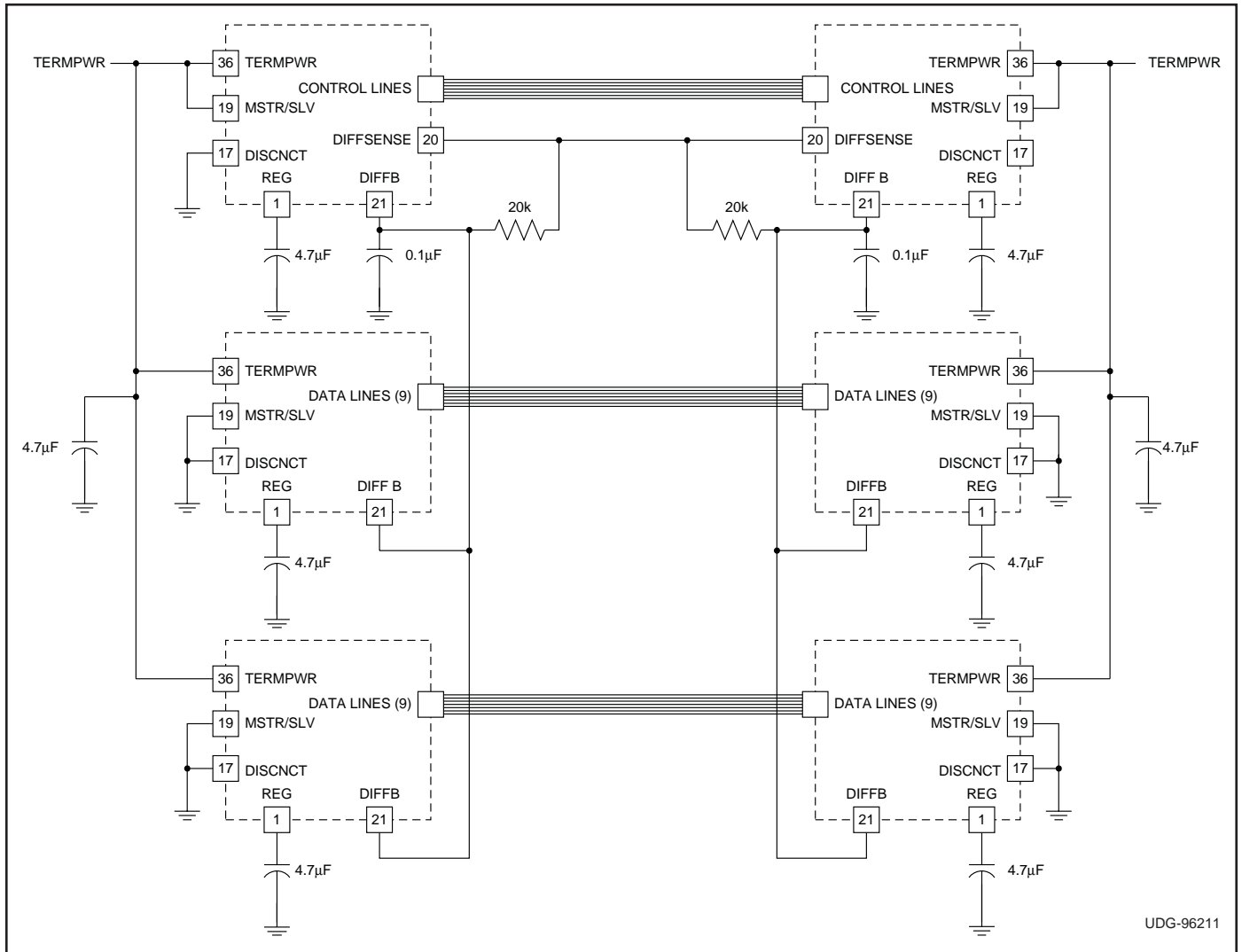

Balancing capacitor is very important in high speed operation. The typical balance between the positive (+) and negative (-) signals is 0.1pF except for L8 and L9, 0.23pF and 0.4pF respectively on the MWP package. The negative (-) signal has higher capacitance than the positive (+) signal. The FQP package is typically 0.2pF less than the MWP. Typical balance is 0.1pF except for L8 and L3, where it is 0.4pF.

The master is selected by placing TRMPWR on MSTR/SLV and the terminator enabled by grounding DISCNCT, enabling the 1.3V regulator. The master is the only terminator connected directly to DIFSENS bus line, all the other terminators receive the mode signal by connecting the DIFFB pins together.

Note: The Master/Slave function will not be on future terminators.

PACKAGING INFORMATION

Orderable Device	Status ⁽¹⁾	Package Type	Package Drawing	Pins	Package Qty	Eco Plan ⁽²⁾	Lead/Ball Finish	MSL Peak Temp ⁽³⁾
UCC5630FQP	OBSOLETE	LQFP	PT	48		TBD	Call TI	Call TI
UCC5630FQPTR	OBSOLETE	LQFP	PT	48		TBD	Call TI	Call TI
UCC5630MWP	OBSOLETE	SSOP	DCE	36		TBD	Call TI	Call TI
UCC5630MWPTR	OBSOLETE	SSOP	DCE	36		TBD	Call TI	Call TI

⁽¹⁾ The marketing status values are defined as follows:

ACTIVE: Product device recommended for new designs.

LIFEBUY: TI has announced that the device will be discontinued, and a lifetime-buy period is in effect.

NRND: Not recommended for new designs. Device is in production to support existing customers, but TI does not recommend using this part in a new design.

PREVIEW: Device has been announced but is not in production. Samples may or may not be available.

OBSOLETE: TI has discontinued the production of the device.

⁽²⁾ Eco Plan - The planned eco-friendly classification: Pb-Free (RoHS) or Green (RoHS & no Sb/Br) - please check <http://www.ti.com/productcontent> for the latest availability information and additional product content details.

TBD: The Pb-Free/Green conversion plan has not been defined.

Pb-Free (RoHS): TI's terms "Lead-Free" or "Pb-Free" mean semiconductor products that are compatible with the current RoHS requirements for all 6 substances, including the requirement that lead not exceed 0.1% by weight in homogeneous materials. Where designed to be soldered at high temperatures, TI Pb-Free products are suitable for use in specified lead-free processes.

Green (RoHS & no Sb/Br): TI defines "Green" to mean Pb-Free (RoHS compatible), and free of Bromine (Br) and Antimony (Sb) based flame retardants (Br or Sb do not exceed 0.1% by weight in homogeneous material)

⁽³⁾ MSL, Peak Temp. -- The Moisture Sensitivity Level rating according to the JEDEC industry standard classifications, and peak solder temperature.

Important Information and Disclaimer:The information provided on this page represents TI's knowledge and belief as of the date that it is provided. TI bases its knowledge and belief on information provided by third parties, and makes no representation or warranty as to the accuracy of such information. Efforts are underway to better integrate information from third parties. TI has taken and continues to take reasonable steps to provide representative and accurate information but may not have conducted destructive testing or chemical analysis on incoming materials and chemicals. TI and TI suppliers consider certain information to be proprietary, and thus CAS numbers and other limited information may not be available for release.

In no event shall TI's liability arising out of such information exceed the total purchase price of the TI part(s) at issue in this document sold by TI to Customer on an annual basis.

IMPORTANT NOTICE

Texas Instruments Incorporated and its subsidiaries (TI) reserve the right to make corrections, modifications, enhancements, improvements, and other changes to its products and services at any time and to discontinue any product or service without notice. Customers should obtain the latest relevant information before placing orders and should verify that such information is current and complete. All products are sold subject to TI's terms and conditions of sale supplied at the time of order acknowledgment.

TI warrants performance of its hardware products to the specifications applicable at the time of sale in accordance with TI's standard warranty. Testing and other quality control techniques are used to the extent TI deems necessary to support this warranty. Except where mandated by government requirements, testing of all parameters of each product is not necessarily performed.

TI assumes no liability for applications assistance or customer product design. Customers are responsible for their products and applications using TI components. To minimize the risks associated with customer products and applications, customers should provide adequate design and operating safeguards.

TI does not warrant or represent that any license, either express or implied, is granted under any TI patent right, copyright, mask work right, or other TI intellectual property right relating to any combination, machine, or process in which TI products or services are used. Information published by TI regarding third-party products or services does not constitute a license from TI to use such products or services or a warranty or endorsement thereof. Use of such information may require a license from a third party under the patents or other intellectual property of the third party, or a license from TI under the patents or other intellectual property of TI.

Reproduction of information in TI data books or data sheets is permissible only if reproduction is without alteration and is accompanied by all associated warranties, conditions, limitations, and notices. Reproduction of this information with alteration is an unfair and deceptive business practice. TI is not responsible or liable for such altered documentation.

Resale of TI products or services with statements different from or beyond the parameters stated by TI for that product or service voids all express and any implied warranties for the associated TI product or service and is an unfair and deceptive business practice. TI is not responsible or liable for any such statements.

Following are URLs where you can obtain information on other Texas Instruments products and application solutions:

Products		Applications	
Amplifiers	amplifier.ti.com	Audio	www.ti.com/audio
Data Converters	dataconverter.ti.com	Automotive	www.ti.com/automotive
DSP	dsp.ti.com	Broadband	www.ti.com/broadband
Interface	interface.ti.com	Digital Control	www.ti.com/digitalcontrol
Logic	logic.ti.com	Military	www.ti.com/military
Power Mgmt	power.ti.com	Optical Networking	www.ti.com/opticalnetwork
Microcontrollers	microcontroller.ti.com	Security	www.ti.com/security
		Telephony	www.ti.com/telephony
		Video & Imaging	www.ti.com/video
		Wireless	www.ti.com/wireless

Mailing Address: Texas Instruments
Post Office Box 655303 Dallas, Texas 75265