

RECOMMENDED PC BOARD LAYOUT

PBL PRODUCT

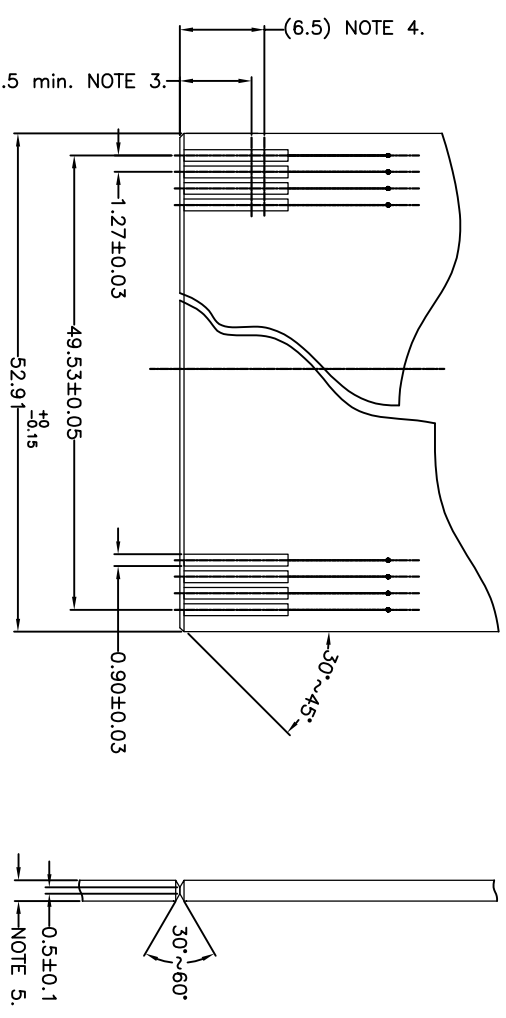

RECOMMENDED PCB DIMENSION

NOTE:

- △ MATERIAL:  
HOUSING: THERMOPLASTIC, UL94V-0, COLOR: BLACK.  
TIN PLATE: THERMOPLASTIC, UL94V-0, COLOR: BLACK.  
CONTACT: PHOSPHOR BRONZE, THICKNESS=0.30mm.  
RETENTION LEGS: BRASS, THICKNESS=0.50mm.
- △ FINISH:  
CONTACT: 0.38um MIN. GOLD PLATED IN CONTACT AREA.  
MATTIE TIN PLATED ON SOLDER TAIL.  
NICKEL UNDERPLATED ALL OVER.
- 3 GOLD PLATED ON MATING AREA.
- 4 INSERTION DEEP OF PCB.
- 5 THICKNESS OF PCB.
- 6 WAVE SOLDER CAPABLE TO 265° PER TYCO SPEC. 109-202, CONDITION B.

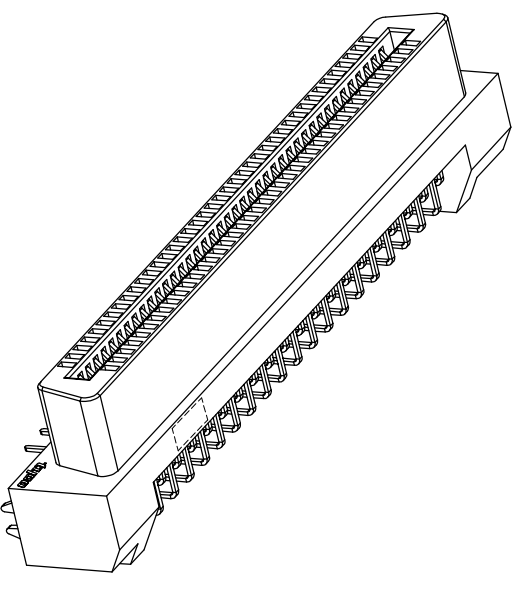

A

B

C

D

LOC	DIST	REV	DESCRIPTION	DATE	DMN	APPD
ES	-	P	LTR			
			SEE SHEET 1			

THIS DRAWING IS A CONTROLLED DOCUMENT.		DMN	tyco	
DIMENSIONS: mm		CHK	Tyco Electronics Corporation	
TOLERANCES UNLESS OTHERWISE SPECIFIED:		APD	Shanghai, P.R.China, 200233	
0 PLC	± 0.30	PRODUCT SPEC	CHAMP050 REC. CARD EDGE CONN. 80PIN, 4.8H	
1 PLC	± 0.30	108-57491		
2 PLC	± 0.30	APPLICATION SPEC		
3 PLC	± -			
4 PLC	± -			
FINISH ANGLES		SIZE	CAGE CODE	DRAWING NO
SEE CHART		A2	00779	1775024
MATERIAL		SCALE	1:1	SHEET 3 OF 4
△		RESTRICTED TO		

A

B

C

D

292433

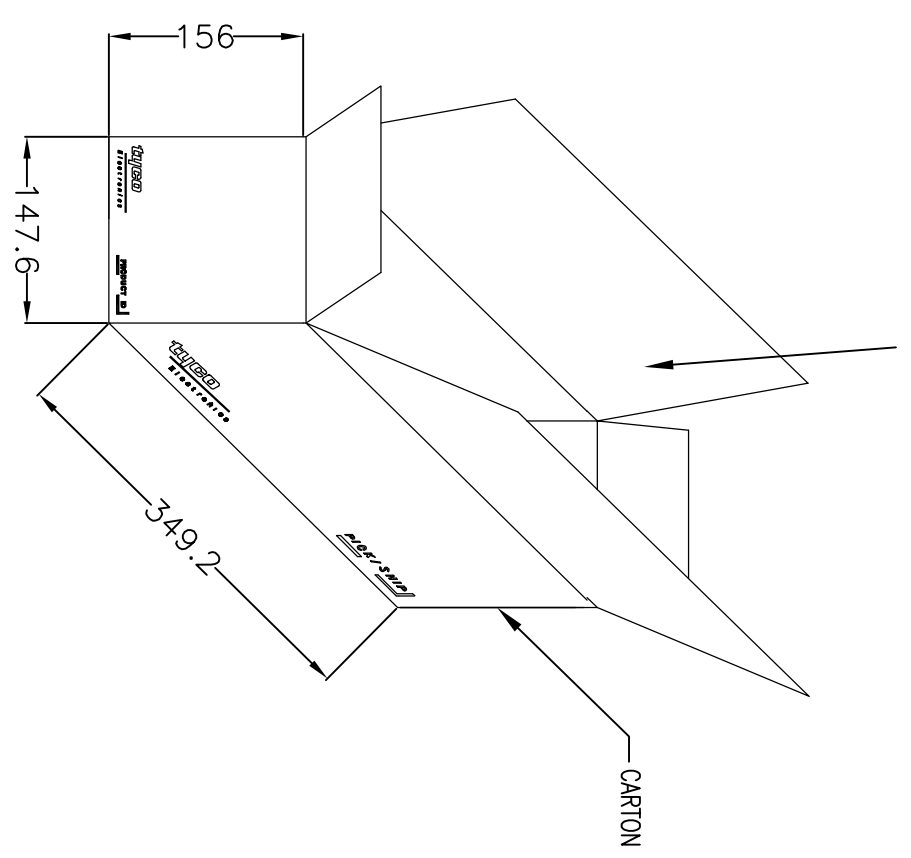
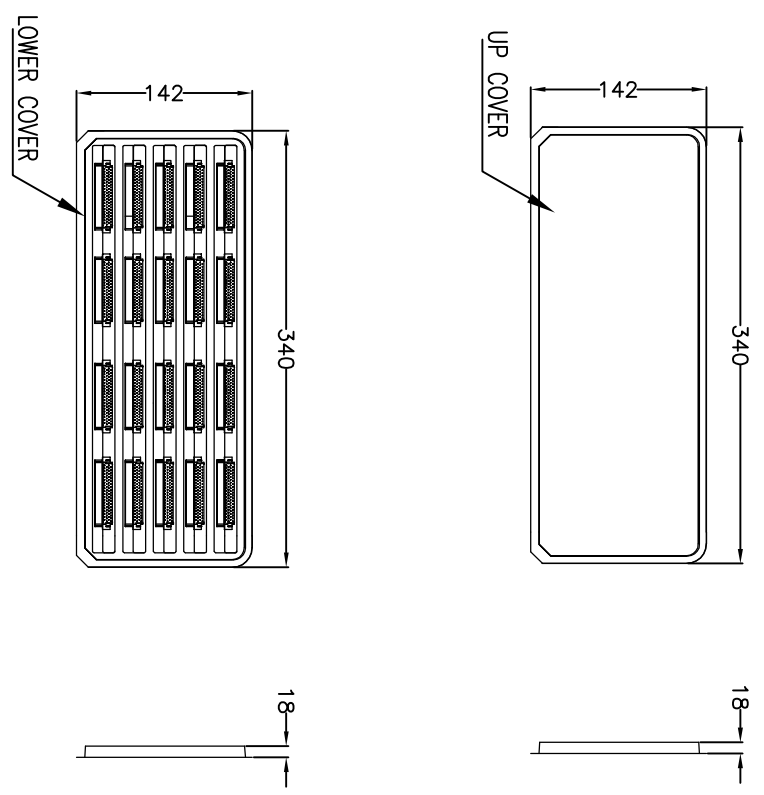
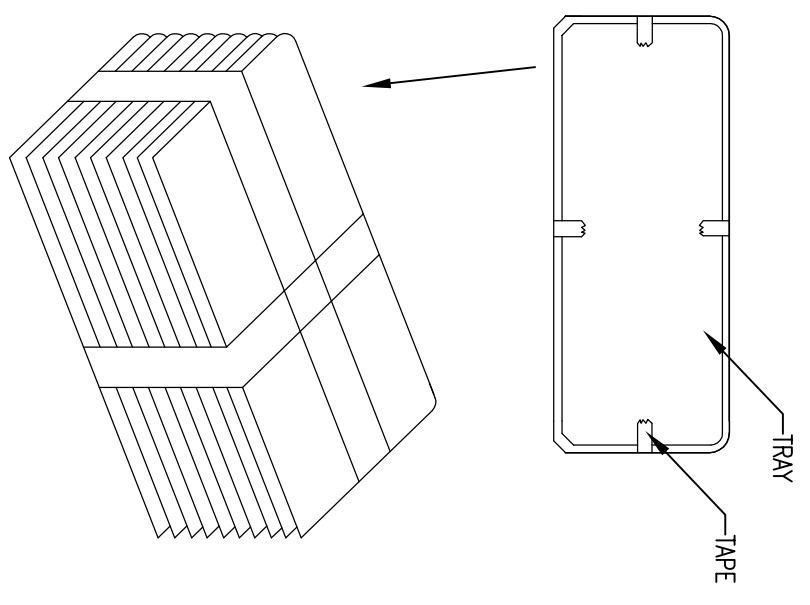

- NOTES :
- MATERIAL :
    - TRAY :PVC.
    - CARTON: CORRUGATED FIBER..
  - DIMENSION :
    - TRAY: L=340, W=142, H=18.
    - CARTON: L=349.2, W=147.6, H=156.
  - QUANTITY :
    - PRIMARY PACKING: 20PCS/TRAY.
    - SECONDARY PACKING: 8TRAY/CARTON(160PCS).
  - WEIGHT :
    - NET WEIGHT: 1.0kg/CARTON.
    - GROSS WEIGHT: 1.90kg/CARTON.

PBL PRODUCT

LOC	DIST	REV	DESCRIPTION	DATE	DMN	APPD
ES	-	P	SEE SHEET 1	-	-	-

1775024-2	PART NUMBER
1775024-1	PART NUMBER

1775024

THIS DRAWING IS A CONTROLLED DOCUMENT.		DMN	Tyco Electronics Corporation Shanghai, P.R.China, 200233	
DIMENSIONS: mm		CHK	APVD	
TOLERANCES UNLESS OTHERWISE SPECIFIED:		PRODUCT SPEC		
0 PLC	± 0.3	APPLICATION SPEC		
1 PLC	± 0.3	WEIGHT		
2 PLC	± -	CUSTOMER DRAWING		
3 PLC	± -	SIZE A2		
4 PLC	± -	CAGE CODE 00779		
FINISH		DRAWING NO 1775024		
MATERIAL		SCALE 1:1		
		SHEET 4 OF 4		
		REV G		