

Universe II™:

High Performance 64-bit VMEbus-to-PCI Interconnect

Product Feature Sheet

Features

- Industry-proven, high-performance 64-bit VMEbus interconnect
- Fully compliant, 32-bit or 64-bit, 33-MHz PCI bus interconnect
- Integral FIFOs for write posting to maximize bandwidth utilization
- Programmable DMA controller with Linked-list mode (scatter/gather) support
- Flexible interrupt logic
- Sustained transfer rates up to 60-70 MBps
- Extensive suite of VMEbus address and data transfer modes
- Automatic initialization for slave-only applications
- Flexible register set, programmable from both the PCI bus and VMEbus ports
- Full VMEbus system controller
- Support for Read Modify Write (RMW), Address Only with Handshake (ADOH), PCI LOCK # cycles, and semaphores
- IEEE 1149.1 JTAG

Benefits

- Provides high performance on the PCI bus
 - Zero-wait state implementation
 - Multi-beat transactions
 - Supports bus parking
- Features a wide range of VMEbus address and data transfer modes
 - A32/A24/A16 master and slave
 - D64/D32/D16/D08 master and slave
 - MBLT, BLT, ADOH, RMW, LOCK, location monitors
- Supports nine user programmable slave images on VMEbus and PCI bus ports
- Provides seven interrupt lines on either bus and flexible mapping of software and hardware sources of hardware interrupt
- Provides four mailboxes and location monitor for message oriented systems

Device Overview

Universe II supports the latest VME applications with its high performance 64-bit VMEbus interface and fully compliant, 32-bit or 64-bit, PCI bus interface. Its zero wait state implementation, multi-beat transactions, and support for bus parking ensure high performance on the PCI bus. The device is ideally suited for CPU boards functioning as both master and slave in the VMEbus system and that require access to PCI systems.



Absolute Maximum Ratings:

| | |
|---|--------------------------|
| DC Supply Voltage | -0.3 to 7 V |
| Input Voltage (V_{IN}) | -0.5V to V_{DD} +0.5 V |
| DC current Drain per pin Any single Input or Output | \pm 50mA |
| DC current Drain per pin Any paralleled outputs | \pm 100 mA |
| DC Current Drain V_{DD} and V_{SS} pins | \pm 75 mA |
| Storage Temperature T_{STG} | -40 °C to + 125 °C |

Typical Applications

- Single board computers
- Telecommunications equipment
- Test equipment
- Command and control systems
- Factory automation equipment
- Medical equipment
- Military
- Aerospace

Packaging

- 25 mm x 25 mm, 361-contact dimpled ceramic Ball Grid Array (DBGA)

Universe II™: High Performance 64-bit VMEbus-to-PCI Interconnect

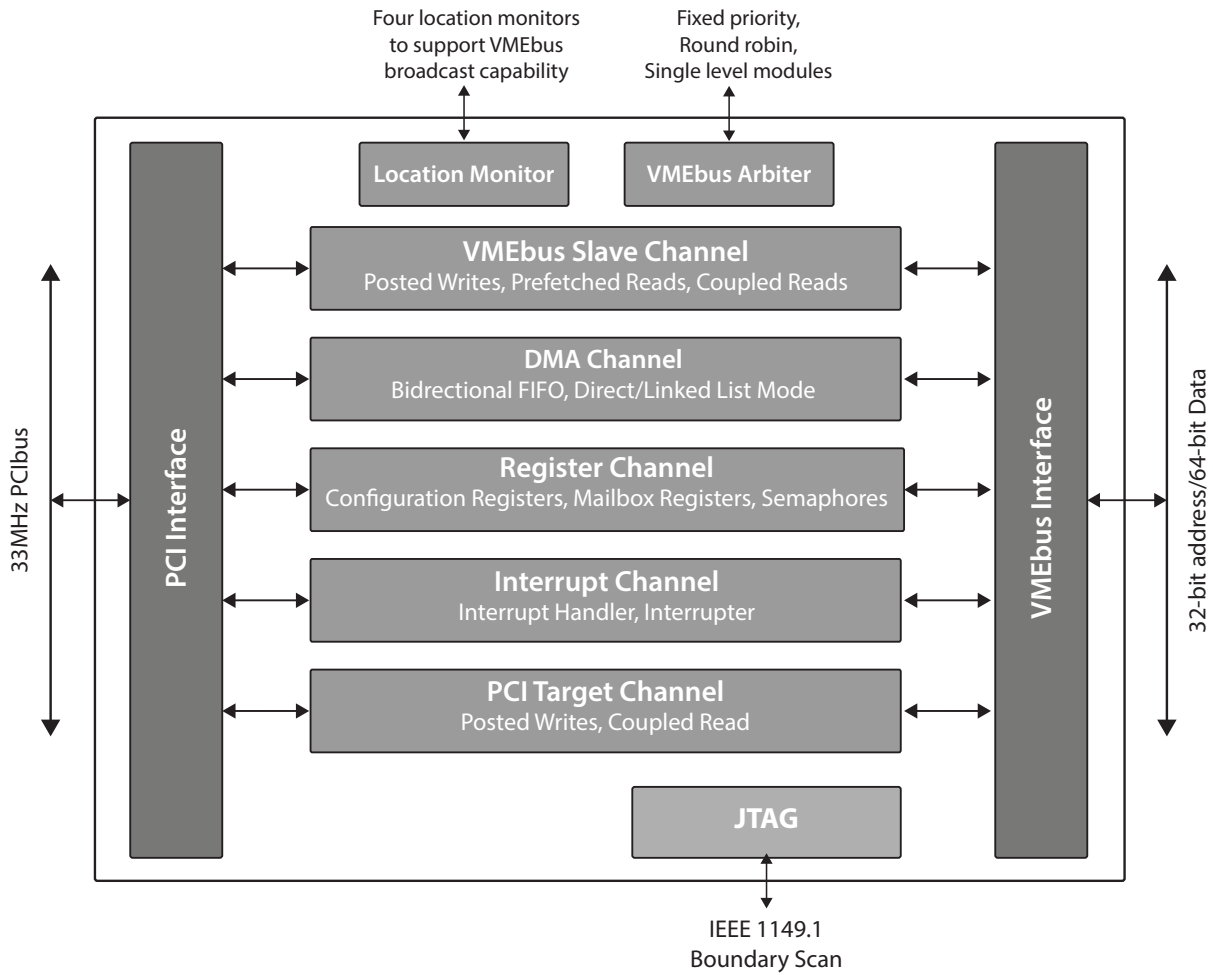

Functional Block Diagram

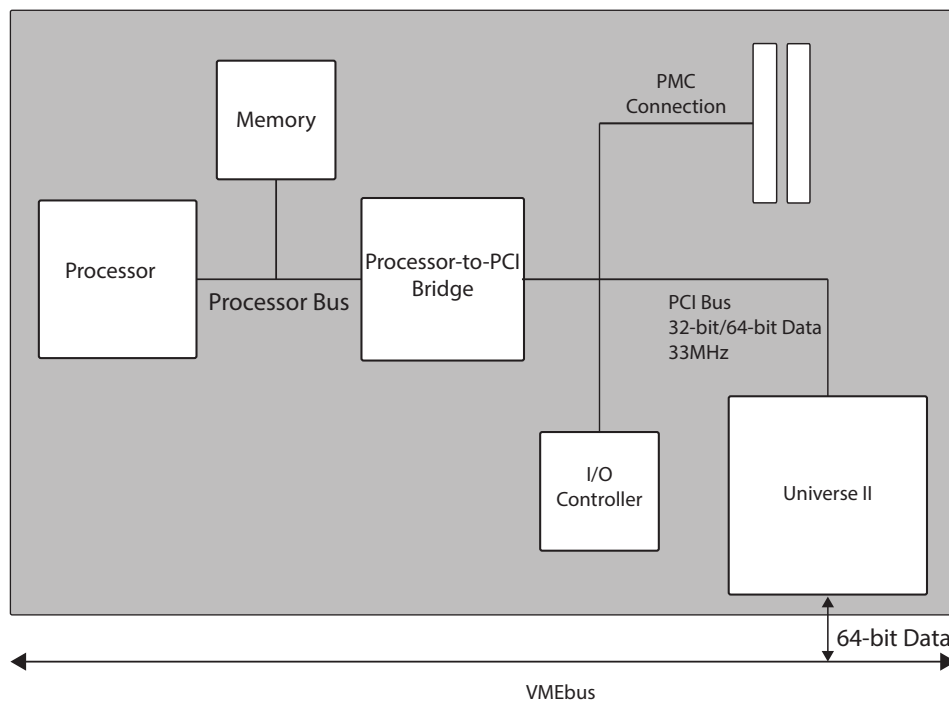

In Single Board Computer Application

Operating Conditions:

| Symbol | Parameter | Min | Max | Frequency Operation (MHZ) |
|--------------------------------|---------------------|----------|--------|---------------------------|
| V _{dd} | DC Supply Voltage | 4.5 V | 5.5 V | |
| T _a (Commerical) | Ambient Temperature | 0 °C | 70 °C | 25 - 33 MHz |
| T _a (Industrial) | Ambient Temperature | -40 °C t | 85 °C | 25 - 33 MHz |
| T _a (Extended) | Ambient Temperature | -55 °C | 125 °C | 25 MHz |

Typical Application: Single Board Computers

The Universe II is widely used on VME-based Single Board Computers (SBC) that employ PCI as their local bus and VME as the backplane bus, as shown in the diagram on the facing page. These SBC cards support a variety of applications including telecom, datacom, medical, industrial, and military equipment. The Universe II high performance architecture seamlessly bridges the PCI and VME buses, and is the VME industry standard for single board computer interconnect device.

Power Dissipation:

| Parameter | Rating |
|----------------------------|--------|
| IDLE | |
| Power Dissipation (32 Bit) | 1.97 W |
| Power Dissipation (64 Bit) | 2.12 W |
| TYPICAL | |
| Power Dissipation (32 Bit) | 2.65 W |
| Power Dissipation (64 Bit) | 3.15 W |

Ordering Information:

| Part # | PCI Frequency | Voltage | Temperature | Package |
|----------------|---------------|---------|------------------|----------------|
| CA91C142D-33CB | 33 MHz | 5 V | 0 °C to 70 °C | DBGA (ceramic) |
| CA91C142D-33IB | 33 MHz | 5 V | -40 °C to 85 °C | DBGA (ceramic) |
| CA91C142E-25EB | 25 MHz | 5 V | -55 °C to 125 °C | DBGA (ceramic) |



1804 McCarthy Blvd. | Milpitas, CA 95035 | 408.904.0200 | silicon360.com