

# DATA SHEET

**Class 2, 63 V and 100 V (DC)  
(flanged types)  
Miniature ceramic plate  
capacitors**

Product specification  
Supersedes data of 04 November 2002

2003 April 18

## Miniature ceramic plate capacitors

## Class 2, 63 V and 100 V (DC) (flanged types)

### FEATURES

- Filtering
- Coupling and decoupling
- Space saving.

### APPLICATIONS

In electronic circuits where non-linear change of capacitance with temperature is permissible and low losses are not essential, i.e. coupling and decoupling. Because of their small size the capacitors are suitable for use in circuitry with high component density.

### DESCRIPTION

The capacitors consist of a thin rectangular ceramic plate, both sides of which are metallized. The tinned connecting leads are secured using a high melting point solder. The capacitors are encapsulated in epoxy lacquer, which is resistant to all commonly used cleaning solvents. They have small dimensions and narrow tolerances on the lead spacing. The leads are provided with a flange, which guarantees that the leads are free of lacquer, and its shape allows soldering gasses to escape freely, ensuring excellent solderability. This makes the capacitors suitable for both hand-mounting and automatic insertion.

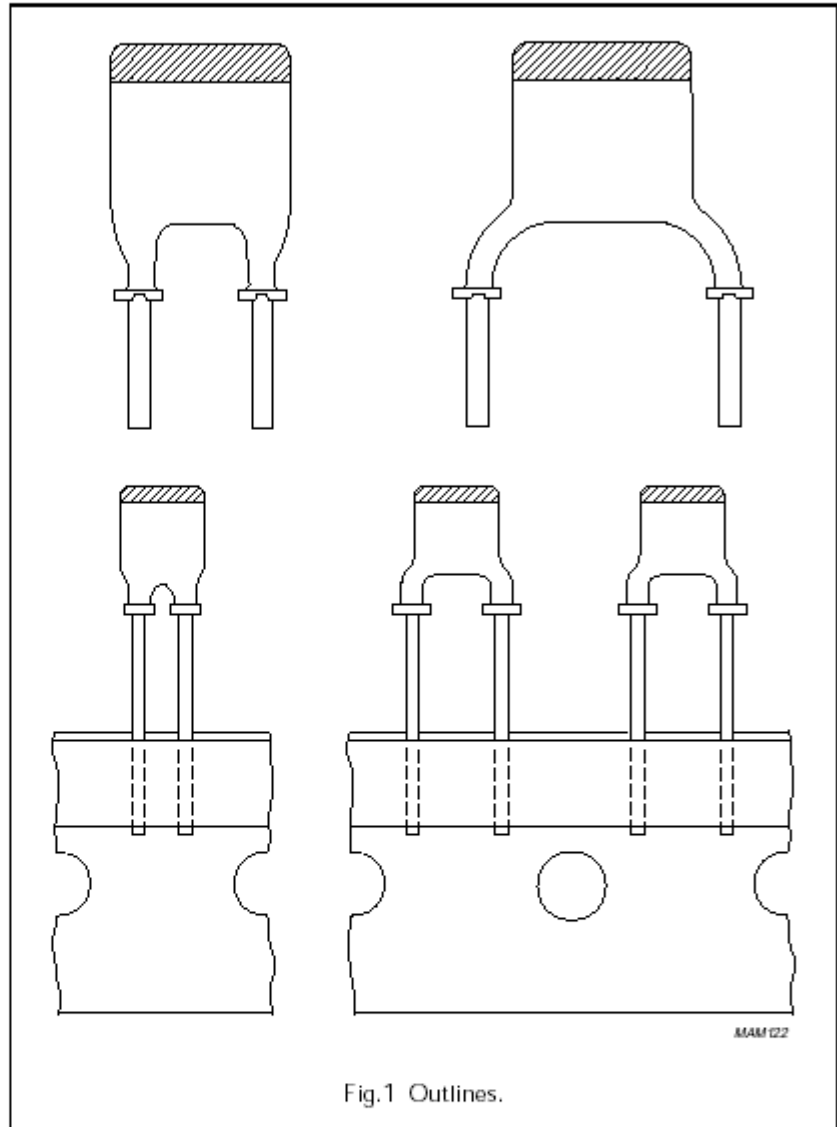

Fig.1 Outlines.

### QUICK REFERENCE DATA

DESCRIPTION	VALUE		
	2222 630 .....	2222 640 .....	2222 629 .....
Capacitance range	180 to 1000 pF (E12 series)	1000 to 15000 pF (E6 series)	1000 to 47000 pF (E3 series)
Dielectric material	K2000	K5000	K14000
Rated DC voltage	100 V	100 V	63 V
Tolerance on capacitance	±10%	+50%/-20%	+80%/-20%
Sectional specification	IEC 60384-9 (2C2 and 2D1); EIA (X5S/X7T)	IEC 60384-9 (2E2); EIA (X5U)	IEC 60384-9 (2F6); EIA (Y5V)
Climatic category (IEC 60068)	55/125/56	55/105/21	10/085/21

**Miniature ceramic plate capacitors**

**Class 2, 63 V and 100 V (DC)  
(flanged types)**

MECHANICAL DATA

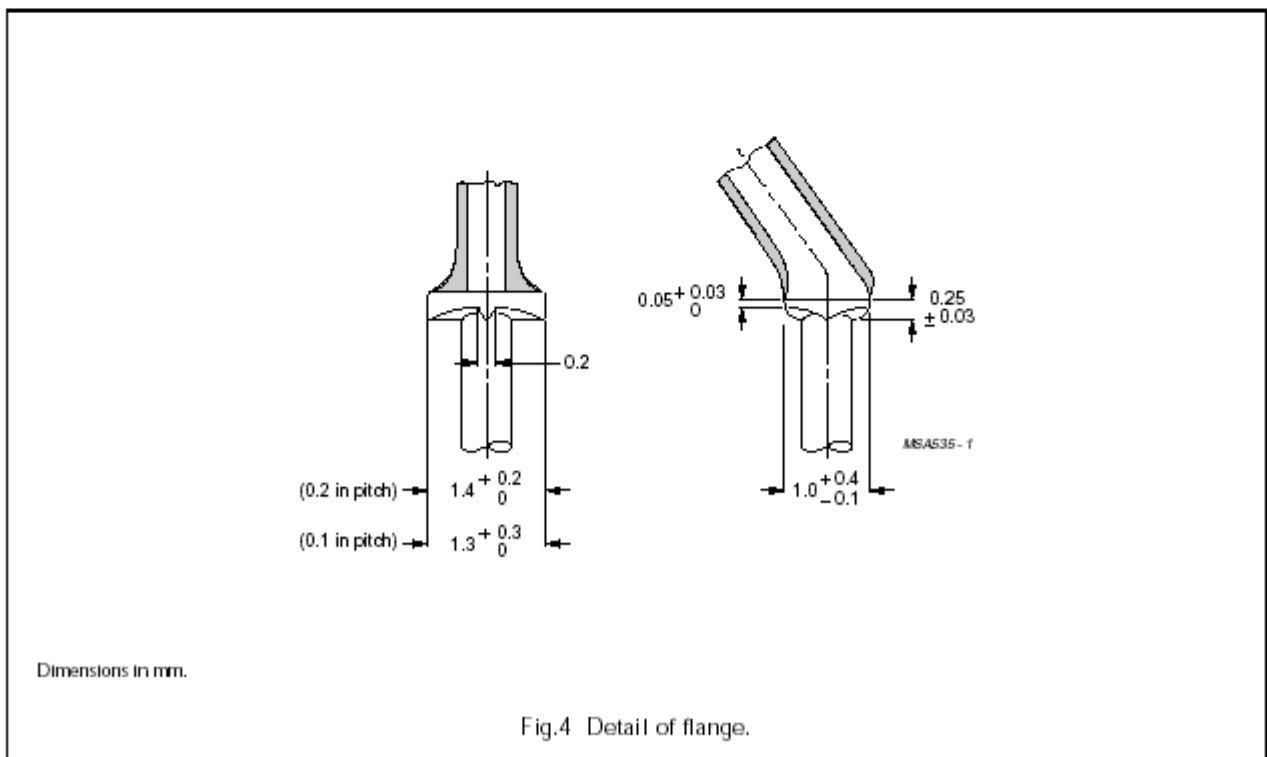
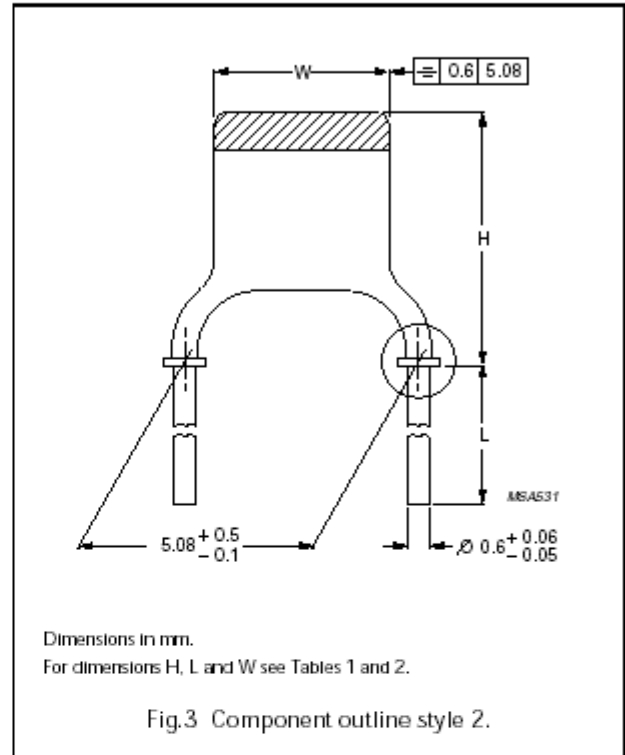
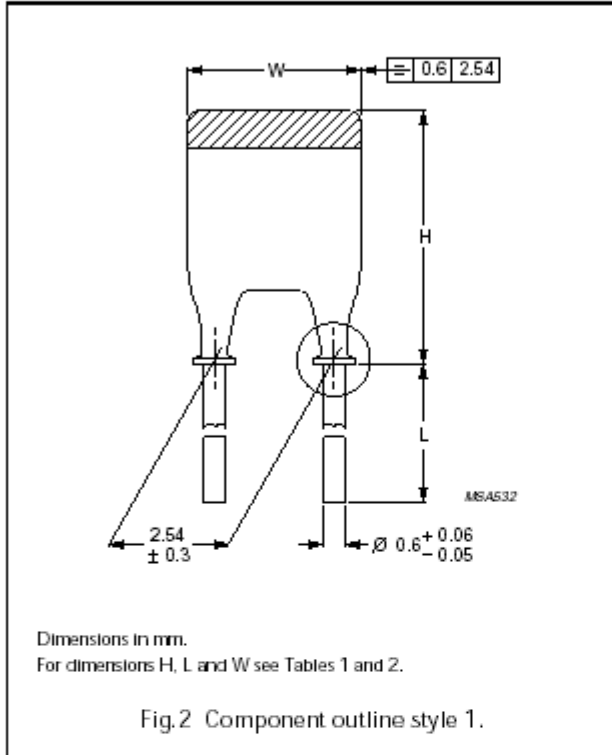

## Miniature ceramic plate capacitors

## Class 2, 63 V and 100 V (DC) (flanged types)

### Marking

The body of the capacitor is tan coloured. The temperature characteristic is indicated by a marking code on the body in accordance with IEC recommendations. Capacitance value is indicated by a marking code on the body. Refer to tables 3 to 5 for temperature characteristics and capacitance marking codes.

### Mounting

When bending, cutting or flattening, the leads should be relieved of the applied load by supporting them at the capacitor body.

Soldering conditions:

max. 265 °C, max. 10 s.

The capacitors are suitable for mounting on printed-circuit boards (hand-mounting or automatic insertion).

### ORDERING INFORMATION

Table 2 Catalogue numbers

PITCH P	LEAD DIAMETER d	STYLE	CATALOGUE NUMBERS <sup>(1)</sup>			
			BULK PACKED		ON TAPE <sup>(2)</sup> (REEL)	ON TAPE <sup>(2)</sup> (AMMOPACK)
			L ≥ 13 mm	L = 4 ±0.5 mm		
2.54 mm (0.1 inch)	0.6 mm (0.024 inch)	1	2222 630 08...	2222 630 18...	2222 630 51...	2222 630 61...
			2222 640 08...	2222 640 18...	2222 640 51...	2222 640 61...
			2222 629 08...	2222 629 18...	2222 629 51...	2222 629 61...
5.08 mm (0.2 inch)	0.6 mm (0.024 inch)	2	2222 630 09...	2222 630 19...	2222 630 53...	2222 630 63...
			2222 640 09...	2222 640 19...	2222 640 53...	2222 640 63...
			2222 629 09...	2222 629 19...	2222 629 53...	2222 629 63...

### Notes

- Catalogue number to be completed by adding the 3-digit suffix for required capacitance value, see Tables 3, 4 and 5.
- H<sub>0</sub> = 18.25 mm.

### Physical dimensions

Table 1 Capacitor dimensions and mass

SIZE <sup>(1)</sup>	W <sup>(2)</sup> (mm)	H <sup>(2)</sup> (mm)		MASS (g)
		STYLE 1	STYLE 2	
I	3.6 (-1.1)	5.0 (-1.5)	6.3 (-1.8)	≈0.14
IIA	3.9 (-1.4)	5.3 (-1.7)	6.7 (-2.0)	≈0.15
IIB	4.5 (-1.8)	6.0 (-2.1)	7.3 (-2.4)	≈0.15
III	5.3 (-1.8)	6.8 (-2.3)	8.1 (-2.6)	≈0.17
IV	6.2 (-2.0)	7.7 (-2.4)	9.0 (-2.7)	≈0.20
V	6.2 (-2.0)	10.3 (-2.8)	11.2 (-3.1)	≈0.23
VI	6.5 (-2.3)	12.3 (-3.5)	13.2 (-3.8)	≈0.25

### Notes

- Unless indicated in Tables 3, 4 and 5, the thickness of the capacitors does not exceed 2.3 mm.
- Tolerances are given between parentheses.

### PACKAGING

For details refer to this handbook, chapter "Miniature ceramic plate capacitors", section "General data".

## Miniature ceramic plate capacitors

## Class 2, 63 V and 100 V (DC) (flanged types)

Table 3 Preferred capacitance range for 2222 630 .....

CAPACITANCE VALUE (pF)	SIZE (see Table 1)	MARKING	SUFFIX OF CATALOGUE NUMBER (see Table 2)
180	I <sup>(1)</sup>	n18	181
220	I <sup>(1)</sup>	n22	221
270	I	n27	271
330	I	n33	331
390	I	n39	391
470	I	n47	471
560	I	n56	561
680	I	n68	681
820	I	n82	821
1000	I	1n0	102
1200	IIA	1n2	122
1500	IIA	1n5	152
1800	IIB	1n8	182
2200	IIB	2n2	222
2700	III	2n7	272
3300	III	3n3	332
3900	IV	3n9	392
4700	IV	4n7	472
5600	V	5n6	562
6800	V	6n8	682
8200	VI	8n2	822
10 000	VI	10n	103

### Note

1. Maximum thickness 2.5 mm.

## Miniature ceramic plate capacitors

## Class 2, 63 V and 100 V (DC) (flanged types)

Table 4 Preferred capacitance range for 2222 640 .....

CAPACITANCE VALUE (pF)	SIZE (see Table 1)	MARKING	SUFFIX OF CATALOGUE NUMBER (see Table 2)
1000	I	1n0	102
1500	I	1n5	152
2200	I	2n2	222
3300	IIA	3n3	332
4700	IIB	4n7	472
6800	III	6n8	682
10000	IV	10n	103
15000	V	15n	153

Table 5 Preferred capacitance range for 2222 629 .....

CAPACITANCE VALUE (pF)	SIZE (see Table 1)	MARKING	SUFFIX OF CATALOGUE NUMBER (see Table 2)
1000	I	1n0	102
2200	I	2n2	222
4700	I	4n7	472
10000	IIB	10n	103
22000	IV	22n	223
47000	V	47n	473

## Miniature ceramic plate capacitors

## Class 2, 63 V and 100 V (DC) (flanged types)

### ELECTRICAL CHARACTERISTICS

Capacitors 2222 630 (TC code 2C2)

The capacitors meet the essential requirements of "IEC 60384-8" (2C2 and 2D1) "EIA" (X5S and X7T). Unless stated otherwise all electrical values apply at an ambient temperature of  $20 \pm 1$  °C, an atmospheric pressure of 86 to 106 kPa and a relative humidity of 63 to 67%.

DESCRIPTION	VALUE
Capacitance values measured at 1 kHz, 1 V	180 to 6800 pF; E12 series (see Table 3)
Dielectric material	K2000
Tolerance on capacitance, after 1000 hours	$\pm 10\%$
Maximum capacitance change with respect to capacitance value at 20 °C	+20 to -20% (see Fig.5) from -55 to +85 °C; +20 to -30% from -55 to +125 °C
Rated DC voltage	100 V
DC test voltage; duration 1 minute	300 V
DC test voltage of coating; duration 1 minute	300 V
Insulation resistance at 100 V (DC) after 1 minute	$\geq 4\,000\text{ M}\Omega$
Tan $\delta$ measured at 1 kHz, 1 V	$\leq 3.5\%$
Maximum voltage dependency of the capacitance between 0 and 40 V	-5%
Category temperature range	-55 to +85 °C (2C2) and -55 to +125 °C (2D1)
Ageing	typical 1.5% per time decade
Climatic category (IEC 60068)	55/125/56

**Miniature ceramic plate capacitors**

**Class 2, 63 V and 100 V (DC) (flanged types)**

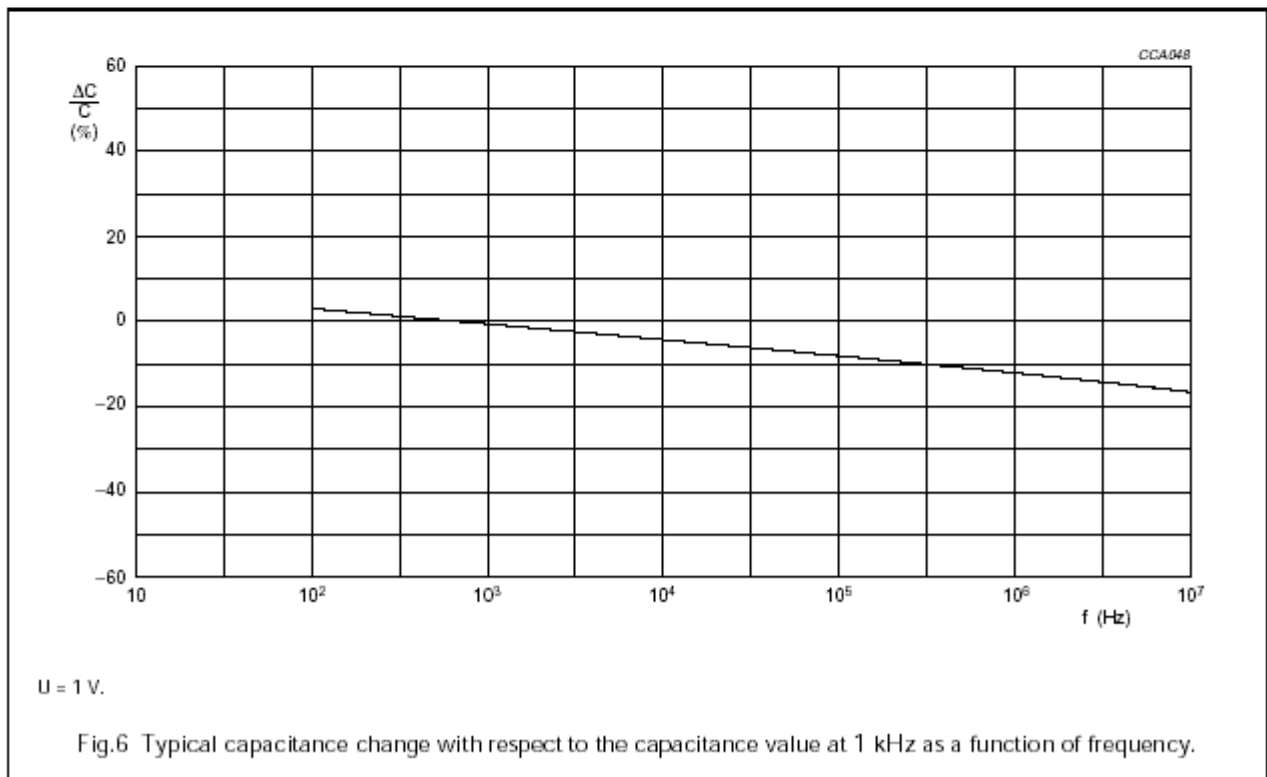
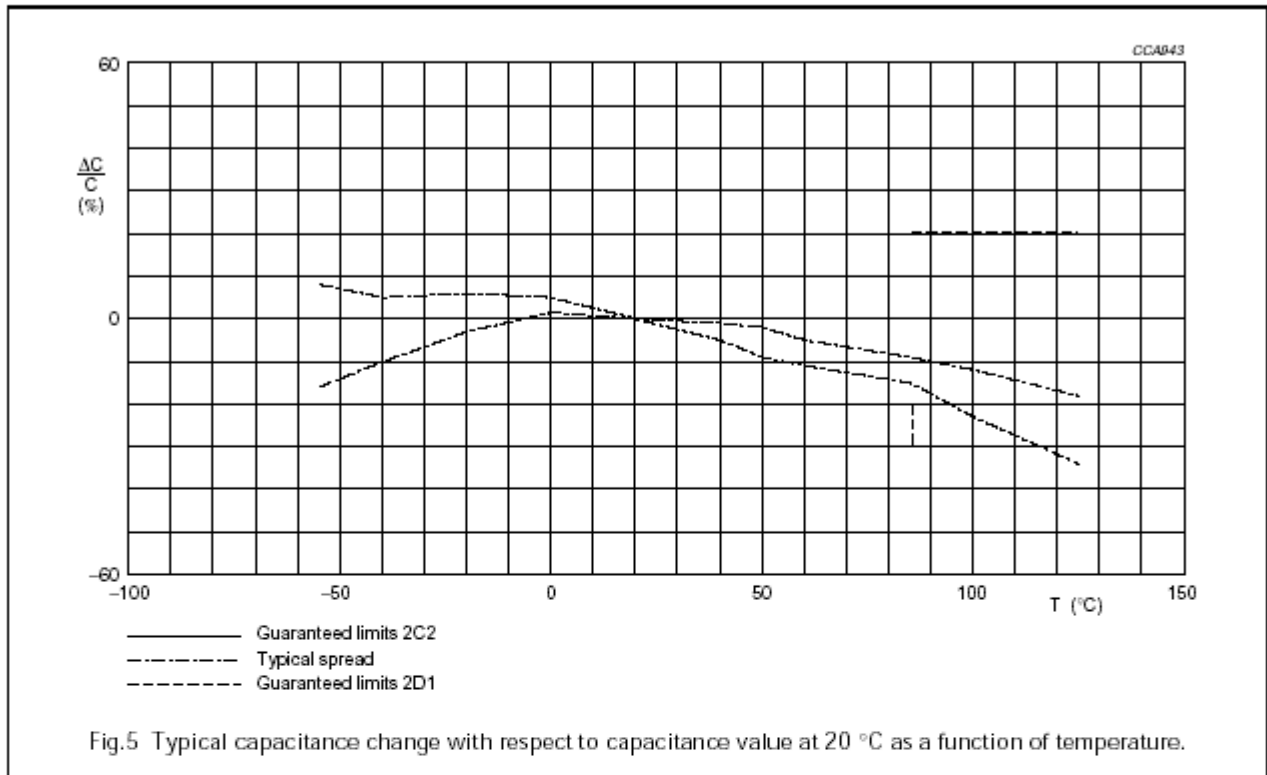



**Miniature ceramic plate capacitors**

**Class 2, 63 V and 100 V (DC) (flanged types)**

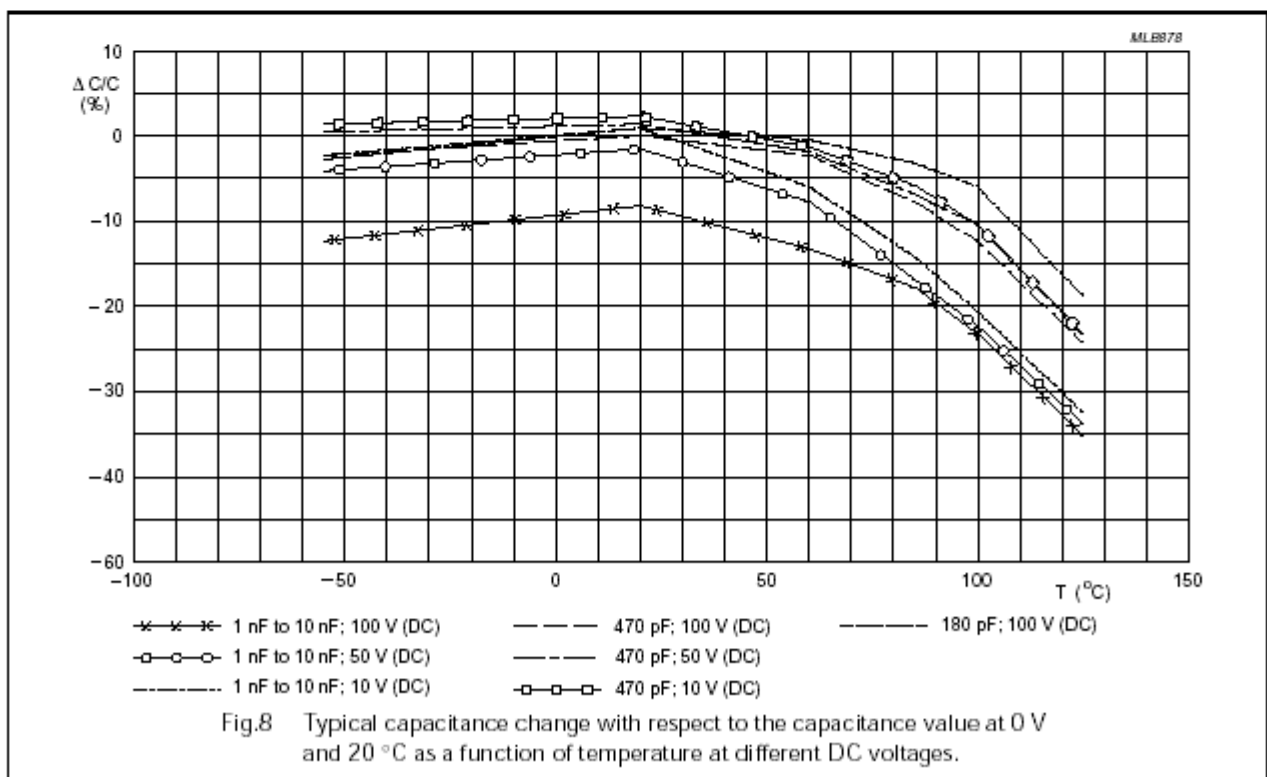
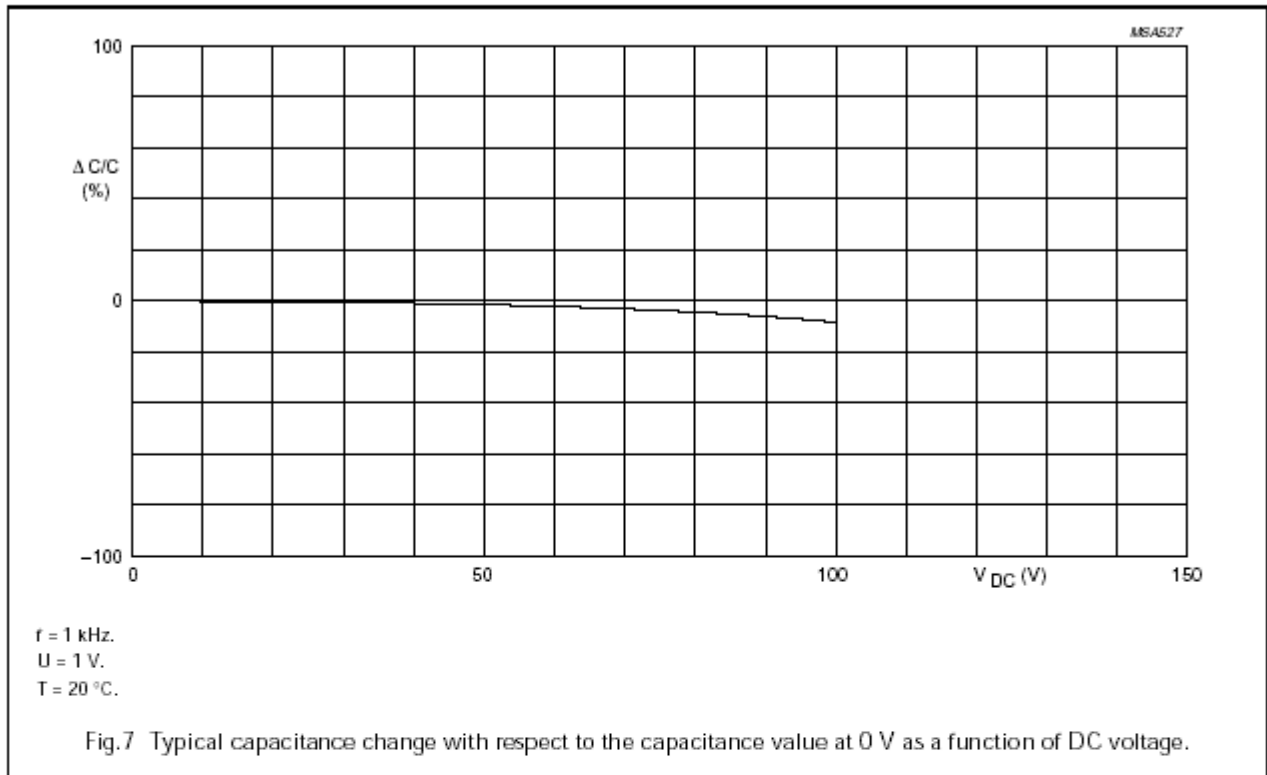

**Miniature ceramic plate capacitors**

**Class 2, 63 V and 100 V (DC) (flanged types)**

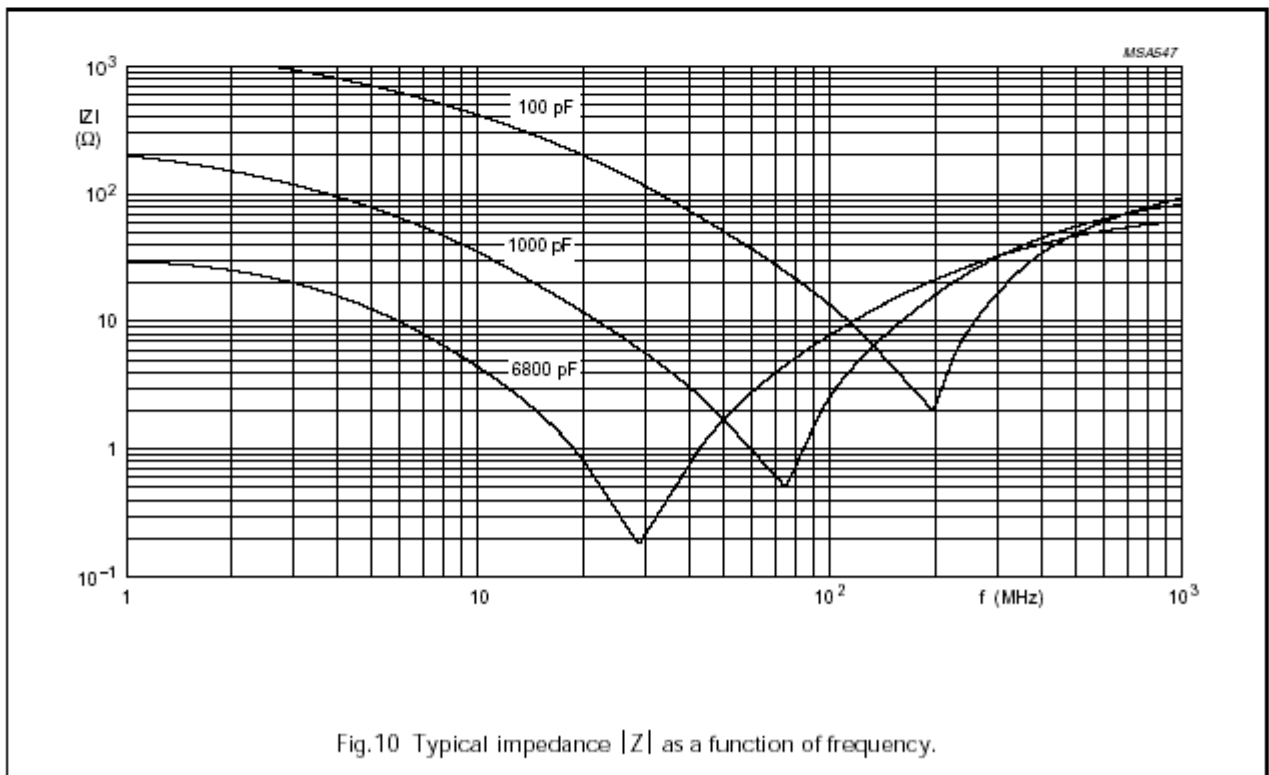
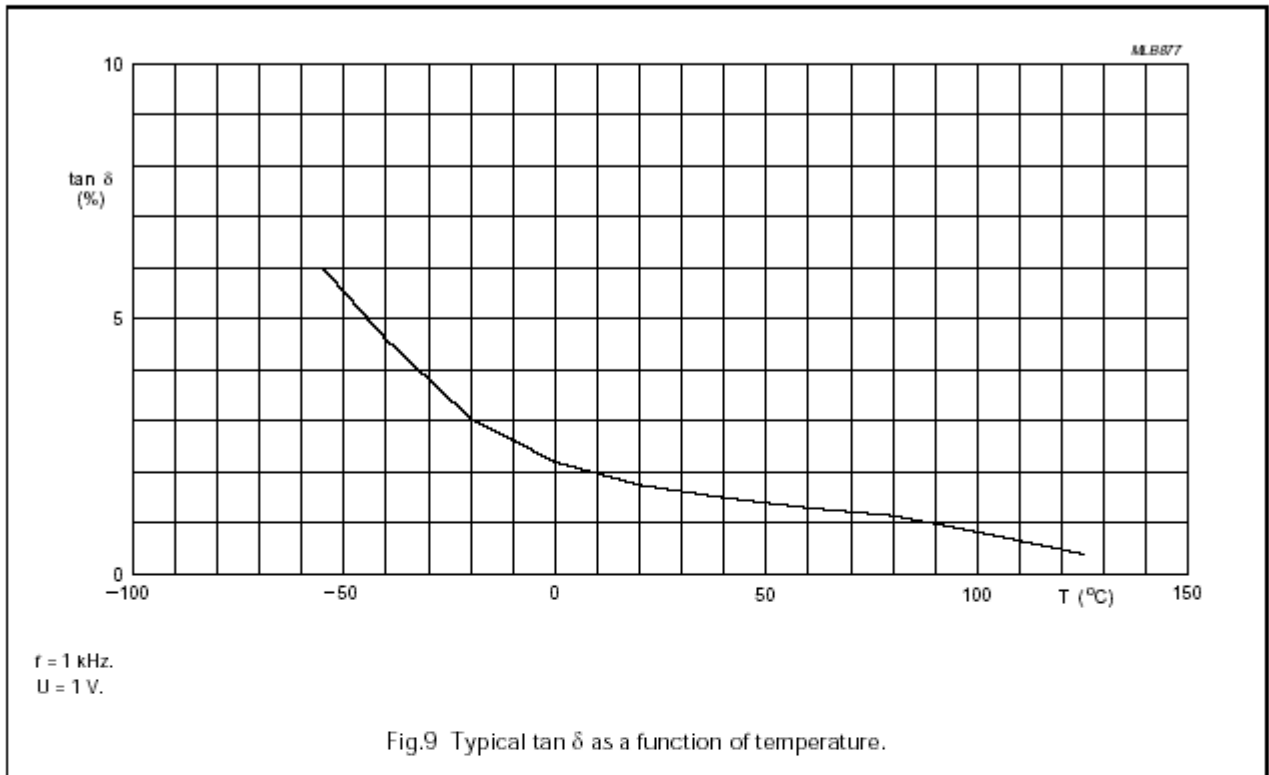

## Miniature ceramic plate capacitors

## Class 2, 63 V and 100 V (DC) (flanged types)

### Capacitors 2222 640 (TC code 2E2)

The capacitors meet the essential requirements of "IEC 60384-9" (2E2), "EIA" (X5U). Unless stated otherwise all electrical values apply at an ambient temperature of  $20 \pm 1$  °C, an atmospheric pressure of 86 to 106 kPa and a relative humidity of 63 to 67%.

DESCRIPTION	VALUE
Capacitance values measured at 1 kHz, 1 V	1000 to 15000 pF; E6 series (see Table 4)
Tolerance on capacitance, after 1000 hours	-20 to +50%
Dielectric material	K5000
Maximum capacitance change with respect to capacitance value at 20 °C	+20 to -55% (see Fig.11)
Rated DC voltage	100 V
DC test voltage; duration 1 minute	300 V
DC test voltage of coating; duration 1 minute	300 V
Insulation resistance at 100 V (DC) after 1 minute	$\geq 4000$ M $\Omega$
Tan $\delta$ measured at 1 kHz, 1 V	$\leq 3.5\%$
Category temperature range	-55 to +105 °C
Ageing	typical 5% per time decade
Climatic category (IEC 60068)	55/105/21

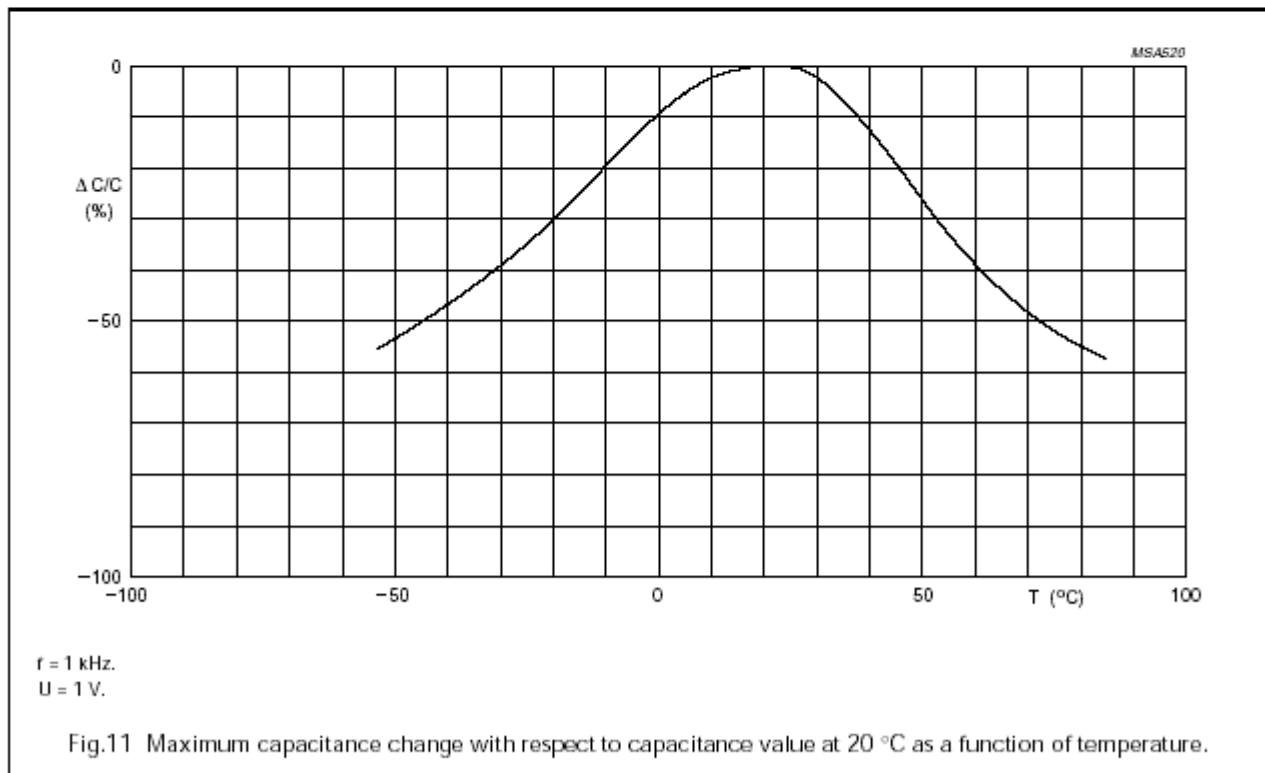

**Miniature ceramic plate capacitors**

**Class 2, 63 V and 100 V (DC) (flanged types)**

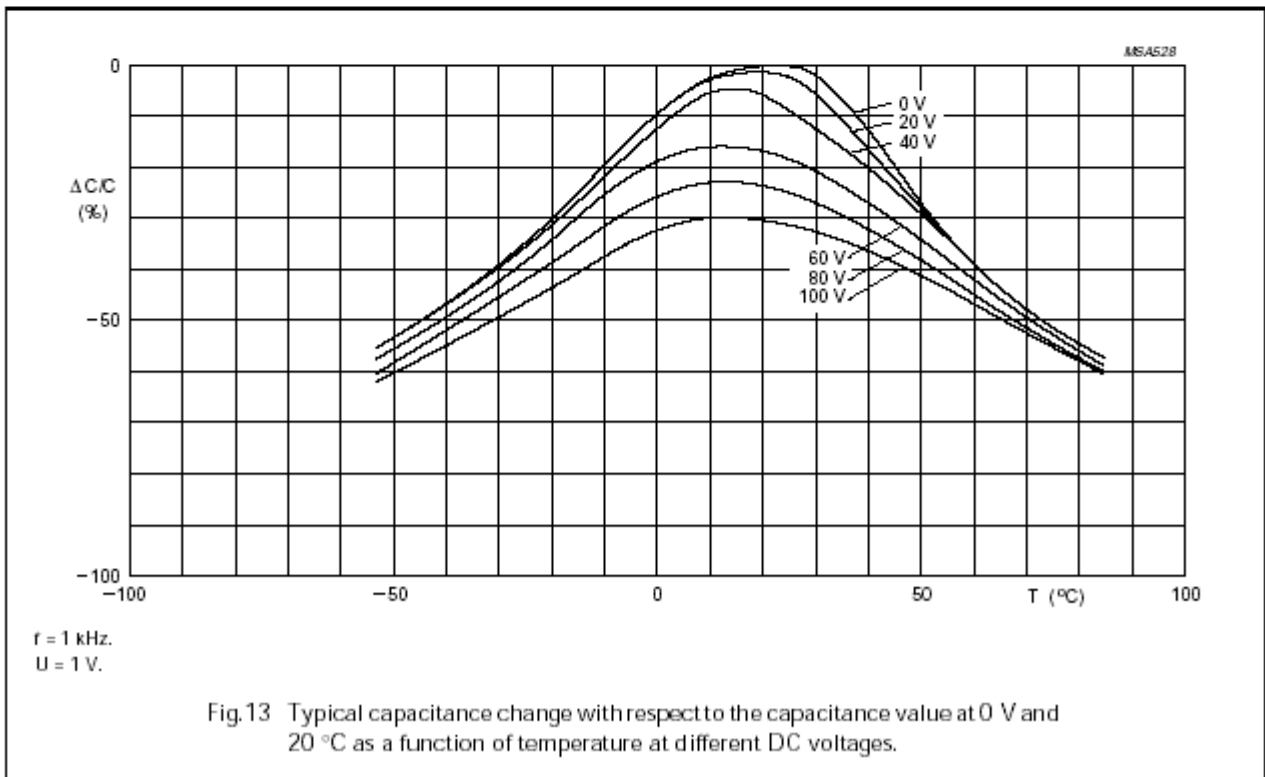
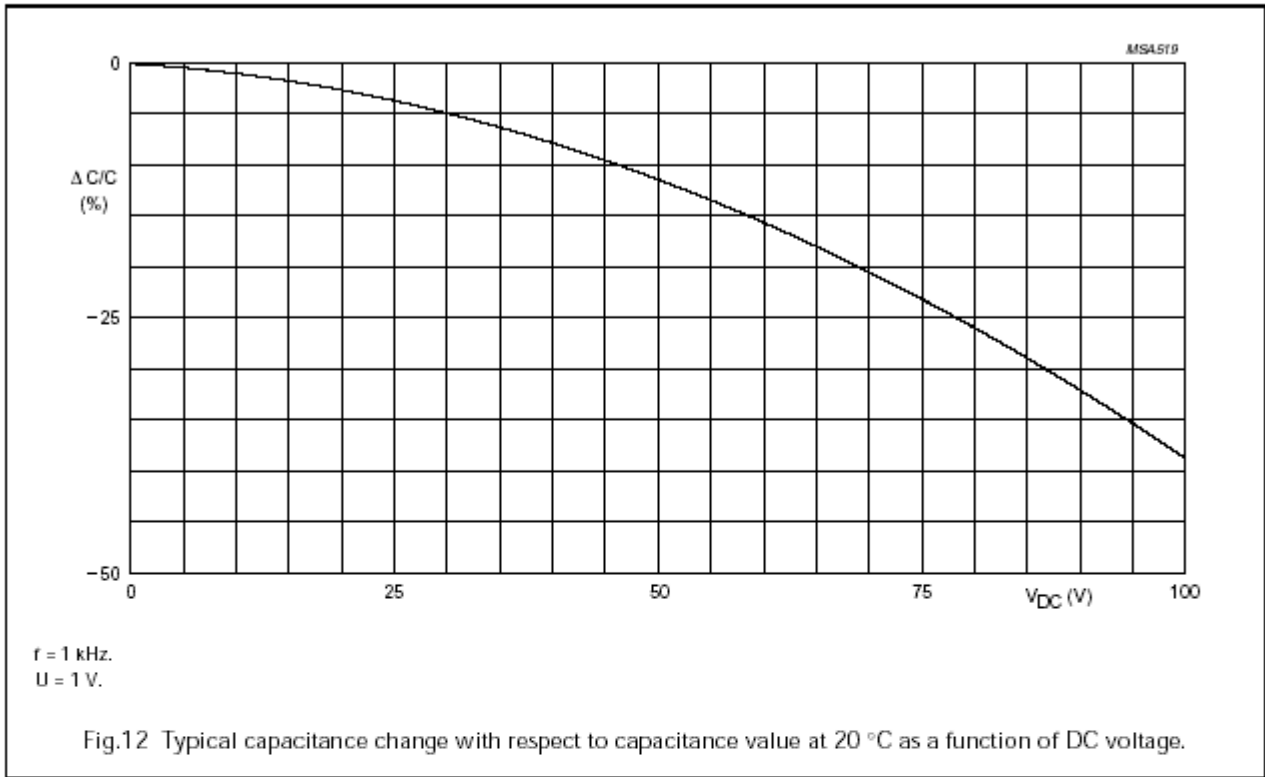

## Miniature ceramic plate capacitors

## Class 2, 63 V and 100 V (DC) (flanged types)

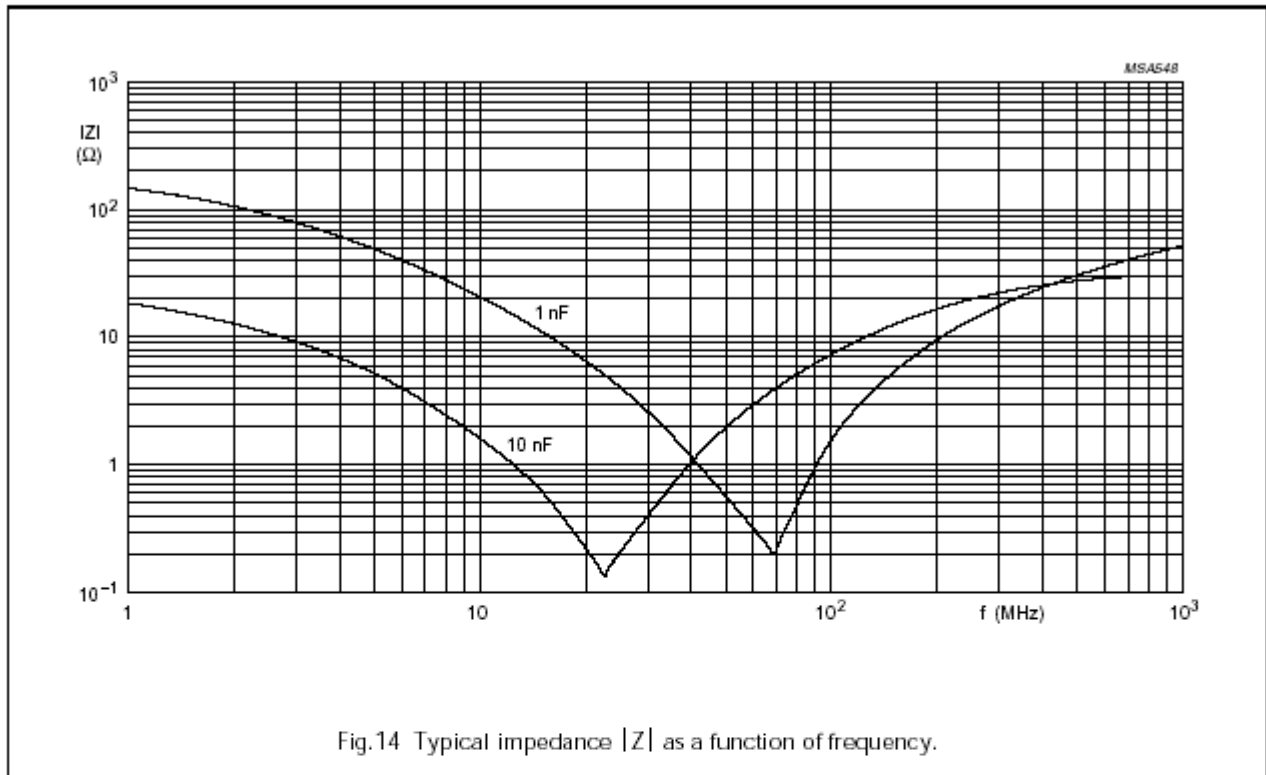

### Capacitors 2222 629 (TC code 2F6)

The capacitors meet the essential requirements of "IEC 60384-9" (2F6), "EIA" (Y5V). Unless stated otherwise all electrical values apply at an ambient temperature of  $20 \pm 1$  °C, an atmospheric pressure of 86 to 106 kPa and a relative humidity of 63 to 67%.

DESCRIPTION	VALUE
Capacitance values measured at 1 kHz, 1 V	1000 to 47000 pF; E3 series (see Table 5)
Tolerance on capacitance, after 1000 hours	-20 to +80%
Dielectric material	K14000
Maximum capacitance change with respect to capacitance value at 20 °C	+20 to -85% (see Figs 15 and 16)
Rated DC voltage at 85 °C	63 V
DC test voltage; duration 1 minute	200 V
DC test voltage of coating; duration 1 minute	200 V
Insulation resistance at 100 V (DC) after 1 minute	$\geq 4000 \text{ M}\Omega$
Tan $\delta$ measured at 1 kHz, 1 V	$\leq 3.5\%$
Category temperature range	-10 to +85 °C
Ageing	typical 5% per time decade
Climatic category (IEC 60068)	10/085/21

**Miniature ceramic plate capacitors**

**Class 2, 63 V and 100 V (DC) (flanged types)**

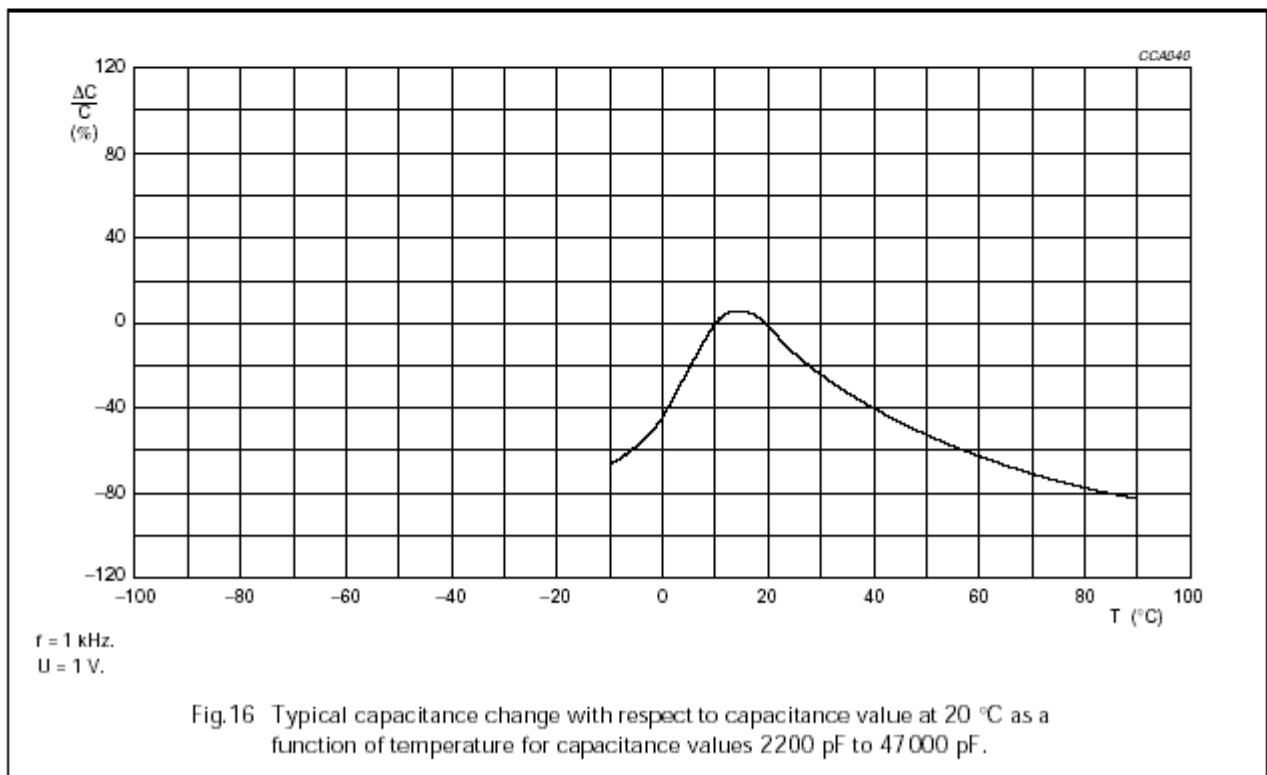
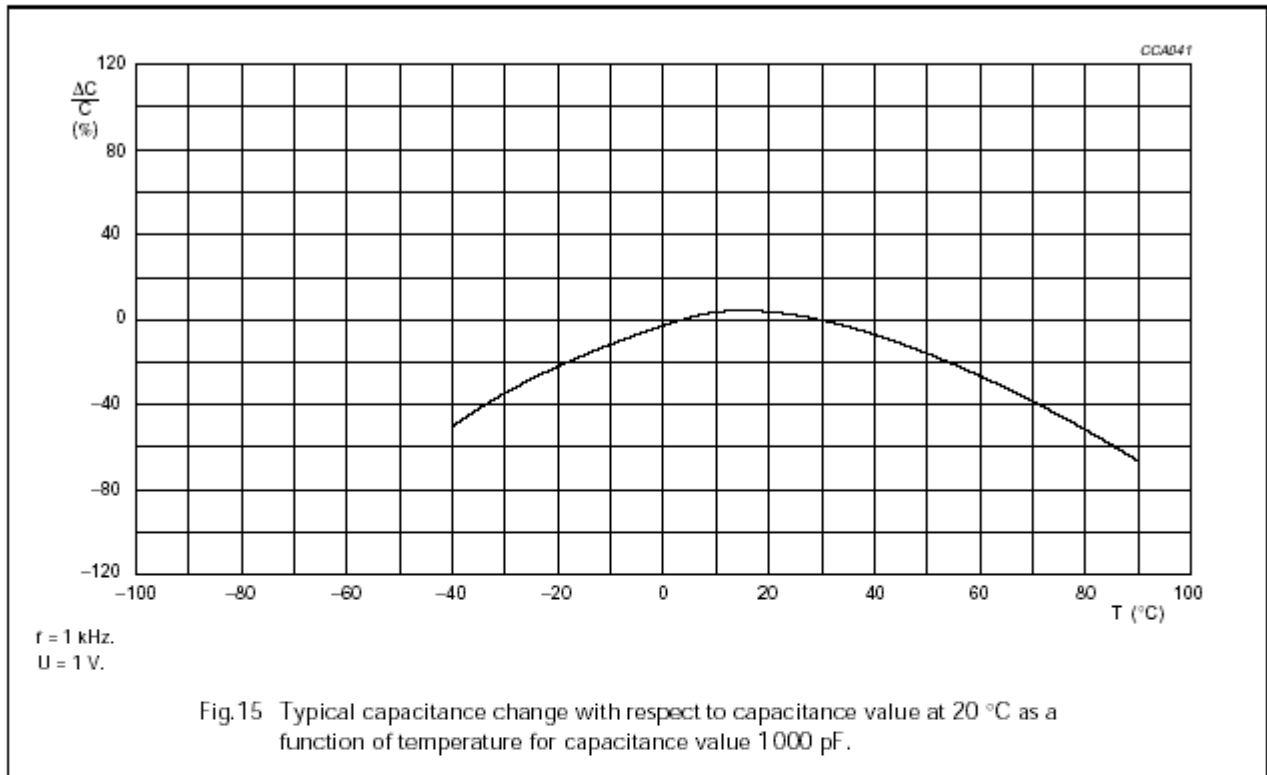

**Miniature ceramic plate capacitors**

**Class 2, 63 V and 100 V (DC) (flanged types)**

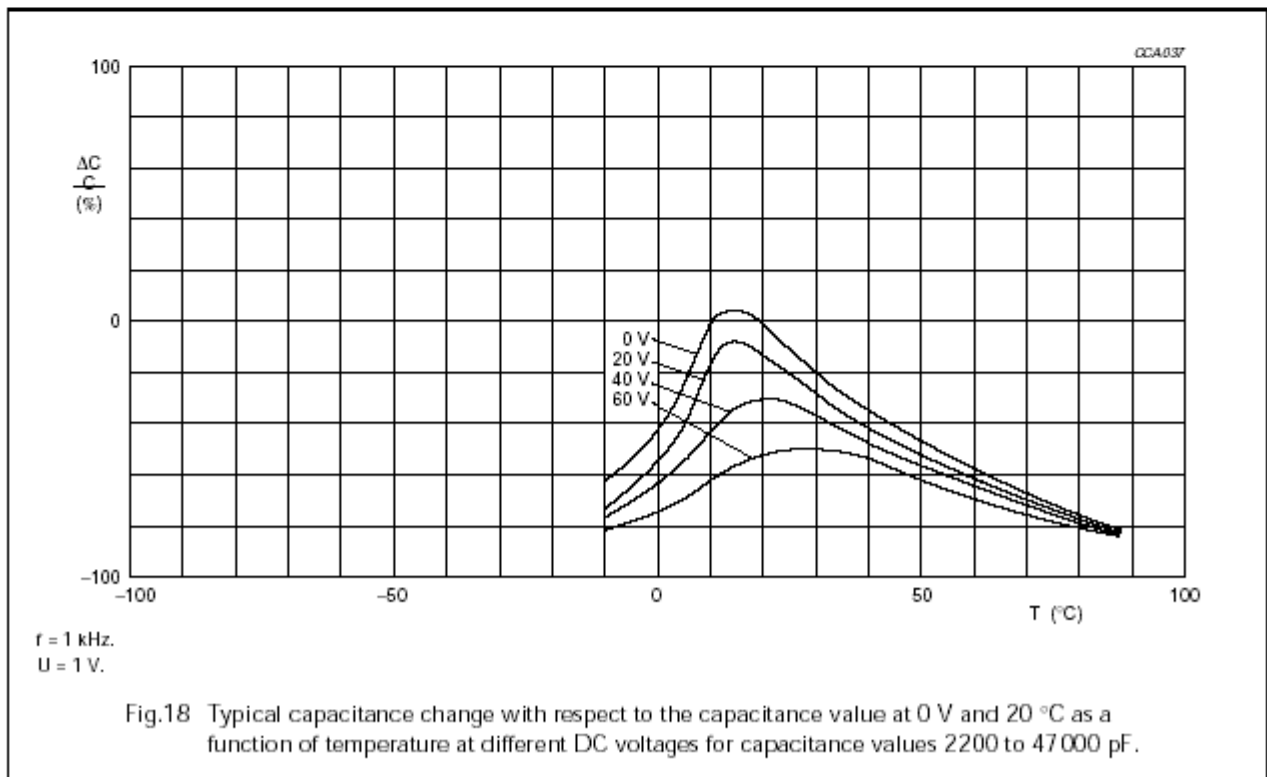
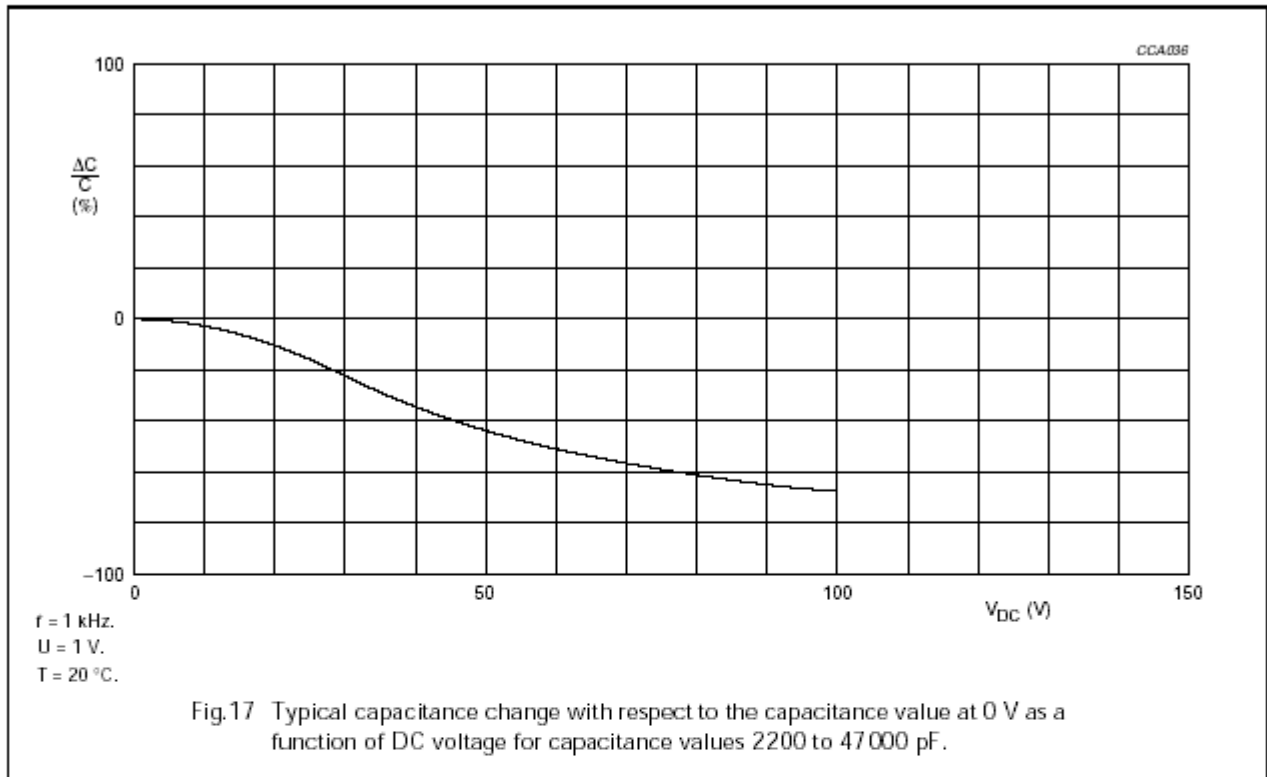

**Miniature ceramic plate capacitors**

**Class 2, 63 V and 100 V (DC) (flanged types)**

