



DM54155/DM74155, DM54156/DM74156

Dual 2-Line to 4-Line Decoders/Demultiplexers

General Description

These TTL circuits feature dual 1-line-to-4-line demultiplexers with individual strobes and common binary-address inputs in a single 16-pin package. When both sections are enabled by the strobes, the common address inputs sequentially select and route associated input data to the appropriate output of each section. The individual strobes permit activating or inhibiting each of the 4-bit sections as desired. Data applied to input C1 is inverted at its outputs and data applied at C2 is true through its outputs. The inverter following the C1 data input permits use as a 3-to-8-line decoder, or 1-to-8-line demultiplexer, without external gating. Input clamping diodes are provided on these circuits to minimize transmission-line effects and simplify system design.

- Individual strobes simplify cascading for decoding or demultiplexing larger words
- Input clamping diodes simplify system design
- Choice of outputs:
 - Totem-pole (155)
 - Open-collector (156)

Absolute Maximum Ratings (Note 1)

Supply Voltage	7V
Input Voltage	5.5V
Output Voltage (for 156)	7V
Storage Temperature Range	-65°C to 150°C

Note 1: The "Absolute Maximum Ratings" are those values beyond which the safety of the device can not be guaranteed. The device should not be operated at these limits. The parametric values defined in the "Electrical Characteristics" table are not guaranteed at the absolute maximum ratings. The "Recommended Operating Conditions" table will define the conditions for actual device operation.

Features

- Applications:
 - Dual 2-to-4-line decoder
 - Dual 1-to-4-line demultiplexer
 - 3-to-8-line decoder
 - 1-to-8-line demultiplexer

Connection Diagram

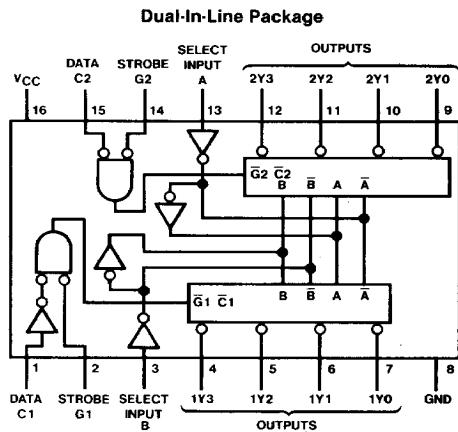

54155 (J) 74155 (N)
54156 (J) 74156 (N)

TL/F/6549-1

Function Tables

2-Line-to-4-Line Decoder or 1-Line-to-4-Line Demultiplexer

Inputs				Outputs			
Select	Strobe	Data					
B	A	G1	C1	1Y0	1Y1	1Y2	1Y3
X	X	H	X	H	H	H	H
L	L	L	H	L	H	H	H
L	H	L	H	H	L	H	H
H	L	L	H	H	H	L	H
H	H	L	H	H	H	H	L
X	X	X	L	H	H	H	H

Inputs				Outputs			
Select	Strobe	Data					
B	A	G2	C2	2Y0	2Y1	2Y2	2Y3
X	X	H	X	H	H	H	H
L	L	L	L	L	H	H	H
L	H	L	L	H	L	H	H
H	L	L	L	H	H	L	H
H	H	L	L	H	H	H	L
X	X	X	H	H	H	H	H

3-Line-to-8-Line Decoder or 1-Line-to-8-Line Demultiplexer

Inputs				Outputs							
C1	Select		Strobe Or Data	(0)	(1)	(2)	(3)	(4)	(5)	(6)	(7)
	B	A		G1	2Y0	2Y1	2Y2	2Y3	1Y0	1Y1	1Y2
X	X	X	H	H	H	H	H	H	H	H	H
L	L	L	L	L	H	H	H	H	H	H	H
L	L	H	L	H	L	H	H	H	H	H	H
L	H	L	L	H	H	L	H	H	H	H	H
L	H	H	L	H	H	H	L	H	H	H	H
H	L	L	L	H	H	H	L	H	H	H	H
H	L	H	L	H	H	H	H	L	H	H	H
H	H	L	L	H	H	H	H	H	L	H	H
H	H	H	L	H	H	H	H	H	H	L	H
X	X	X	H	H	H	H	H	H	H	H	H

IC = inputs C1 and C2 connected together
IG = inputs G1 and G2 connected together
H = high level, L = low level, X = don't care

Recommended Operating Conditions

Sym	Parameter	DM54155			DM74155			Units
		Min	Nom	Max	Min	Nom	Max	
V _{CC}	Supply Voltage	4.5	5	5.5	4.75	5	5.25	V
V _{IH}	High Level Input Voltage	2			2			V
V _{IL}	Low Level Input Voltage			0.8			0.8	V
I _{OH}	High Level Output Current			-0.8			-0.8	mA
I _{OL}	Low Level Output Current			16			16	mA
T _A	Free Air Operating Temperature	-55		125	0		70	°C

'155 Electrical Characteristics

over recommended operating free air temperature (unless otherwise noted)

Sym	Parameter	Conditions	Min	Typ (Note 1)	Max	Units	
V _I	Input Clamp Voltage	V _{CC} = Min, I _I = -12 mA			-1.5	V	
V _{OH}	High Level Output Voltage	V _{CC} = Min, I _{OH} = Max V _{IL} = Max, V _{IH} = Min	2.4			V	
V _{OL}	Low Level Output Voltage	V _{CC} = Min, I _{OL} = Max V _{IH} = Min, V _{IL} = Max			0.4	V	
I _I	Input Current@Max Input Voltage	V _{CC} = Max, V _I = 5.5V			1	mA	
I _{IH}	High Level Input Current	V _{CC} = Max, V _I = 2.4V			40	μA	
I _{IL}	Low Level Input Current	V _{CC} = Max, V _I = 0.4V			-1.6	mA	
I _{OS}	Short Circuit Output Current	V _{CC} = Max (Note 2)	DM54	-20		-55	mA
			DM74	-18		-55	
I _{CC}	Supply Current	V _{CC} = Max (Note 3)	DM54		25	35	mA
			DM74		25	40	

Note 1: All typicals are at V_{CC} = 5V, T_A = 25°C.

Note 2: Not more than one output should be shorted at a time.

Note 3: I_{CC} is measured with the outputs open, A, B, and C1 inputs at 4.5V, and C2, G1, and G2 inputs grounded.

'155 Switching Characteristicsat $V_{CC} = 5V$ and $T_A = 25^\circ C$ (See Section 1 for Test Waveforms and Output Load)

Parameter	From (Input) To (Output)	$R_L = 400\Omega$ $C_L = 15\text{ pF}$			Units
		Min	Typ	Max	
t_{PLH} Propagation Delay Time Low to High Level Output	A, B, C2 G1 or G2 to Y		13	20	ns
t_{PHL} Propagation Delay Time High to Low Level Output	A, B, C2 G1 or G2 to Y		18	27	ns
t_{PLH} Propagation Delay Time Low to High Level Output	A or B to Y		18	27	ns
t_{PHL} Propagation Delay Time High to Low Level Output	A or B to Y		17	26	ns
t_{PLH} Propagation Delay Time Low to High Level Output	C1 to Y		17	24	ns
t_{PHL} Propagation Delay Time High to Low Level Output	C1 to Y		17	26	ns

Recommended Operating Conditions

Sym	Parameter	DM54156			DM74156			Units
		Min	Nom	Max	Min	Nom	Max	
V_{CC}	Supply Voltage	4.5	5	5.5	4.75	5	5.25	V
V_{IH}	High Level Input Voltage	2			2			V
V_{IL}	Low Level Input Voltage			0.8			0.8	V
V_{OH}	High Level Output Voltage			5.5			5.5	V
I_{OL}	Low Level Output Current			16			16	mA
T_A	Free Air Operating Temperature	- 55		125	0		70	$^\circ C$

'156 Electrical Characteristics

over recommended operating free air temperature (unless otherwise noted)

Sym	Parameter	Conditions	Min	Typ (Note 1)	Max	Units
V_I	Input Clamp Voltage	$V_{CC} = \text{Min}, I_I = -12 \text{ mA}$			-1.5	V
I_{CEX}	High Level Output Current	$V_{CC} = \text{Min}, V_O = 5.5V$ $V_{IL} = \text{Max}, V_{IH} = \text{Min}$			250	μA
V_{OL}	Low Level Output Voltage	$V_{CC} = \text{Min}, I_{OL} = \text{Max}$ $V_{IH} = \text{Min}, V_{IL} = \text{Max}$			0.4	V
I_I	Input Current @ Max Input Voltage	$V_{CC} = \text{Max}, V_I = 5.5V$			1	mA
I_{IH}	High Level Input Current	$V_{CC} = \text{Max}, V_I = 2.4V$			40	μA
I_{IL}	Low Level Input Current	$V_{CC} = \text{Max}, V_I = 0.4V$			-1.6	mA
I_{CC}	Supply Current	$V_{CC} = \text{Max}$ (Note 2)	DM54	25	35	mA
			DM74	25	40	

'156 Switching Characteristicsat $V_{CC} = 5V$ and $T_A = 25^\circ\text{C}$ (See Section 1 for Test Waveforms and Output Load)

Parameter	From (Input) To (Output)	$R_L = 400\Omega$ $C_L = 15 \text{ pF}$			Units
		Min	Typ	Max	
t_{PLH} Propagation Delay Time Low to High Level Output	A, B, C2 G1 or G2 to Y		15	23	ns
t_{PHL} Propagation Delay Time High to Low Level Output	A, B, C2 G1 or G2 to Y		19	30	ns
t_{PLH} Propagation Delay Time Low to High Level Output	A or B to Y		21	32	ns
t_{PHL} Propagation Delay Time High to Low Level Output	A or B to Y		18	27	ns
t_{PLH} Propagation Delay Time Low to High Level Output	C1 to Y		19	27	ns
t_{PHL} Propagation Delay Time High to Low Level Output	C1 to Y		18	27	ns

Note 1: All typicals are at $V_{CC} = 5V$, $T_A = 25^\circ\text{C}$.**Note 2:** I_{CC} is measured with all outputs open, A, B, and C1 inputs at 4.5V, and C2, G1, and G2 inputs grounded.

Logic Diagram

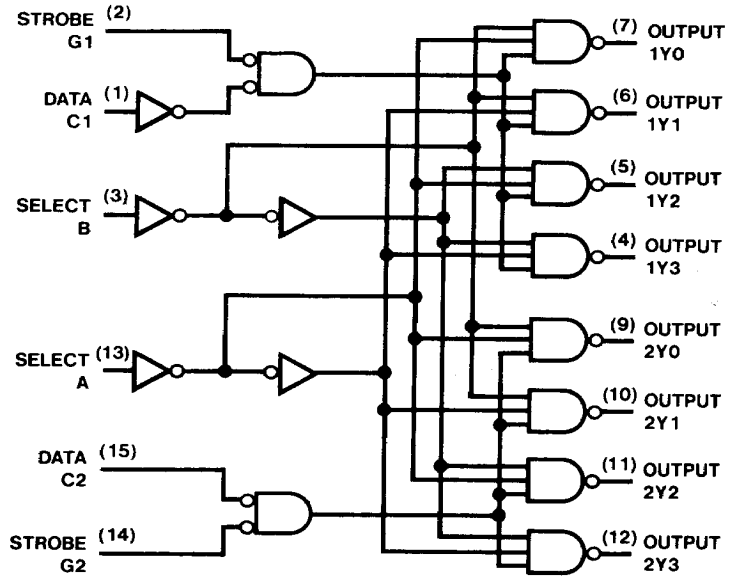

TL/F/6549-2