

## High Current 100 kHz to 6000 MHz



JEBT

MODEL NO.	FREQ. RANGE (MHz) $f_l$ - $f_u$	INSERTION LOSS* (dB)						ISOLATION* (dB) (RF-DC, RF&DC-DC)						CASE STYLE Note B	CONNECTION	PRICE \$ Qty. (1-9)
		L		M		U		L		M		U				
		Typ.	Max.	Typ.	Max.	Typ.	Max.	Typ.	Min.	Typ.	Min.	Typ.	Min.			
JEBT-4R2G	10-4200	0.15	0.6	0.6	1.2	0.6	1.6	32	20	40	20	40	20	BL301	hr	39.95
JEBT-6G	10-6000	0.15	0.6	0.7	1.4	1.3	2.9	32	20	40	20	40	17	BL301	hr	59.95
JEBT-4R2GW	0.1-4200	0.15	0.8	0.6	1.2	0.6	1.6	25	15	40	20	40	20	BL301	hr	59.95
JEBT-6GW	0.1-6000	0.15	0.8	0.7	1.4	1.3	2.9	25	15	40	20	30	17	BL301	hr	69.95

L = low range [ $f_l$  to  $10f_l$ ]    M = mid range [ $10f_l$  to  $f_u/2$ ]    U = upper range [ $f_u/2$  to  $f_u$ ]

### features

- wide band coverage 0.1 to 6000 MHz
- low insertion loss 0.6 dB typ.
- good isolation 40dB typ.
- small size (JEBT) 1.26 X 0.94 X 0.39 inch
- feedthrough version (FT) available for coaxial models

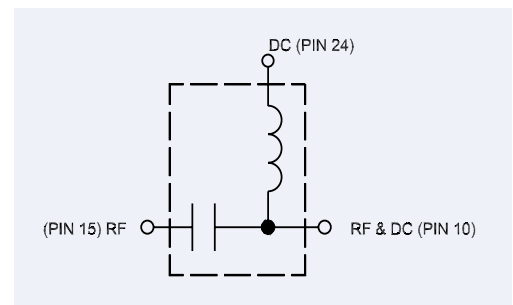

### NOTES:

- Non-hermetic
- \* Insertion loss and isolation are guaranteed up to 20 dBm-RF power and 200 mA DC current for PBTC, JEBT, and ZFBT Series; for ZNBT, up to 30 dBm RF power and 500mA DC current.
- \*\* VSWR measured with open and short at DC port.
- ❖ Insertion loss 1 dB Max. and isolation 7 dB Min. 0.1 to 0.3 MHz.
- ▼ Connectors: SMA-F at "RF", and SMA-M at "RF & DC" port.  
For DC port, ZFBT available with SMA-F and for ZFBT-FT available with feedthrough terminal. For ZNBT-60-1W, N-M at "RF", N-F at "RF+DC", BNC-F at DC.
- A. General Quality Control Procedures, Environmental Specifications, Hi-Rel and MIL description are given in General Information (Section 0).
- B. Case mounted options, case finishes are given in section 0, see "Case styles & Outline Drawings".
- C. Prices and specifications subject to change without notice.
- 1. Absolute maximum power, voltage and current ratings:
  - 1a. max. input current: 500 mA
  - 1b. max. RF power: 30 dBm
  - 1c. max. voltage at DC port: 30V; JEBT series, 25V.
- 2. DC resistance from DC to RF & DC port: 4.5 ohm typical.

## Plug-In & Coaxial

### WIDEBAND 0.1 to 6000 MHz

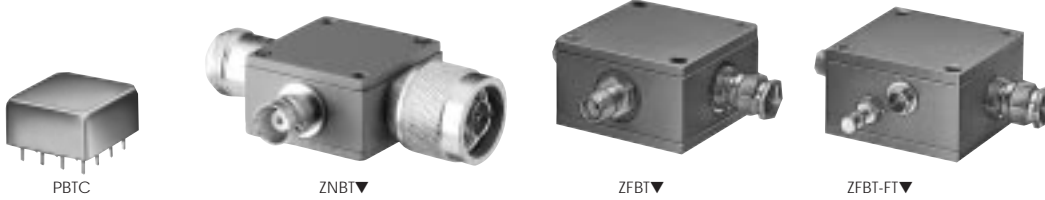

MODEL NO.	FREQ. RANGE (MHz) $f_l$ - $f_u$	INSERTION LOSS* (dB)						ISOLATION* (dB) (RF port to DC port) (RF&DC port to DC port)						VSWR** (:1)				CASE STYLE ▼ Note B	CONNECTION	PRICE \$ Qty. (1-9)		
		L		M		U		L		M		U		L		M					U	
		Typ.	Max.	Typ.	Max.	Typ.	Max.	Typ.	Min.	Typ.	Min.	Typ.	Min.	Typ.	Max.	Typ.	Max.	Typ.	Max.			
PBTC-1G	10-1000	0.15	0.7	0.3	0.7	0.3	1.0	27	20	33	20	30	20	1.06	1.2	1.06	1.2	1.1	1.38	CO7	hh	25.95
PBTC-3G	10-3000	0.15	0.7	0.3	1.5	1.0	2.5	27	20	30	20	35	20	1.06	1.2	1.13	1.66	1.6	1.7	CO7	hh	35.95
❖ PBTC-1GW	0.1-1000	0.15	0.8	0.3	0.7	0.3	1.0	25	15	33	20	30	20	1.06	1.6	1.06	1.2	1.1	1.38	CO7	hh	35.95
❖ PBTC-3GW	0.1-3000	0.15	0.8	0.3	1.5	1.0	2.5	25	15	30	20	35	20	1.06	1.6	1.13	1.66	1.6	1.7	CO7	hh	46.95
<b>NEW</b> ZNBT-60-1W	2.5-6000	0.2	0.9	0.6	2.0	1.6	2.2	75	45	45	25	35	20	1.1	1.5	1.1	1.3	1.35	1.6	K558	gf	82.95
ZFBT-4R2G	10-4200	0.15	0.6	0.6	1.2	0.6	1.6	32	20	40	20	50	20	1.06	1.2	1.13	1.3	1.13	1.3	K18	gf	59.95
ZFBT-4R2G-FT	10-4200	0.15	0.6	0.6	1.2	0.6	1.6							1.06	1.2	1.13	1.3	1.13	1.3	Y460	hf	59.95
ZFBT-6G	10-6000	0.15	0.6	0.6	1.4	1.0	2.2	32	20	40	20	30	17	1.06	1.2	1.13	1.3	1.13	1.5	K18	gf	79.95
ZFBT-6G-FT	10-6000	0.15	0.6	0.6	1.4	1.0	2.2							1.06	1.2	1.13	1.3	1.13	1.5	Y460	hf	79.95
❖ ZFBT-4R2GW	0.1-4200	0.15	0.8	0.6	1.2	0.6	1.6	25	15	40	20	50	20	1.06	1.6	1.13	1.3	1.13	1.3	K18	gf	79.95
❖ ZFBT-4R2GW-FT	0.1-4200	0.15	0.8	0.6	1.2	0.6	1.6							1.06	1.6	1.13	1.3	1.13	1.3	Y460	hf	79.95
❖ ZFBT-6GW	0.1-6000	0.15	0.8	0.6	1.4	1.0	2.2	25	15	40	20	30	17	1.06	1.6	1.13	1.3	1.13	1.5	K18	gf	89.95
❖ ZFBT-6GW-FT	0.1-6000	0.15	0.8	0.6	1.4	1.0	2.2							1.06	1.6	1.13	1.3	1.13	1.5	Y460	hf	89.95

L = low range [ $f_l$  to  $10 f_l$ ]      M = mid range [ $10 f_l$  to  $f_u/2$ ]      U = upper range [ $f_u/2$  to  $f_u$ ]

#### applications

- biasing amplifiers
- biasing of laser diodes
- DC return
- DC blocking
- good for digital & analog applications

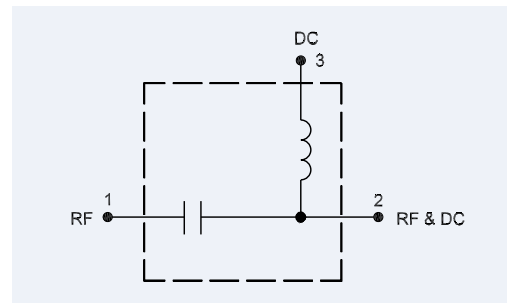

#### pin & coaxial connections

PORT	gf	hf	hh	hr
RF	1	in	9	15
RF & DC	2	out	12	10
DC	3	+15	3	24
GND	—	—	all other pins	all other pins

#### NSN GUIDE

MCL NO. NSN  
ZFBT-4R2G 5895-01-481-4754



The Design Engineers Search Engine  
Provides Actual Data Instantly  
At: <http://www.minicircuits.com>

In Stock... Immediate Delivery  
For Custom Versions Of Standard Models  
Consult Our Applications Dept.

