

The documentation and process conversion measures necessary to comply with this revision shall be completed by 12 December 2013.

INCH-POUND

MIL-PRF-19500/500E  
w/AMENDMENT 1  
12 September 2013  
SUPERSEDING  
MIL-PRF-19500/500E  
24 March 2009

## PERFORMANCE SPECIFICATION SHEET

SEMICONDUCTOR DEVICE, DIODE, SILICON, UNIPOLAR TRANSIENT VOLTAGE SUPPRESSOR, TYPES 1N5555 THROUGH 1N5558, 1N5907, 1N5629A THROUGH 1N5665A, JAN, JANTX, AND JANTXV

This specification is approved for use by all Departments and Agencies of the Department of Defense.

The requirements for acquiring the product described herein shall consist of this specification sheet and MIL-PRF-19500.

### 1. SCOPE

1.1 Scope. This specification covers the performance requirements for 1,500 watt, silicon, transient voltage suppressor diodes. Three levels of product assurance are provided for each device type as specified in MIL-PRF-19500.

1.2 Physical dimensions. See [figure 1](#) (DO-13).

1.3 Maximum ratings. Maximum ratings are as shown in maximum test ratings (see [3.6](#) herein) and as follows:

$P_{PP} = 1500 \text{ W}$  (see figures 2 and 3) at  $t_p = 1.0 \text{ ms}$ .

$P_{M(AV)} = 1.0 \text{ W}$  (derate at  $6.67 \text{ mW}/^\circ\text{C}$  above  $T_A = +25^\circ\text{C}$ ) (see [6.5](#) herein).

$I_{FSM} = 200 \text{ A (pk)}$  at  $t_p = 8.3 \text{ ms}$  ( $T_A = +25^\circ\text{C}$ ).

$-55^\circ\text{C} \leq T_J \leq +175^\circ\text{C}$  (ambient),  $-55^\circ\text{C} \leq T_{STG} \leq +175^\circ\text{C}$  (ambient).

1.4 Primary electrical characteristics at  $T_A = +25^\circ\text{C}$ . Primary ratings are as shown in maximum test ratings (see [3.6](#)).

\* Comments, suggestions, or questions on this document should be addressed to DLA Land and Maritime, ATTN: VAC, P.O. Box 3990, Columbus, OH 43218-3990, or emailed to [Semiconductor@dla.mil](mailto:Semiconductor@dla.mil). Since contact information can change, you may want to verify the currency of this address information using the ASSIST Online database at <https://assist.dla.mil>.

AMSC N/A

FSC 5961

MIL-PRF-19500/500E  
w/AMENDMENT 1

2. APPLICABLE DOCUMENTS

2.1 General. The documents listed in this section are specified in sections 3, 4, or 5 of this specification. This section does not include documents cited in other sections of this specification or recommended for additional information or as examples. While every effort has been made to ensure the completeness of this list, document users are cautioned that they must meet all specified requirements of documents cited in sections 3, 4, or 5 of this specification, whether or not they are listed.

2.2 Government documents.

2.2.1 Specifications, standards, and handbooks. The following specifications, standards, and handbooks form a part of this document to the extent specified herein. Unless otherwise specified, the issues of these documents are those cited in the solicitation or contract.

DEPARTMENT OF DEFENSE SPECIFICATIONS

MIL-PRF-19500 - Semiconductor Devices, General Specification for.

DEPARTMENT OF DEFENSE STANDARDS

MIL-STD-750 - Test Methods for Semiconductor Devices.

\* (Copies of these documents are available online at <http://quicksearch.dla.mil/> or <https://assist.dla.mil/> or from the Standardization Document Order Desk, 700 Robbins Avenue, Building 4D, Philadelphia, PA 19111-5094.)

2.3 Order of precedence. Unless otherwise noted herein or in the contract, in the event of a conflict between the text of this document and the references cited herein, the text of this document takes precedence. Nothing in this document, however, supersedes applicable laws and regulations unless a specific exemption has been obtained.

MIL-PRF-19500/500E  
w/AMENDMENT 1

3. REQUIREMENTS

3.1 General. The individual item requirements shall be as specified in MIL-PRF-19500 and as modified herein.

3.2 Qualification. Devices furnished under this specification shall be products that are manufactured by a manufacturer authorized by the qualifying activity for listing on the applicable qualified manufacturer's list (QML) before contract award (see 4.2 and 6.3).

3.3 Abbreviations, symbols, and definitions. Abbreviations, symbols, and definitions used herein shall be as specified in MIL-PRF-19500 and as follows:  $I_{(BR)}$  - reverse breakdown current at a specified condition.

3.4 Interface and physical dimensions. The interface and physical dimensions shall be as specified in MIL-PRF-19500, and on [figure 1](#) (DO-13) herein.

3.4.1 Metallurgically bonded construction. Metallurgically bonded construction is required. The bonding flow shall have flow points above 260°C.

3.4.2 Lead finish. Lead finish shall be solderable in accordance with MIL-PRF-19500, MIL-STD-750, and herein. Where a choice of lead finish is desired, it shall be specified in the acquisition document (see 6.2).

3.5 Marking. Devices shall be marked in accordance with MIL-PRF-19500.

3.6 Electrical performance characteristics. Unless otherwise specified, the electrical performance characteristics are as specified in 1.3, 1.4, and [table I](#). Maximum ratings shall be in accordance with columns 6 through 8 of [table II](#). Primary electrical characteristics are shown in columns 4 and 5 of [table II](#) herein.

3.7 Electrical test requirements. The electrical test requirements shall be the subgroups specified in [table I](#), subgroup 2.

3.8 Workmanship. Semiconductor devices shall be processed in such a manner as to be uniform in quality and shall be free from other defects that will affect life, serviceability, or appearance.

MIL-PRF-19500/500E  
w/AMENDMENT 1

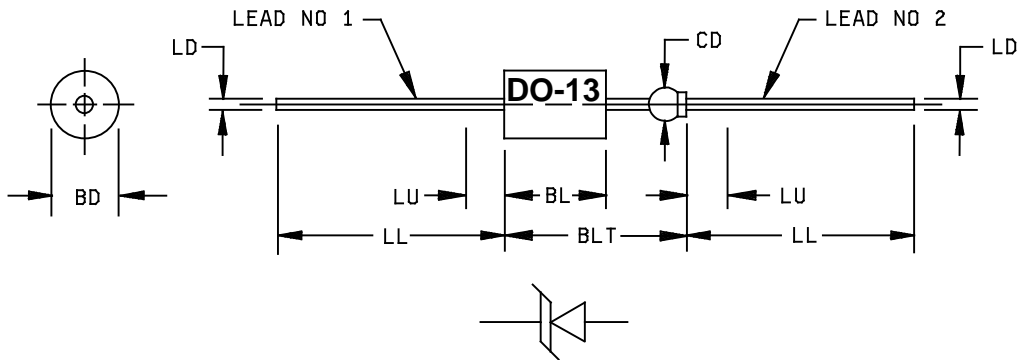

Symbol	Dimensions				Notes
	Inches		Millimeters		
	Min	Max	Min	Max	
BD	.215	.235	5.46	5.97	
BL	.293	.357	7.44	9.07	3
BLT		.570		14.48	
CD	.045	.100	1.14	2.54	5
LD	.025	.035	0.64	0.89	
LL	1.000	1.625	25.40	41.28	4
LU		.188		4.78	4

NOTES:

1. Dimensions are in inches.
2. Millimeters are given for general information only.
3. The major diameter is essentially constant along its length.
4. Within this zone, diameter may vary to allow for lead finishes and irregularities.
5. Dimension to allow for pinch or seal deformation anywhere along tubulation.
6. Lead 1 (cathode) shall be electrically connected to the case.
7. In accordance with ASME Y14.5M, diameters are equivalent to  $\Phi x$  symbology.

FIGURE 1. Physical dimensions (DO-13).

MIL-PRF-19500/500E  
w/AMENDMENT 1

4. VERIFICATION

4.1 Classification of inspections. The inspection requirements specified herein are classified as follows:

- a. Qualification inspection (see 4.2).
- b. Screening (see 4.3).
- c. Conformance inspection (see 4.4, and tables I, II, III, and IV).

4.1.1 Sampling and inspection. Sampling and inspection shall be in accordance with MIL-PRF-19500, and as specified herein except, lot accumulation shall be 6-months in lieu of 6-weeks.

4.2 Qualification inspection. Qualification inspection shall be in accordance with MIL-PRF-19500 and as specified herein.

4.2.1 Group E qualification. Group E inspection shall be performed for qualification or re-qualification only. In case qualification was awarded to a prior revision of the specification sheet that did not request the performance of [table IV](#) tests, the tests specified in [table IV](#) herein that were not performed in the prior revision shall be performed on the first inspection lot of this revision to maintain qualification.

4.3 Screening (JANTX and JANTXV levels only). Screening shall be in accordance with table E-IV of MIL-PRF-19500, and as specified herein. The following measurements shall be made in accordance with [table I](#) herein. Devices that exceed the limits of [table I](#) herein shall not be acceptable.

Screen (see table E-IV of MIL-PRF-19500)	Measurement
	JANTX and JANTXV levels
3a	T(high) = +175°C
9, 10, 11	Not applicable
12	See <a href="#">4.3.1</a>
13	Interim electrical, delta, and <a href="#">table I</a> , subgroups 2 and 3, electrical parameters not applicable for this screen (performed in screen 12).
14	Required
15	For JANTXV devices only – 100 percent inspection will be in accordance with manufacturer's internal failure criteria.

MIL-PRF-19500/500E  
w/AMENDMENT 1

4.3.1 Power burn-in (HTRB) and steady-state operation life test conditions. The test conditions and order of events shall be as follows:

- a. Pulse in accordance with 4.5.2.a herein, 20 times (screening and group B) and 100 times (group C) at  $T_A = +25^\circ\text{C}$ .
- b. Read  $I_D$  and  $V_{(BR)}$  at  $T_A = +25^\circ\text{C}$ , remove defective devices and record the number of failures.
- c. Apply the working peak reverse voltage ( $V_{WM}$ ) (column 4 of table II herein) at  $T_A = +125^\circ\text{C}$  as follows:
  - (1) For 96 hours (JANTX and JANTXV).
  - (2) For 340 hours (JANTX and JANTXV) for group B steady-state operation life test.
  - (3) For 1,000 hours for group C steady-state operation life test.
- d. Read  $I_D$  and  $V_{(BR)}$  at  $T_A = +25^\circ\text{C}$ . Devices with  $\Delta I_D > 50$  percent (100 percent for steady-state operation life) of the initial reading or  $1 \mu\text{A}$  dc, whichever is greater, or  $\Delta V_{(BR)} > \pm 2$  percent ( $\pm 5$  percent for steady-state operation life) of initial value shall be considered defective. Remove defective devices and record the number of failures.

4.4 Conformance inspection. Conformance inspection shall be in accordance with MIL-PRF-19500.

4.4.1 Group A inspection. Group A inspection shall be conducted in accordance with MIL-PRF-19500 and table I herein. End-point electrical measurements shall be in accordance with table I, subgroup 2 herein.

4.4.2 Group B inspection. Group B inspection shall be conducted in accordance with the conditions specified for subgroup testing in table E-VIb (JAN, JANTX, and JANTXV) of MIL-PRF-19500. Electrical measurements (end-points) and delta requirements shall be in accordance with the applicable steps of table III herein.

4.4.2.1 Group B inspection, table E-VIb of MIL-PRF-19500.

<u>Subgroup</u>	<u>Method</u>	<u>Conditions</u>
B2	1051	$-55^\circ\text{C}$ to $+175^\circ\text{C}$ .
B2	4066	10 pulses, see 4.5.2 herein.
B3	1027	See 4.5.1 and 4.5.3.
B5		Not applicable.

MIL-PRF-19500/500E  
w/AMENDMENT 1

4.4.3 Group C inspection. Group C inspection shall be conducted in accordance with the conditions specified for subgroup testing in table E-VII of MIL-PRF-19500. Electrical measurements (end-points) and delta requirements shall be in accordance with the applicable steps of [table III](#) herein.

\* 4.4.3.1 Group C inspection, table E-VII of MIL-PRF-19500.

<u>Subgroup</u>	<u>Method</u>	<u>Conditions</u>
* C2	2036	Lead tension: Test condition A; weight = 10 pounds (4.54 kg); t = 15 ±3 s. Lead fatigue: Test condition E; weight = 8 ounces (226.7 g).
C5		Not applicable
C6	1026	See 4.5.1 and 4.5.2 herein.
C7	1018	n = 3, c = 0 or n = 5, c = 1.
C8		Condition for temperature coefficient of breakdown voltage is as follows: $I_{BR} =$ column 3 of <a href="#">table II</a> herein, $T_1 = +25^{\circ}\text{C} \pm 3^{\circ}\text{C}$ , $T_2 = T_1 + 100^{\circ}\text{C}$ ; n = 22, c = 0.
C9		Condition for maximum peak pulse current is as follows: See 4.5.2.b herein, (20 μs pulse only) 10 pulses; n = 22, c = 0.

4.4.4 Group E inspection. Group E inspection shall be conducted in accordance with the conditions specified for subgroup testing in appendix E, table E-IX of MIL-PRF-19500 and as specified herein. Electrical measurements (end-points) shall be in accordance with [table I](#), subgroup 2 herein.

4.5 Methods of inspection. Methods of inspection shall be as specified in the appropriate tables as follows.

4.5.1 Group C steady-state operation life test (alternate procedure). When the group B, 340-hour life test is continued on test to 1,000 hours to satisfy the group C life test requirements, the test shall be performed as given in [4.3.1](#) herein with the following exception: Step [4.3.1.d](#) shall be repeated at the end of the 1,000 hours.

\* 4.5.2 Maximum peak pulse current ( $I_{PP}$ ). The peak pulse currents specified in column 7 of [table II](#) herein shall be applied while simultaneously maintaining a bias voltage of not less than the applicable voltage specified in column 4 of [table II](#), in the same polarity as the peak pulse current. The clamping voltage ( $V_c$ ) shall be as specified in [4.5.3](#). The peak pulse current shall be applied with a current vs time waveform as follows (1 pulse per minute maximum):

- Pulse current shall reach 100 percent of  $I_{PP}$  at  $t \leq 10 \mu\text{s}$  and decay to 50 percent of  $I_{PP}$  at  $t \geq 1 \text{ ms}$  for  $t_p = 1 \text{ ms}$  (see [figure 4](#)).
- Pulse current shall reach 100 percent of  $I_{PP}$  at  $t \leq 8 \mu\text{s}$  and decay to 50 percent of  $I_{PP}$  at  $t \geq 20 \mu\text{s}$  for  $t_p = 20 \mu\text{s}$  (see [figure 5](#)).

4.5.3 Clamping voltage. The peak pulse clamping voltage shall be measured across the diode in a 1 ms time interval. The response detector shall demonstrate equipment accuracy of ±3 percent. The peak clamping voltage as specified in column 6 of [table II](#) shall be applicable to the 1 ms pulse of [4.5.2.a](#) only.

MIL-PRF-19500/500E  
w/AMENDMENT 1

TABLE I. Group A inspection.

Inspection <u>1/</u>	MIL-STD-750		Symbol	Limits <u>2/</u>		Unit
	Method	Conditions		Min	Max	
<u>Subgroup 1</u>						
Visual and mechanical examination	2071					
Radiography	2076	For JANTX devices only. Inspection will be in accordance with manufacturer's internal failure criteria, c = 45, n = 0				
<u>Subgroup 2</u>						
Standby current	4016	DC method, $V_R = V_{WM}$ (column 4 of <a href="#">table II</a> )	$I_D$		Column 5	$\mu\text{A dc}$
Breakdown voltage	4022	$t_p \leq 300$ ms, duty cycle $\leq 2$ percent, $I_{BR} =$ column 3 of <a href="#">table II</a>	$V_{BR}$	Column 2	Column 2	V dc
<u>Subgroup 3</u>						
Low temperature operation:		$T_A = -55^\circ\text{C}$				
Minimum breakdown voltage	4022	$t_p \leq 300$ ms, duty cycle $\leq 2$ percent, $I_{BR} =$ column 3 of <a href="#">table II</a>	$V_{BR}$	Column 10		V dc
High temperature operation:		$T_A = 125^\circ\text{C}$				
Reverse current leakage	4016	DC method, $V_R = V_{WM}$ (column 4 of <a href="#">table II</a> )	$I_{D2}$		Column 9	$\mu\text{A dc}$
<u>Subgroup 4</u>						
Clamping voltage maximum		$t_p = 1.0$ ms (see <a href="#">4.5.2.a</a> ), $I_{PP} =$ column 7 of <a href="#">table II</a> , (pulsed) (see <a href="#">4.5.3</a> )	$V_C$		Column 6	V (pk)
Forward voltage	4011	$I_{FM} = 100$ A (pk); $t_p = 8.3$ ms (max), duty cycle = 4 pulses per minute (max)	$V_{FM}$		3.5	V (pk)
<u>Subgroup 5</u>						
Not applicable						

See footnotes at end of table.



MIL-PRF-19500/500E  
w/AMENDMENT 1

TABLE I. Group A inspection - Continued.

Inspection <u>1/</u>	MIL-STD-750		Symbol	Limits <u>2/</u>		Unit
	Method	Conditions		Min	Max	
<u>Subgroup 6</u> Forward surge current	4066	I <sub>FSM</sub> = 200 A (pk), one pulse, half sine wave (8.3 ms), I <sub>F</sub> = 0; V <sub>WM</sub> = 0; T <sub>A</sub> = 25°C  See <a href="#">table III</a> , steps 1 and 2				
End-point electrical measurements						
<u>Subgroup 7</u> Not applicable						

1/ For sampling plan, see MIL-PRF-19500.

2/ Column references are to [table II](#).

TABLE II. Characteristics and ratings.

Col 1	Col 2		Col 3	Col 4	Col 5	Col 6	Col 7		Col 8	Col 9	Col 10
Type	Breakdown voltage		Test current	Working peak reverse voltage	Maximum standby current	Maximum clamping voltage	Maximum peak pulse current I <sub>PP</sub>		Maximum temperature Coefficient of V <sub>BR</sub> αV <sub>BR</sub>	Maximum standby current I <sub>D</sub> T <sub>A</sub> = +125°C	Minimum Breakdown voltage at I <sub>BR</sub> T <sub>A</sub> = -55°C
	V <sub>BR</sub> at I <sub>BR</sub>		I <sub>BR</sub>	V <sub>WM</sub>	I <sub>D</sub>	V <sub>C</sub> at I <sub>PP</sub>	t <sub>p</sub> = 20 μs t <sub>r</sub> = 8 μs	t <sub>p</sub> = 1 ms t <sub>r</sub> = 10 μs			
	V dc Min	V dc Max	mA dc	V (pk)	μA dc	V (pk)	A (pk)	A (pk)	%/°C	μA dc	V dc
1N5907	6.00	6.75	1	5.00	300	10.0	1,000	150.0	.057	1,500	5.63
1N5629A	6.45	7.14	10	5.80	1,000	10.5	810	143.0	.057	4,000	6.05
1N5630A	7.13	7.88	10	6.40	500	11.3	750	132.0	.061	2,000	6.66
1N5631A	7.79	8.61	10	7.02	200	12.1	700	124.0	.065	1,000	7.24
1N5632A	8.65	9.55	1	7.78	50	13.4	630	112.0	.068	400	8.01
1N5633A	9.50	10.50	1	8.55	10	14.5	585	103.5	.073	200	8.75
1N5634A	10.50	11.60	1	9.40	5	15.6	545	96.0	.075	200	9.65
1N5635A	11.40	12.60	1	10.20	5	16.7	510	90.0	.078	200	10.40
1N5636A	12.40	13.70	1	11.10	5	18.2	465	82.0	.081	200	11.30
1N5637A	14.30	15.80	1	12.80	5	21.2	400	71.0	.084	200	13.00
1N5638A	15.20	16.80	1	13.60	5	22.5	375	67.0	.086	200	13.70
1N5639A	17.10	18.90	1	15.30	5	25.2	335	59.5	.088	200	15.40
1N5640A	19.00	21.00	1	17.10	5	27.7	305	54.0	.090	200	17.10
1N5641A	20.90	23.10	1	18.80	5	30.6	275	49.0	.092	200	18.80
1N5642A	22.80	25.20	1	20.50	5	33.2	255	45.0	.094	200	20.50
1N5643A	25.70	28.40	1	23.10	5	37.5	225	40.0	.096	200	23.00
1N5644A	28.50	31.50	1	25.60	5	41.4	205	36.0	.097	200	23.50
1N5645A	31.40	34.70	1	28.20	5	45.7	185	33.0	.098	200	28.00
1N5555	33.00		1	30.50	5	47.5	193	32.0	.093	200	30.20
1N5646A	34.20	37.80	1	30.80	5	49.9	170	30.0	.099	200	30.50

10

TABLE II. Characteristics and ratings - Continued.

Col 1	Col 2		Col 3	Col 4	Col 5	Col 6	Col 7		Col 8	Col 9	Col 10
Type	Breakdown Voltage		Test current	Working peak reverse voltage	Maximum standby current	Maximum clamping voltage	Maximum peak pulse current I <sub>PP</sub>		Maximum temperature coefficient of V <sub>BR</sub> αV <sub>BR</sub>	Maximum standby current I <sub>D</sub> T <sub>A</sub> = +125°C	Minimum breakdown voltage at I <sub>BR</sub> T <sub>A</sub> = -55°C
	V <sub>BR</sub> at I <sub>BR</sub>		I <sub>BR</sub>	V <sub>WM</sub>	I <sub>D</sub>	V <sub>C</sub> at I <sub>PP</sub>	t <sub>p</sub> = 20 μs t <sub>r</sub> = 8 μs	t <sub>p</sub> = 1 ms t <sub>r</sub> = 10 μs			
	V dc Min	V dc Max	mA dc	V (pk)	μA dc	V (pk)	A (pk)	A (pk)	%/°C	μA dc	V dc
1N5647A	37.10	41.00	1	33.30	5	53.9	155	28.0	.100	200	33.10
1N5648A	40.90	45.20	1	36.80	5	59.3	145	25.3	.101	200	36.40
1N5556	43.70		1	40.30	5	63.5	136	24.0	.094	200	40.00
1N5649A	44.70	49.40	1	40.20	5	64.8	130	23.2	.101	200	39.80
1N5650A	48.50	53.60	1	43.60	5	70.1	120	21.4	.102	200	43.10
1N5651A	53.20	58.80	1	47.80	5	77.0	110	19.5	.103	200	47.30
1N5557	54.00		1	49.00	5	78.5	116	19.0	.096	200	48.50
1N5652A	58.90	65.10	1	53.00	5	85.0	100	17.7	.104	200	52.30
1N5653A	64.60	71.40	1	58.10	5	92.0	90	16.3	.104	200	57.30
1N5654A	71.30	78.80	1	64.10	5	103.0	82	14.6	.105	200	63.20
1N5655A	77.90	86.10	1	70.10	5	113.0	75	13.3	.105	200	69.00
1N5656A	86.50	95.50	1	77.80	5	125.0	68	12.0	.106	200	76.50
1N5657A	95.00	105.00	1	85.50	5	137.0	62	11.0	.106	200	84.10
1N5658A	105.00	116.00	1	94.00	5	152.0	55	9.9	.107	200	92.80
1N5659A	114.00	126.00	1	102.00	5	165.0	50	9.1	.107	200	100.00
1N5660A	124.00	137.00	1	111.00	5	179.0	47	8.4	.107	200	109.00
1N5661A	143.00	158.00	1	128.00	5	207.0	40	7.2	.108	200	126.00
1N5662A	152.00	168.00	1	136.00	5	219.0	38	6.8	.108	200	134.00
1N5663A	162.00	179.00	1	145.00	5	234.0	36	6.4	.108	200	143.00
1N5664A	171.00	189.00	1	154.00	5	246.0	34	6.1	.108	200	151.00
1N5665A	190.00	210.00	1	171.00	5	274.0	30	5.5	.108	200	167.00
1N5558	191.00		1	175.00	5	265.0	33	5.7	.100	200	172.00

11

MIL-PRF-19500/500E  
w/AMENDMENT 1

TABLE III. Groups B and C electrical and delta measurements. 1/ 2/ 3/

Step	Inspection	MIL-STD-750		Symbol	Limits <u>4/</u>		Unit
		Method	Conditions		Min	Max	
1.	Standby current	4016	DC method, $V_R = V_{WM}$ (column 4 of <a href="#">table II</a> )	$I_D$		Column 5	$\mu\text{A dc}$
2.	Breakdown voltage	4022	$t_p \leq 300$ ms, duty cycle $\leq 2$ percent, $I_{BR} =$ column 3 of <a href="#">table II</a>	$V_{BR}$	Column 2	Column 2	V dc
3.	Standby current	4016	DC method; $V_R = V_{WM}$ (column 4 of <a href="#">table II</a> )	$\Delta I_D$		100 percent of initial reading or 20 percent of column 5 of <a href="#">table II</a> , whichever is greater.	
4.	Breakdown voltage	4022	$t_p \leq 300$ ms, duty cycle $\leq 2$ percent, $I_{BR} =$ column 3 of <a href="#">table II</a>	$\Delta V_{BR}$		$\pm 5$ percent of initial value	
5.	Clamping voltage		$t_p = 1.0$ ms (see <a href="#">4.5.2.a</a> ); $I_{PP} =$ column 7 of <a href="#">table II</a>	$V_C$		Column 6	V (pk)

- 1/ The electrical measurements for table E-VIb (JAN, JANTX, and JANTXV) of MIL-PRF-19500 are as follows:  
a. Subgroup 2, see table III herein, steps 1 and 2.  
b. Subgroup 6, see table III herein, steps 1, 2, 3, and 4.
- 2/ The electrical measurements for table E-VII (JAN, JANTX, and JANTXV) of MIL-PRF-19500 are as follows:  
a. Subgroup 2 and 3, see table III herein, and steps 1 and 2.  
b. Subgroup 9, see table III herein, steps 1 and 2 for all levels.
- 3/ Column references are to table II.
- 4/ Devices which exceed the table I limits for this test shall not be accepted.

MIL-PRF-19500/500E  
w/AMENDMENT 1

TABLE IV. Group E inspection (all quality levels) for qualification only.

Inspection	MIL-STD-750		Sampling plan
	Method	Conditions	
<u>Subgroup 1</u>			n = 45, c = 0
Temperature cycling	1051	500 cycles, condition C, -55°C to +175°C.	
Electrical measurements		See <a href="#">table III</a> , steps 1, 2, 3, and 4.	
<u>Subgroup 2</u>			n = 22, c = 0
Life test		1,000 hours. See <a href="#">4.3.1</a>	
Electrical measurements		See <a href="#">table III</a> , steps 1, 2, 3, and 4.	
<u>Subgroups 4 and 5</u>			
Not applicable			
<u>Subgroup 6</u>			
Peak pulse current		See <a href="#">4.5.2</a> . Ipp shall be characterized by the supplier and this data shall be available to the government. Test shall be performed on each low and high voltage device for each structurally identical grouping. Test to failure.	
Electrical measurements		See <a href="#">table III</a> , steps 1, 2, 3, and 4.	
<u>Subgroup 7</u>			n = 45, c = 0
Soldering heat	2031	1 cycle.	

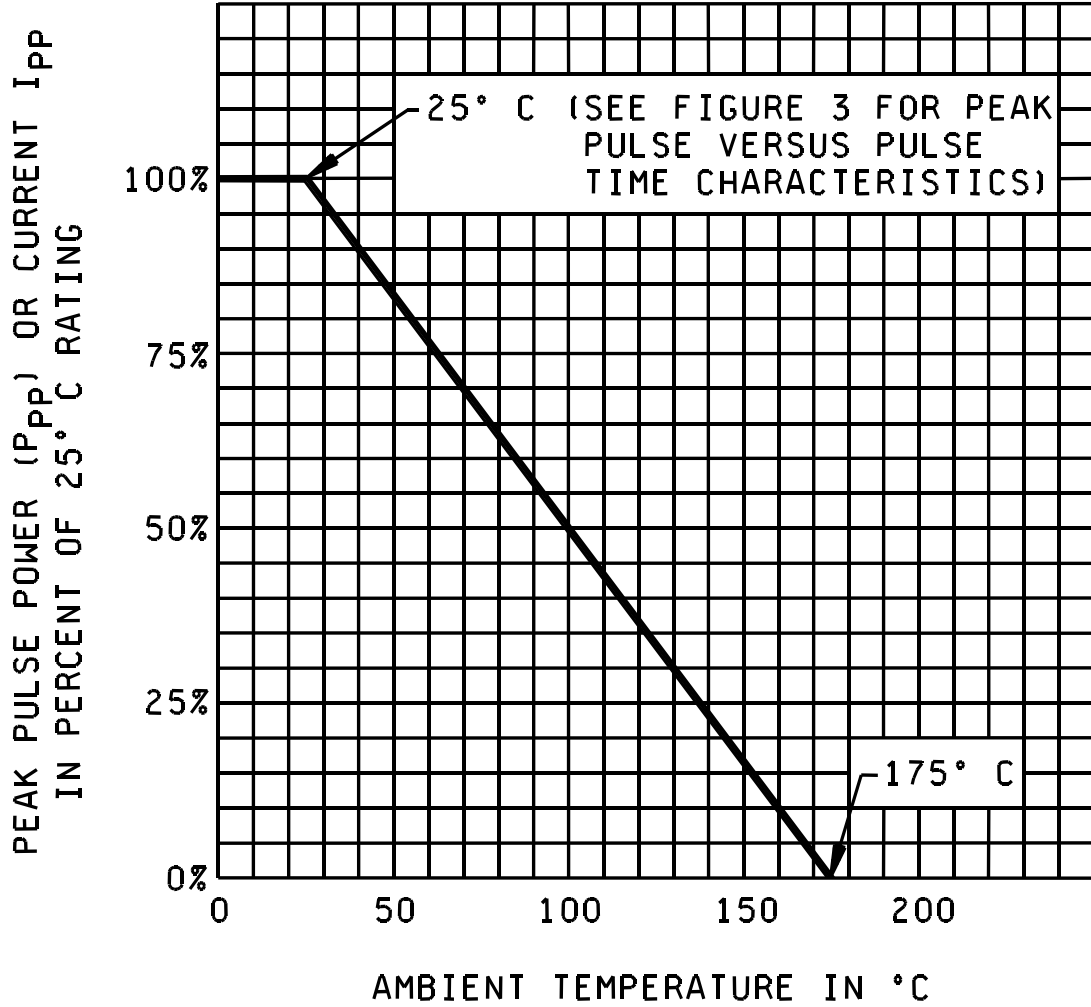

FIGURE 2. Derating curve.

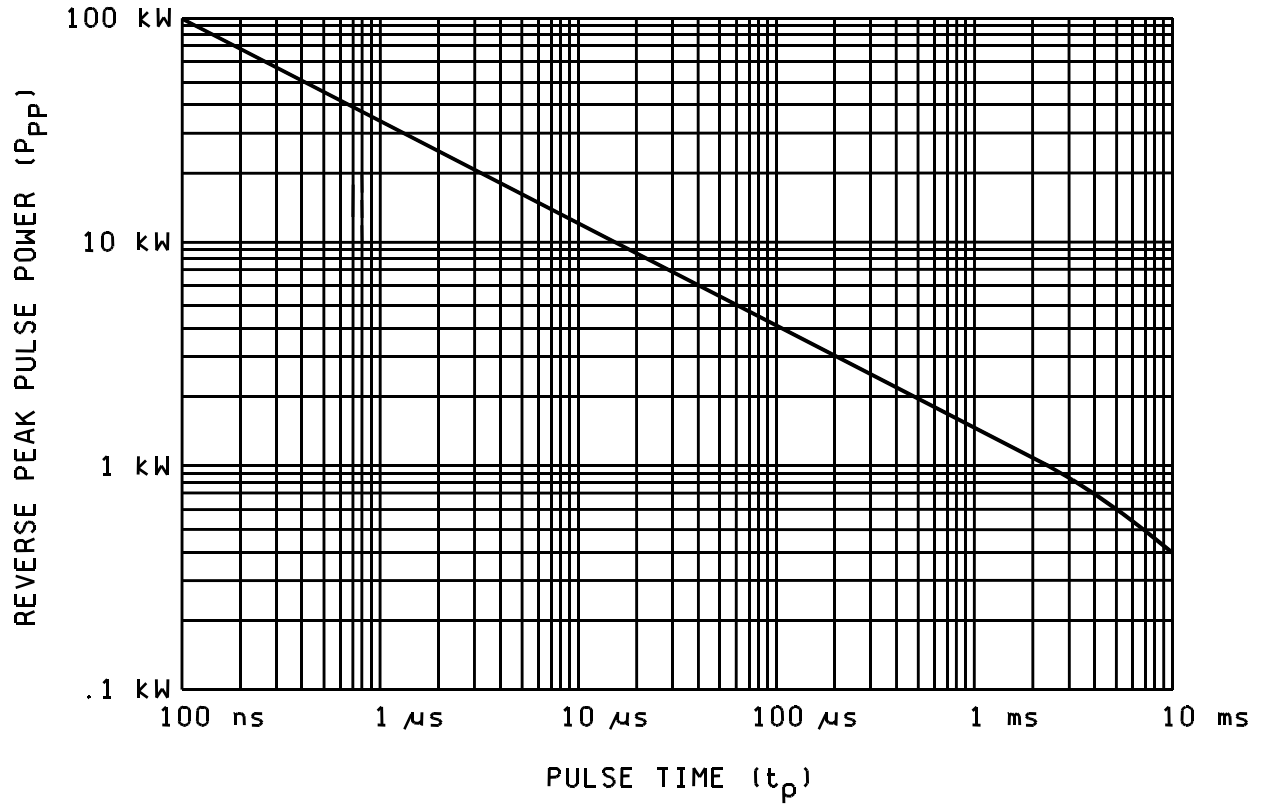
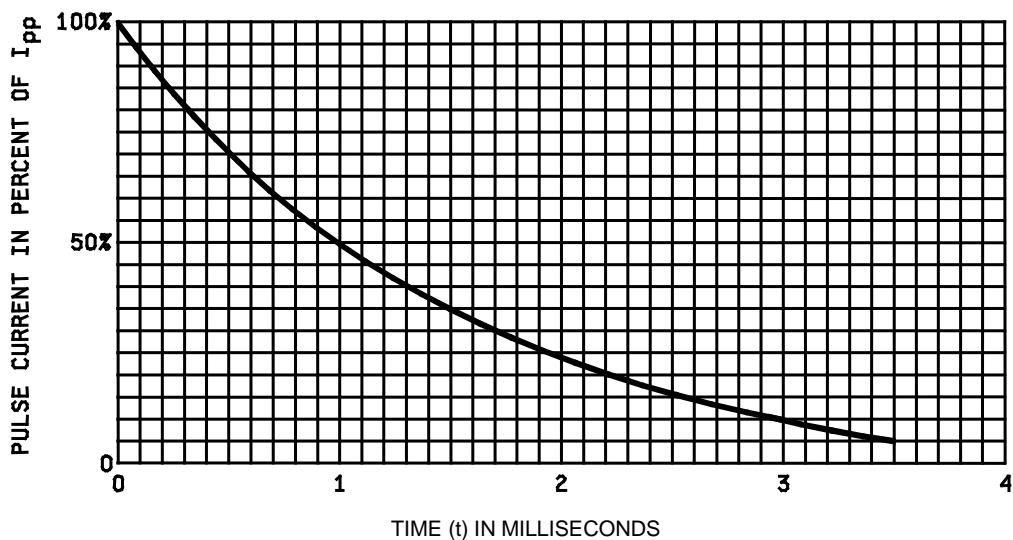
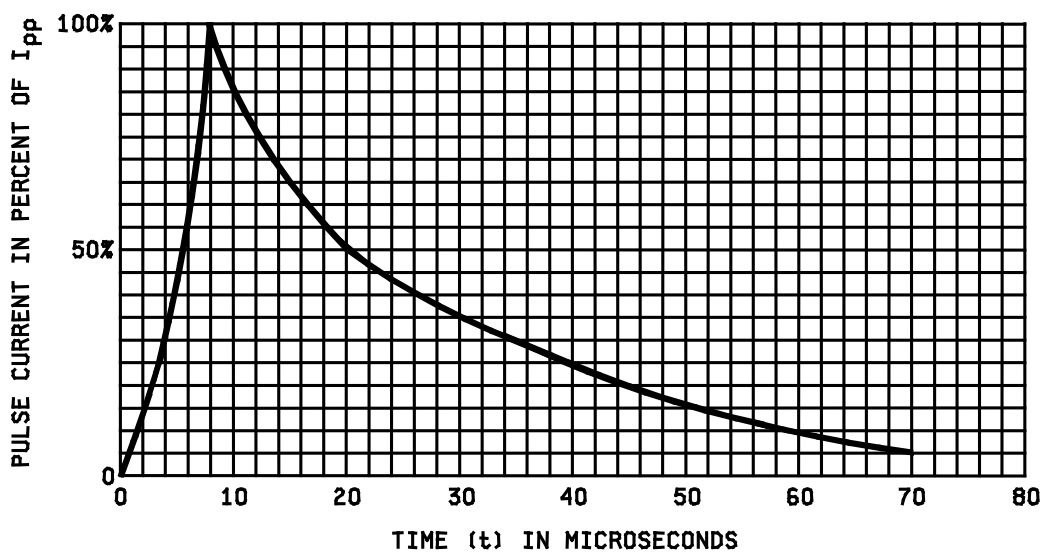

FIGURE 3. Peak pulse power versus pulse time.



NOTE: Pulse time duration is defined as that point where the pulse current decays to 50 percent of I<sub>pp</sub>. (Rise time to 100 percent of I<sub>pp</sub> = 10 μs).

FIGURE 4. Current impulse waveform (see 4.5.2.a herein).



NOTE: Pulse time duration is defined as that point where the pulse current decays to 50 percent of I<sub>pp</sub>. (Rise time to 100 percent of I<sub>pp</sub> = 8 μs).

FIGURE 5. Current impulse waveform (see 4.5.2.b herein).



## 5. PACKAGING

5.1 Packaging. For acquisition purposes, the packaging requirements shall be as specified in the contract or order (see 6.2). When packaging of materiel is to be performed by DoD or in-house contractor personnel, these personnel need to contact the responsible packaging activity to ascertain packaging requirements. Packaging requirements are maintained by the Inventory Control Point's packaging activities within the Military Service or Defense Agency, or within the Military Service's system commands. Packaging data retrieval is available from the managing Military Department's or Defense Agency's automated packaging files, CD-ROM products, or by contacting the responsible packaging activity.

## 6. NOTES

(This section contains information of a general or explanatory nature that may be helpful, but is not mandatory. The notes specified in MIL-PRF-19500 are applicable to this specification.)

6.1 Intended use. Semiconductors conforming to this specification are intended for original equipment design applications and logistic support of existing equipment.

6.2 Acquisition requirements. Acquisition documents should specify the following:

- a. Title, number, and date of this specification.
- b. Packaging requirements (see 5.1).
- c. Lead finish (see 3.4.2).
- d. Product assurance level and type designator.
- e. Destructive physical analysis when requested.

\* 6.3 Qualification. With respect to products requiring qualification, awards will be made only for products which are, at the time of award of contract, qualified for inclusion in Qualified Manufacturers List (QML 19500) whether or not such products have actually been so listed by that date. The attention of the contractors is called to these requirements, and manufacturers are urged to arrange to have the products that they propose to offer to the Federal Government tested for qualification in order that they may be eligible to be awarded contracts or orders for the products covered by this specification. Information pertaining to qualification of products may be obtained from DLA Land and Maritime, ATTN: VQE, P.O. Box 3990, Columbus, OH 43218-3990 or e-mail [vqe.chief@dla.mil](mailto:vqe.chief@dla.mil). An online listing of products qualified to this specification may be found in the Qualified Products Database (QPD) at <https://assist.dla.mil>.

6.4 Substitution information. Type numbers 1N5555 through 1N5558 were previously covered by MIL-PRF-19500/434.

6.5 Steady state power rating. This rating is not relevant for most applications.

\* 6.6 Amendment notations. The margins of this specification are marked with asterisks to indicate modifications generated by this amendment. This was done as a convenience only and the Government assumes no liability whatsoever for any inaccuracies in these notations. Bidders and contractors are cautioned to evaluate the requirements of this document based on the entire content irrespective of the marginal notations and relationship to the last previous issue.

MIL-PRF-19500/500E  
w/AMENDMENT 1

Custodians:

Army - CR  
Navy - EC  
Air Force - 85  
NASA - NA  
DLA - CC

Preparing activity:

DLA - CC

(Project 5961-2013-071)

Review activities:

Army - AR, MI, SM  
Navy - AS, MC  
Air Force - 19, 99

\* NOTE: The activities listed above were interested in this document as of the date of this document. Since organizations and responsibilities can change, you should verify the currency of the information above using the ASSIST Online database at <https://assist.dla.mil> .