

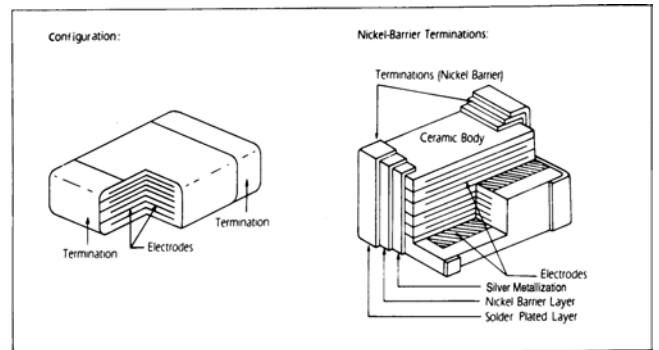

FEATURES AND APPLICATIONS

Dielectric	Features	Applications
COG (NPO)	<ul style="list-style-type: none"> Ultra-stable Low dissipation factor Tight tolerance available Good frequency performance No aging of capacitance 	<ul style="list-style-type: none"> LC and RC tuned circuit Filtering Timing
X7R/X5R	<ul style="list-style-type: none"> Semi-stable high K High volumetric efficiency Highly reliable in high temperature applications High insulation resistance 	<ul style="list-style-type: none"> Blocking Coupling Timing Bypassing Frequency discriminating Filtering
Y5V	<ul style="list-style-type: none"> Highest volumetric efficiency Non-polar construction General purpose, high K 	<ul style="list-style-type: none"> Bypassing Decoupling Filtering

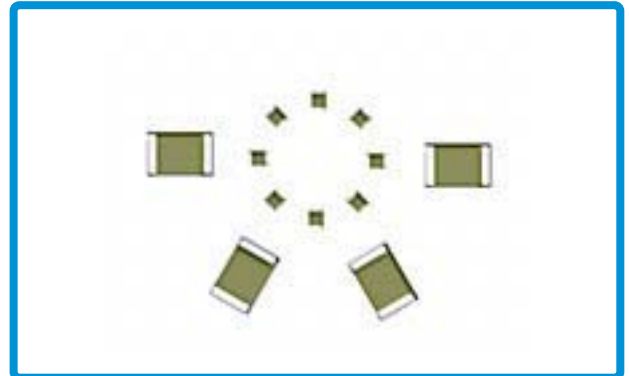

PART NUMBERING SYSTEM

Meritek Series	MA	1206	XR	103	K	500		
Size								
Dielectric								
CODE	CG	XR	XF	YV				
	COG (NPO)	X7R	X5R	Y5V				
Capacitance								
CODE	8R2	101	223	104				
pF	8.2	100	22000	100000				
nF	--	0.1	22	100				
µF	--	--	0.022	0.1				
Tolerance								
CODE	Tolerance	CODE	Tolerance	CODE	Tolerance			
B	±.1pF	C	±.25pF	D	±.5pF			
F	±1%	G	±2%	J	±5%			
K	±10%	M	±20%	Z	+80/-20%			
For values less than 10 pF C or D tolerance preferred								
Rated Voltage								
Code	250	500	101	251	501	102	202	302
	25V	50V	100V	250V	500V	1000V	2000V	3000V

EIA CASE SIZE	0201	0402	0603	0805	1206	1210	1812	2225
Length (L)	0.6 ±0.03	1.0 ±0.05	1.6 ±0.15	2.0 ±0.2	3.2 ±0.2	3.2 ±0.3	4.5 ±0.3	5.7 ±0.4
Width (W)	0.3 ±0.03	0.5 ±0.05	0.8 ±0.15	1.25 ±0.2	1.6 ±0.12	2.5 ±0.3	3.2 ±0.3	6.35 ±0.25
Max. Thickness (T)	0.30	0.60	1.0	1.30	1.50	1.70	1.70	1.78
Termination Width (E)	0.15 ±0.05	0.2 ±0.1	0.4 ±0.2	0.5 ±0.2	0.6 ±0.2	0.75 ±0.25	0.75 ±0.25	0.75 ±0.25

PERFORMANCE SPECIFICATION

1. ELECTRICAL

DIELECTRIC CODE	EIA	NPO	X7R	Y5V
Temperature Characteristics *1		0 ± 30ppm/°C, C > 20pF 0 ⁺¹²⁰ / ₋₄₀ ppm/°C, C ≤ 20pF	ΔC ± 15% maximum over -55°C to +125°C	ΔC + 22/-82% maximum over -30°C to +85°C
Operating Temperature Range		-55°C to +125°C	-55°C to +125°C	-30°C to +85°C
Measuring Conditions for Capacitance and D.F. *2		1MHz, 1Vrms, C ≤ 1000pF 1 KHz, 1 Vrms, C > 1000pF	1KHz, 1Vrms	1KHz, 10Vrms
Dissipation Factor (D.F.) and Tangent of Loss Angle (tan)		≤ 0.1% for C ≥ 30pF ≤ ^{100%} / _(400+20C) for C < 30pF	≤ 2.5% at ≥ 50V rated ≤ 3.5% at 16V, 25V rated ≤ 5.0% at 6.3V, 10V rated	≤ 5% at 50V rated ≤ 7% at 16V, 25V rated ≤ 10% at 6.3V, 10V rated
Insulation Resistance (I.R.) after 60 secs. charging at rated voltage, 25°C, 55% RH max.		≥ 100G Ω or ≥ 1000M Ω μF whichever is less	≥ 10G Ω or ≥ 100M Ω μF whichever is less	≥ 10G Ω or ≥ 100M Ω μF whichever is less
Voltage Proof, 25 °C, 1-5 secs.		2.5 x Rated Voltage	2.5 x Rated Voltage	2.5 x Rated Voltage
Capacitance Aging		0	≈ 2.5% per decade hour	≈ 7% per decade hour

*1 Class II (X7R, Z5U, Y5V) capacitors shall be made a special pre-conditioning before a test or a sequence of tests under the following conditions: Exposure at 150 ± 10°C for 1 hr, followed by setting the capacitor at room temperature for 24 ± 1 hr.

*2 Capacitance is within specified tolerance; measured 1000 hours after date of manufacture because of capacitance aging of Class II capacitor.

2. ENVIRONMENTAL

Test	Test Conditions	Post-Test Inspection Requirements		
Solderability	IEC 384-10 4.11 / JIS C 5102 8.13 Solder 60 Sn/40 Pb, 235 ± 5°C Immersed for 5 secs.	At least 75% of termination area should be well tinned No visible damage		
Resistance to Soldering Heat *1	IEC 384-10 4.10 / JIS C 5102 8.14 Immersed in solder bath at 260 ± 5°C for 10 ± 1 secs. Recovery: 6 to 24 hrs. (NPO) 24 ± 2 hrs. (X7R, Y5V)	At least 75% of termination should be covered by solder No visible damage		
		NPO	X7R	Y5V
		ΔC/C ≤ ±0.5% or ±0.5pF whichever is greater	≤ +10/-5%	≤ +20/-10%
Rapid Change of Temperature *2	IEC 384-10 4.12 / JIS C 5102 9.3 -55°C to +125°C, 5 cycles (NPO, X7R) Duration: 30 mins. Recovery: 6 to 24 hrs. (NPO) 24 ± 2 hrs. (X7R)	No visible damage		
		ΔC/C	NPO	X7R
			≤ ±1% or ±1pF whichever is greater	≤ ±10%
		D.F.	≤ 1.5 x initial requirement	
		I.R.	≥ 0.25 x initial requirement	
Endurance (Life Test) *3	IEC 384-10 4.15 1000 hrs. at maximum temperature with x 1.5 rated voltage applied Recovery: 6 to 24 hrs. (NPO) 24 ± 2 hrs. (X7R, Y5V)	No visible damage		
		NPO	X7R	Y5V
		ΔC/C ≤ ±2% or ±1pF whichever is greater	≤ ±20%	≤ ±30%
		D.F.	≤ 1.5 x initial requirement	
		I.R.	≥ 0.25 x initial requirement	
Humidity Test (Damp heat, steady state) *4	IEC 384-10 4.14 / JIS C 5102 9.5 500 hrs. at 40 ± 2°C, 90-95% RH Recovery: 6 to 24 hrs. (NPO) 24 ± 2 hrs. (X7R, Y5V)	No visible damage		
		NPO	X7R	Y5V
		ΔC/C ≤ ±2% or ±1pF whichever is greater	≤ ±10%	≤ ±30%
		D.F.	≤ 1.5 x initial requirement	
		I.R.	≥ 0.25 x initial requirement	
Adhesion	IEC 384-10 4.8 / JIS C 5102 8.11.2 Capacitors mounted on a substrate, a force of 5N applied perpendicular to the plane of substrate and parallel to the line joining the center of terminations for 10 ± 1 secs.	No visible damage		

*1-4 Class II (X7R, Y5V) capacitors shall be made a special pre-conditioning before a test or a sequence of tests under the following conditions: Exposure at 150 ± 10°C for 1 hr, followed by setting the capacitor at room temperature for 24 ± 1 hr.

MLCC Product Information

Application	Series	Dielectric	Size	Capacitance	Rated voltage
General Purpose	MA	NPO	0201,0402, 0603,0805,1206, 1210, 1812	0.5pF ~ 0.039μF	16V, 25V, 50V, 100V
		X7R	0201,0402, 0603,0805,1206, 1210, 1812	100pF ~ 1μF	10V, 16V, 25V, 50V, 100V
		Y5V	0402, 0603,0805,1206, 1210, 1812	0.01uF ~ 1μF	10V, 16V, 25V, 50V, 100V
High Capacitance	MA	X7R	0402, 0603,0805,1206, 1210, 1812	0.1uF ~ 22μF	6.3V, 10V, 16V, 25V, 50V
		X5R	0201,0402, 0603,0805,1206	0.027uF ~ 10μF	6.3V, 10V, 16V
		Y5V	0402, 0603,0805,1206, 1210, 1812	0.15uF ~ 47μF	6.3V, 10V, 16V, 25V, 35V, 50V
Low Inductance	MA	X7R	0612	0.01uF ~ 0.15μF	50V
High Q & Low ESR	HQ	NPO	0402, 0603,0805	0.5pF ~ 3300μF	16V, 25V, 50V, 100V
Open-mode Design	OP	X7R	0805,1206, 1210, 1812	100pF ~ 1μF	100V, 200V, 250V, 500V
High Voltage	HC	NPO	0805,1206, 1210, 1808, 1812	10pF ~ 6800pF	200V, 250V, 500V, 630V, 1kV, 2kV, 3kV
		X7R	0805,1206, 1210, 1808, 1812	100pF ~ 0.1μF	200V, 250V, 500V, 630V, 1kV, 1.5kV, 2kV, 3kV
		Y5V	0805,1206, 1210, 1812	0.01uF ~ 0.68μF	200V, 250V
Capacitor Arrays	CI	NPO	0612 (4 x 0603)	10pF ~ 470pF	50V
		X7R	0612 (4 x 0603)	680pF ~ 0.1μF	16V,25V,50V
		Y5V	0612 (4 x 0603)	0.022uF ~ 0.15μF	16V,25V,50V
Safety capacitors (X2/Y3)	MSC	NPO	1808	5pF ~ 680pF	250Vac
		X7R	1808	150pF ~ 1500pF	250Vac

Multilayer Ceramic Chip Capacitors

MA Series

MERITEK

NPO CAPACITANCE RANGE CHART

EIA CASE SIZE		0201		0402		0603			0805		1206		1210		1812		2225	
Working Voltage		16	25	25	50	25	50	100	50	100	50	100	50	100	50	100	50	100
Cap	0.5	0R5																
(pF)	1.0	1R0																
	1.2	1R2																
	1.5	1R5																
	1.8	1R8																
	2.2	2R2																
	2.7	2R7																
	3.3	3R3																
	3.9	3R9																
	4.7	4R7																
	5.6	5R6																
	6.8	6R8																
	8.2	8R2																
	10	100																
	12	120																
	15	150																
	18	180																
	22	220																
	27	270																
	33	330																
	39	390																
	47	470																
	56	560																
	68	680																
	82	820																
	100	101																
	120	121																
	150	151																
	180	181																
	220	221																
	270	271																
	330	331																
	390	391																
	470	471																
	560	561																
	680	681																
	820	821																
	1000	102																
	1200	122																
	1500	152																
	1800	182																
	2200	222																
	3300	332																
	3900	392																
	4700	472																
	5600	562																
	6800	682																
	8200	822																
	0.010	103																
	0.012	123																
	0.015	153																
	0.018	183																
	0.022	223																
	0.027	273																
	0.033	333																
	0.039	393																
	0.047	473																
	0.056	563																
	0.068	683																
	0.082	823																

Some special values available upon request.

X7R CAPACITANCE RANGE CHART (0201 to 1206)

EIA CASE SIZE			0201		0402				0603				0805				1206			
Working Voltage			25	50	10	16	25	50	10	16	25	50	10	16	25	50	10	16	25	50
Cap	100	101																		
(pF)	120	121																		
	150	151																		
	180	181																		
	220	221																		
	270	271																		
	330	331																		
	390	391																		
	470	471																		
	560	561																		
	680	681																		
	820	821																		
	1000	102																		
	1200	122																		
	1500	152																		
	1800	182																		
	2200	222																		
	2700	272																		
	3300	332																		
	3900	392																		
	4700	472																		
	5600	562																		
	6800	682																		
	8200	822																		
	0.010	103																		
	0.012	123																		
	0.015	153																		
	0.018	183																		
	0.022	223																		
	0.027	273																		
	0.033	333																		
	0.039	393																		
	0.047	473																		
	0.056	563																		
	0.068	683																		
	0.082	823																		
	0.10	104																		
	0.12	124																		
	0.15	154																		
	0.18	184																		
	0.22	224																		
	0.27	274																		
	0.33	334																		
	0.39	394																		
	0.47	474																		
	0.56	564																		
	0.68	684																		
	0.82	824																		
	1.0	105																		
	1.5	155																		
	1.8	185																		
	2.2	225																		
	2.7	275																		
	3.3	335																		
	3.9	395																		
	4.7	475																		
	5.6	565																		
	6.8	685																		
	10.0	106																		
	22	226																		

Some special values available upon request.

X7R CAPACITANCE RANGE CHART (1210 to 2225)

EIA CASE SIZE			1210					1812					2225		
Working Voltage			6.3	10	16	25	50	10	16	25	50	100	25	50	100
Cap	1000	102													
(pF)	1200	122													
	1500	152													
	1800	182													
	2200	222													
	2700	272													
	3300	332													
	3900	392													
	4700	472													
	5600	562													
	6800	682													
	8200	822													
	0.010	103													
	0.012	123													
	0.015	153													
	0.018	183													
	0.022	223													
	0.027	273													
	0.033	333													
	0.039	393													
	0.047	473													
	0.056	563													
	0.068	683													
	0.082	823													
	0.10	104													
	0.12	124													
	0.15	154													
	0.18	184													
	0.22	224													
	0.27	274													
	0.33	334													
	0.39	394													
	0.47	474													
	0.56	564													
	0.68	684													
	0.82	824													
	1.0	105													
	1.5	155													
	1.8	185													
	2.2	225													
	2.7	275													
	3.3	335													
	3.9	395													
	4.7	475													
	5.6	565													
	6.8	685													
	10.0	106													
	22	226													

Some special values available upon request.

X5R CAPACITANCE RANGE CHART (0201 to 1206)

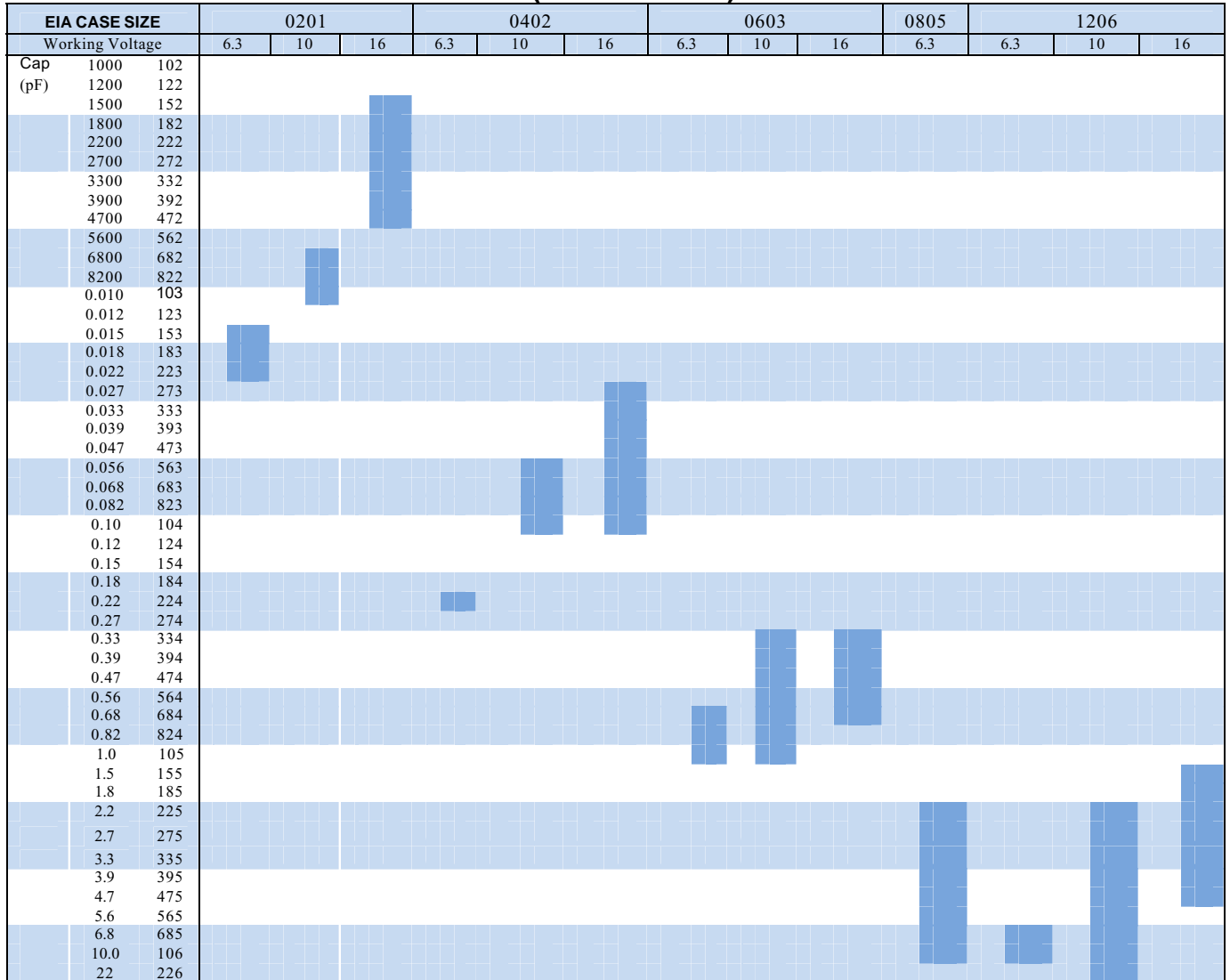

Some special values available upon request.

Y5V CAPACITANCE RANGE CHART

EIA CASE SIZE		0402				0603				0805				1206				1210				
Working Voltage		10	16	25	50	10	16	25	50	10	16	25	50	10	16	25	50	10	16	25	50	
Cap	2200	222																				
(pF)	2700	272																				
	3300	332																				
	3900	392																				
	4700	472																				
	5600	562																				
	6800	682																				
	8200	822																				
	0.010	103																				
	0.012	123																				
	0.015	153																				
	0.018	183																				
	0.022	223																				
	0.027	273																				
	0.033	333																				
	0.039	393																				
	0.047	473																				
	0.056	563																				
	0.068	683																				
	0.082	823																				
	0.10	104																				
	0.12	124																				
	0.15	154																				
	0.18	184																				
	0.22	224																				
	0.27	274																				
	0.33	334																				
	0.39	394																				
	0.47	474																				
	0.56	564																				
	0.68	684																				
	0.82	824																				
	1.0	105																				
	1.2	125																				
	1.5	155																				
	1.8	185																				
	2.2	225																				
	2.7	275																				
	3.3	335																				
	3.9	395																				
	4.7	475																				
	5.6	565																				
	6.8	685																				
	10	106																				
	22.0	226																				

Some special values available upon request.

Multilayer Ceramic Capacitors



MA

Low Inductance Series

MERITEK

FEATURES

- Reversed geometry termination type
- Low ESL, low ESR
- Noise reduction for high frequency

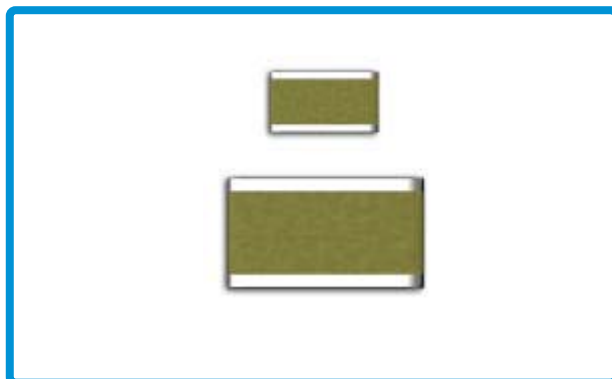

PART NUMBER SYSTEM

MA 0612 XR 103 K 500

Meritek Series

Size

Dielectric

CODE	XR
	X7R

Capacitance

Expressed in picofarads. First 2 digits are significant digits. Third digit denotes number of zeros to follow. Use R for decimal point for values less than 10pF.

CODE	103	124
μF	0.01	0.12

Tolerance

CODE	B	C	D	G	J
	±.10pF	±.25pF	±.50pF	±2%	±5%

For values less than 10 pF use C or D

Rated Voltage

2 significant digits + number of zeros.

CODE	250	500
	25V	50V

X7R CAPACITANCE RANGE CHART

EIA CASE SIZE		0612
Working Voltage		50
Cap (μF)	0.010 103	
	0.012 123	
	0.015 153	
	0.018 183	
	0.022 223	
	0.027 273	
	0.033 333	
	0.039 393	
	0.047 473	
	0.056 563	
	0.068 683	
	0.082 823	
	0.10 104	
	0.12 124	
	0.15 154	

Some special values available upon request

Multilayer Ceramic Capacitors

HQ Series
(High Q)

MERITEK



FEATURES

- Surface mount device with high reliability
- Hi-Q and low ESR at high frequencies
- Low capacitance with tight tolerance
- Excellent temperature characteristics

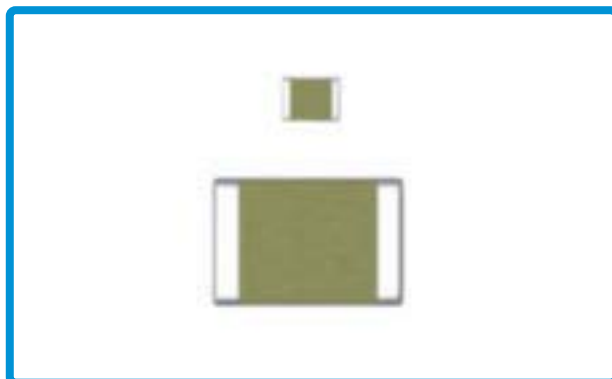

PART NUMBER SYSTEM

HQ
0603
CG
4R7
B
500

Meritek Series

Size

Dielectric

CODE	CG
	COG (NPO)

Capacitance

Expressed in picofarads. First 2 digits are significant digits. Third digit denotes number of zeros to follow. Use R for decimal point for values less than 10pF.

CODE	8R2	101
pF	8.2	100

Tolerance

CODE	B	C	D	G	J
	±.10pF	±.25pF	±.50pF	±2%	±5%

For values less than 10 pF use C or D

Rated Voltage

2 significant digits + number of zeros.

CODE	250	500
	25V	50V

ELECTRICAL CHARACTERISTICS

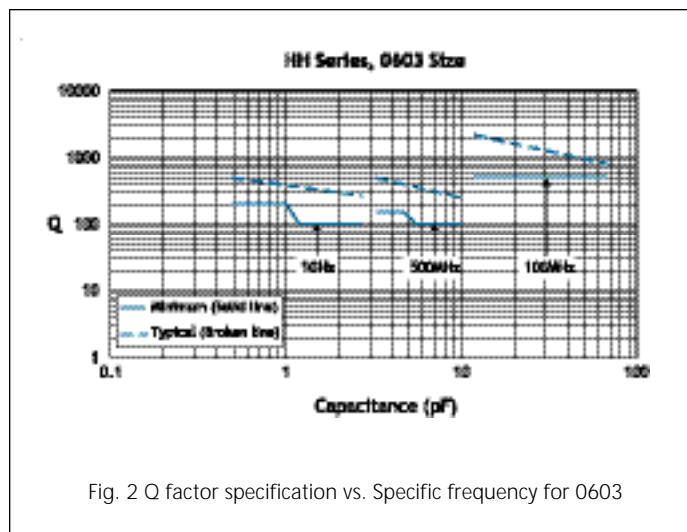
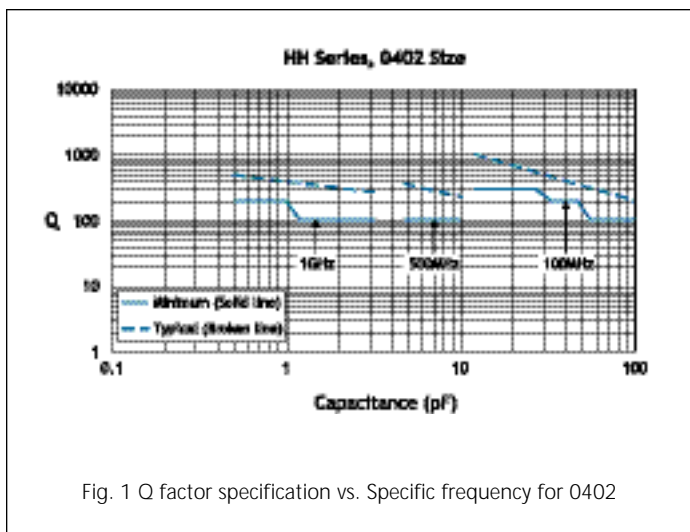

Multilayer Ceramic Capacitors



HQ Series
(High Q)

MERITEK

NPO CAPACITANCE RANGE CHART

EIA CASE SIZE			0402			0603		
Working Voltage			16	25	50	16	50	100
Cap (pF)	0.5	0R5						
	1.0	1R0						
	1.2	1R2						
	1.5	1R5						
	1.8	1R8						
	2.2	2R2						
	2.7	2R7						
	3.3	3R3						
	3.9	3R9						
	4.7	4R7						
	5.6	5R6						
	6.8	6R8						
	8.2	8R2						
	10	100						
	12	120						
	15	150						
	18	180						
	22	220						
	27	270						
	33	330						
	39	390						
	47	470						
	56	560						
	68	680						
	82	820						
	100	101						
	120	121						
	150	151						
	180	181						
	220	221						
	270	271						
	330	331						
	390	391						
470	471							
560	561							
680	681							
820	821							
1000	102							
1200	122							
1500	152							
1800	182							
2200	222							
2700	272							
3300	332							

Some special values available upon request

Multilayer Ceramic Capacitors

OPEN-MODE DESIGN



OP Series

MERITEK

FEATURES

- Minimize the short circuit probability due to flex cracks
- High current applications
- Input side filtering

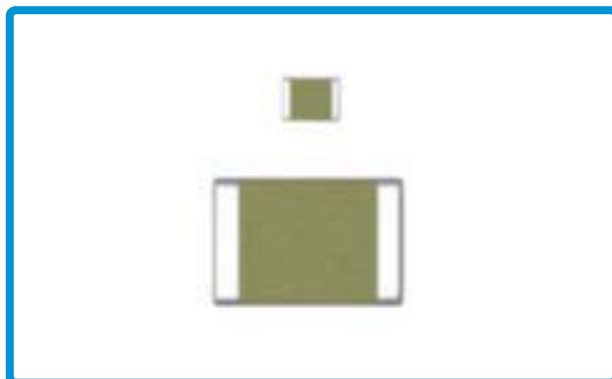

PART NUMBER SYSTEM

OP 0805 XR 101 K 500

Meritek Series

Size

Dielectric

CODE	XR
	X7R

Capacitance

Expressed in picofarads. First 2 digits are significant digits. Third digit denotes number of zeros to follow. Use R for decimal point for values less than 10pF.

CODE	8R2	101
pF	8.2	100

Tolerance

CODE	B	C	D	G	J
	±.10pF	±.25pF	±.50pF	±2%	±5%

For values less than 10 pF use C or D

Rated Voltage

2 significant digits + number of zeros.

CODE	250	500
	25V	50V

INNER CONSTRUCTION OF OPEN-MODE DESIGN

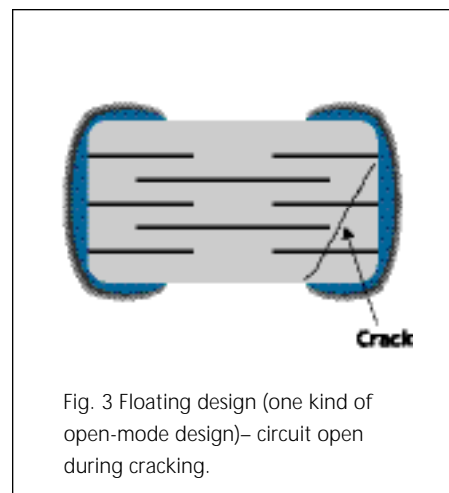
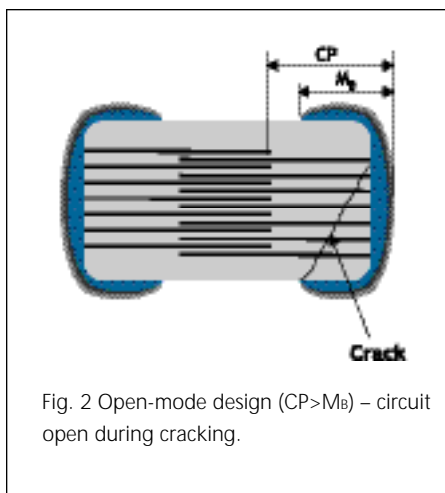
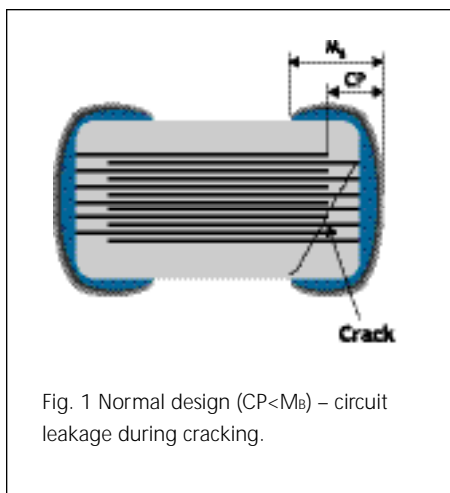

Multilayer Ceramic Capacitors

OPEN-MODE DESIGN

OP Series

MERITEK

X7R CAPACITANCE RANGE CHART

EIA CASE SIZE		0805				1206				1210				1812			
Working Voltage		100	200	250	500	100	200	250	500	100	200	250	500	100	200	250	500
Cap (pF)	100	101															
	120	121															
	150	151															
	180	181															
	220	221															
	270	271															
	330	331															
	390	391															
	470	471															
	560	561															
	680	681															
	820	821															
	1000	102															
	1200	122															
	1500	152															
	1800	182															
	2200	222															
	2700	272															
	3300	332															
	3900	392															
	4700	472															
	5600	562															
	6800	682															
	8200	822															
	0.010	103															
	0.012	123															
	0.015	153															
	0.018	183															
	0.022	223															
	0.027	273															
	0.033	333															
	0.039	393															
	0.047	473															
	0.056	563															
	0.068	683															
	0.082	823															
	0.10	104															
	0.12	124															
	0.15	154															
	0.18	184															
	0.22	224															
	0.27	274															
	0.33	334															
	0.39	394															
	0.47	474															
	0.56	564															
	0.68	684															
	0.82	824															
	1.0	105															

Some special values available upon request

Multilayer Ceramic Chip Capacitors



HC Series
(High Voltage)

MERITEK

PECIFICATIONS

CODE	NPO (1B)	X7R (2R1)
Temperature Characteristics	0 ±30ppm/°C	ΔC ±15% (-55°C to +125°C)
Dissipation Factor (D.F.)	0.15% max. (+25°C, 1Vrms, 1MHz)	2.5% max. (+25°C, 1Vrms, 1 KHz)
Insulation Resistance	100000MΩ or 1000MΩ • μF whichever is less	100000MΩ or 1000MΩ • μF whichever is less
Dielectric Withstanding Voltage	120% rated voltage, 25°C, 5 sec.	120% rated voltage, 25°C, 5 sec.
Standard Tolerance	J (±5%), K (±10%), M (±20%)	J (±5%), K (±10%), M (±20%)
Termination Material	Nickel-Barrier, Solder Plated	Nickel-Barrier, Solder Plated

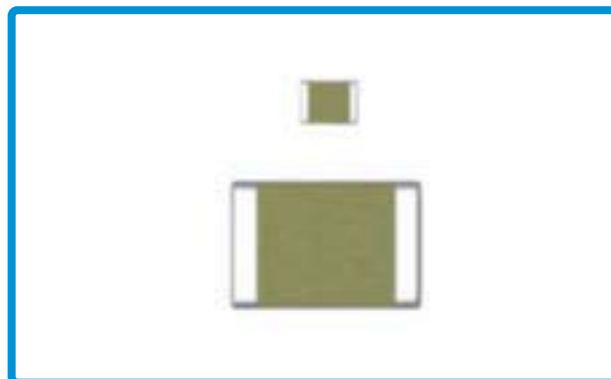

MERITEK High Voltage Chip Capacitors are developed for circuits requiring reliable components in high voltage applications, such as high voltage solid state multipliers, high voltage power supplies, high voltage rectifier arrays, and other similar applications

PART NUMBERING SYSTEM

	HC	1206	XR	101	K	501
Meritek Series						
Size						
Dielectric						
CODE	CG	XR				
	COG (NPO)	X7R				
Capacitance						
CODE	8R2	101	223	104		
pF	8.2	100	22000	100000		
nF	--	.1	22	100		
μF	--	--	0.022	0.1		
Tolerance						
Code	Tolerance	Code	Tolerance	Code	Tolerance	
F	±1%	G	±2%	J	±5%	
K	±10%	M	±20%	Z	+80/-20%	
Rated Voltage						
2 significant digits + number of zeros						
Code	101	251	501	102	202	302
R.V.	100V	250V	500V	1000V	2000V	3000V

Multilayer Ceramic Chip Capacitors

HC Series
(High Voltage)

MERITEK

COG (NPO) Capacitance Range Chart 0805 to 1808

Dimensions in millimeters (mm)

Size			0805		1206				1210					1808				
Length (L)			2.0±0.2		3.2±0.2				3.2±0.3					4.5±0.3				
Width (W)			1.20±0.2		1.60±0.2				2.50±0.3					2.0±0.2				
Thickness (T)			0.65±0.1		0.85±0.1				1.15±0.1					1.15±0.1				
Termination (E)			0.5±0.2		0.5±0.2				0.5±0.2					0.64±0.38				
	Value	Code	250V	500V	250V	500V	1KV	2KV	3KV	250V	500V	1KV	2KV	3KV	500V	1KV	2KV	3KV
Cap (pF)	10	100																
	12	120																
	15	150																
	18	180																
	22	220																
	27	270																
	33	330																
	39	390																
	47	470																
	56	560																
	68	680																
	82	820																
	100	101																
	120	121																
	150	151																
	180	181																
	220	221																
	270	271																
	330	331																
	390	391																
	470	471																
	560	561																
	680	681																
	820	821																
	1000	102																
	1200	122																
	1500	152																
	1800	182																
	2200	222																
	2700	272																
	3300	332																
	3900	392																
	4700	472																
	5600	562																
	6800	682																

Notes:

1) T=1.10±0.1

2) T=1.60±0.1

1) T=1.45±0.1

2) T=1.65±0.1

1) T=1.45±0.1

2) T=1.65±0.1

COG (NPO) Capacitance Range Chart 1812 to 5550

Dimensions in millimeters (mm)

Size			1812					2220		3530		4540		5550	
Length (L)			4.5±0.3					5.7±0.4		8.9±0.4		11.4±0.4		14.0±0.4	
Width (W)			3.20±0.3					5.0±0.4		7.6±0.4		10.2±0.4		12.5±0.4	
Thickness (T)			1.15±0.1					2.5±0.1		3.8±0.1		3.8±0.1		3.8±0.1	
Termination (E)			0.64±0.38					0.64±0.38		0.75±0.38		0.75±0.38		0.75±0.38	
	Value	Code	250V	500V	1KV	2KV	3KV	1KV	2KV	1KV	2KV	1KV	2KV	1KV	2KV
Cap (pF)	10	100													
	12	120													
	?	?													
	180	181													
	220	221													
	270	271													
	330	331													
	390	391													
	470	471													
	560	561													
	680	681													
	820	821													
	1000	102													
	1200	122													
	1500	152													
	1800	182													
	2200	222													
	2700	272													
	3300	332													
	3900	392													
	4700	472													
	5600	562													
	6800	682													
	8200	822													
Cap (µF)	.010	103													
	.012	123													
	.015	153													
	.018	183													
	.022	223													
	.027	273													

Notes:

1) T=1.15±0.1

2) T=1.65±0.1

3) T=2.00±0.1

Other capacitance values and voltages available upon request

Thickness may change due to improvement in production technology

Multilayer Ceramic Chip Capacitors

HC Series
(High Voltage)

MERITEK

X7R Capacitance Range Chart 0805 to 1808

Dimensions in millimeters (mm)

Size		0805		1206				1210				1808				
Length (L)		2.0±0.2		3.2±0.2				3.2±0.3				4.5±0.3				
Width (W)		1.20±0.2		1.60±0.2				2.50±0.3				2.0±0.2				
Thickness (T)		0.65±0.1		0.85±0.1				1.15±0.1				1.15±0.1				
Termination (E)		0.5±0.2		0.5±0.2				0.5±0.2				0.64±0.38				
	Value	Code	250V	500V	250V	500V	1KV	2KV	250V	500V	1KV	2KV	500V	1KV	2KV	3KV
Cap (pF)	100	101														
	120	121														
	150	151														
	180	181														
	220	221														
	270	271														
	330	331														
	390	391														
	470	471														
	560	561														
	680	681														
	820	821														
	1000	102														
	1200	122														
	1500	152														
	1800	182														
	2200	222														
	2700	272														
	3300	332														
	3900	392														
	4700	472														
	5600	562														
	6800	682														
	8200	822														
Cap (μF)	.010	103														
	.012	123														
	.015	153														
	.018	183														
	.022	223														
	.027	273														
	.033	333														
	.039	393														
	.047	473														
	.056	563														
	.068	683														
	.082	823														
	.10	104														
Notes:			1) T=1.10±0.1		2) T=1.60±0.1		1) T=1.45±0.1		2) T=1.65±0.1		1) T=1.45±0.1		2) T=1.65±0.1		3) T=2.00±0.1	

X7R Capacitance Range Chart 1812 to 5550

Dimensions in millimeters (mm)

Size		1812			2220		3530		4540		5550			
Length (L)		4.5±0.3			5.7±0.4		8.9±0.4		11.4±0.4		14.0±0.4			
Width (W)		3.20±0.3			5.0±0.4		7.6±0.4		10.2±0.4		12.5±0.4			
Thickness (T)		1.15±0.1			2.5±0.1		3.8±0.1		3.8±0.1		3.8±0.1			
Termination (E)		0.64±0.38			0.64±0.38		0.75±0.38		0.75±0.38		0.75±0.38			
	Value	Code	250V	500V	1KV	2KV	3KV	1KV	2KV	1KV	2KV	1KV	2KV	
Cap (pF)	180	181												
	220	221												
	?	?												
	470	471												
	560	561												
	680	681												
	820	821												
	1000	102												
	1200	122												
	1500	152												
	1800	182												
	2200	222												
	2700	272												
	3300	332												
	3900	392												
	4700	472												
	5600	562												
	6800	682												
	8200	822												
Cap (μF)	.010	103												
	.012	123												
	.015	153												
	?	?												
	.033	333												
	.039	393												
	.047	473												
	.056	563												
	.068	683												
	.082	823												
	.10	104												
	.12	124												
	.15	154												
	.18	184												
	.22	224												
	?	?												
	1	106												
Notes:			1) T=1.45±0.1		2) T=1.65±0.1		3) T=2.00±0.1							

Other capacitance values and voltages available upon request

Multilayer Ceramic Chip Capacitors



CI Series
(Capacitor Array)

MERITEK

FEATURES

- Reduction in required real estate (more than 50%)
- Reduced cost, space and time for placement on PCB
- Reduction in number of solder joints
- Easier PCB design
- Reduced waste from tape and reel packaging process
- Protect EMI by bypassing digital signal line noise

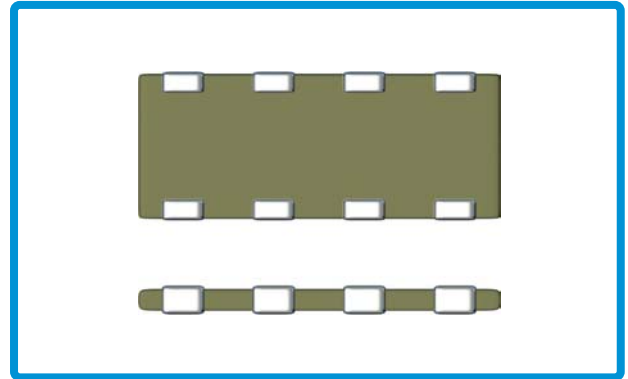

STRUCTURE AND DIMENSION

STRUCTURE AND DIMENSION

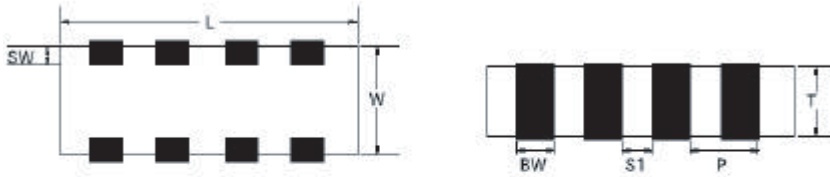

FEATURE



Type	Size (Inch)	Element	L	W	T	BW	SW	S1	P
4	0.612	4	3.2±0.15	1.6±0.15	1.35 max	0.3±0.2	0.3±0.15	0.4±0.2	0.8±0.2

Thickness: 0.85 ± 0.1mm

PART NUMBERING SYSTEM

Meritek Series, C-array

CI 1206 XR 101 K 500

Size

Dielectric

CODE	CG	XR	YV
	COG (NPO)	X7R	Y5V

Capacitance

CODE	8R2	101	104	223
pF	8.2	100	--	--
nF	--	--	100	22
μF	--	--	0.1	0.022

Tolerance

COD	Tolerance	Code	Tolerance	Code	Tolerance
E					
B	±10pF	G	±2%	M	±20%
C	±25pF	J	±5%	Z	+80/-20%
D	±50pF	K	±10%	P	+1000/0%

For values less than 10 pF use C or D

Rated Voltage
2 significant digits + number of zeros.

CODE	250	500	101	251	501	102	202	302
R.V.	25V	50V	100V	250V	500V	1000V	2000V	3000V

Temperature Characteristics	COG (NPO)	X7R			Y5V		
	Rated Voltage (DC)	16V	25V	50V	16V	25V	50V
Capacitance (pF)	50V	16V	25V	50V	16V	25V	50V
10							
15							
22							
33							
47							
68							
100							
150							
220							
330							
470							
680							
1000							
1500							
3300							
4700							
10000							
22000							
47000							
100000							
150000							

Safety Chip Capacitors



MSC Series
(X2/Y3)

MERITEK

SPECIFICATIONS

UL No. E197475

CODE	NPO	X7R
Temperature Characteristics	0 ±30ppm/°C	ΔC ±15% (-55°C to +125°C)
Dissipation Factor (D.F.)	0.15% max. (+25°C, 1Vrms, 1MHz)	2.5% max. (+25°C, 1Vrms, 1 KHz)
Insulation Resistance	100000MΩ or 1000MΩ • μF whichever is less	100000MΩ or 1000MΩ • μF whichever is less
Dielectric Withstanding Voltage	120% rated voltage, 25°C, 5 sec.	120% rated voltage, 25°C, 5 sec.
Standard Tolerance	J (±5%), K (±10%), M (±20%)	J (±5%), K (±10%), M (±20%)

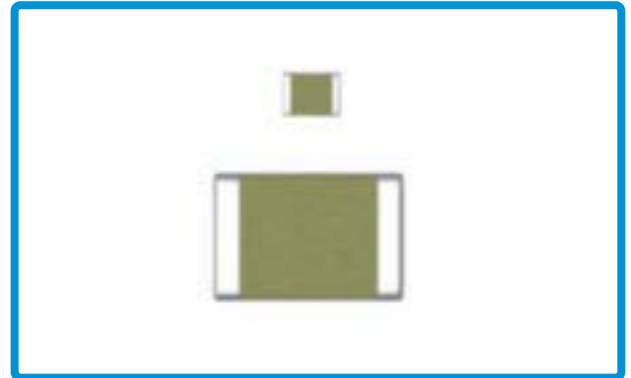

MERITEK MSC series safety Chip Capacitors are designed for surge or lightning protection in across the line and line bypass applications, such as telephone, computer network, modem, and other electronic equipments.

PART NUMBERING SYSTEM

	MSC	1808	XR	101	K	3K
Meritek Series						
Size						
Dielectric						
CODE	CG	XR				
	COG (NPO)	X7R				
Capacitance						
CODE	8R2	101	102	152		
pF	8.2	100	1000	1500		
nF	--	.1	1	1.5		
μF	--	0.0001	0.001	0.0015		
Tolerance						
Code	Tolerance	Code	Tolerance	Code	Tolerance	
F	±1%	G	±2%	J	±5%	
K	±10%	M	±20%	Z	+80/-20%	
Rated Voltage						
Code	3K					
R.V.	3KVdc/250Vab					

Capacitance Range

Material	NP0	X7R
Voltage	3KVdc/250Vac	3KVdc/250Vac
E12 series	1808	1808
5pF		
10pF		
12pF		
15pF		
18pF		
22pF		
27pF		
33pF		
39pF		
47pF		
56pF		
68pF		
82pF		
100pF		
120pF		
150pF		
180pF		
220pF		
270pF		
330pF		
390pF		
470pF		
560pF		
680pF		
820pF		
1.0nF		
1.2nF		
1.5nF		
1.8nF		
2.2nF		
2.7nF		
3.3nF		
3.9nF		

Thickness:  1.60±0.2mm
 2.00±0.2mm

Dimensions

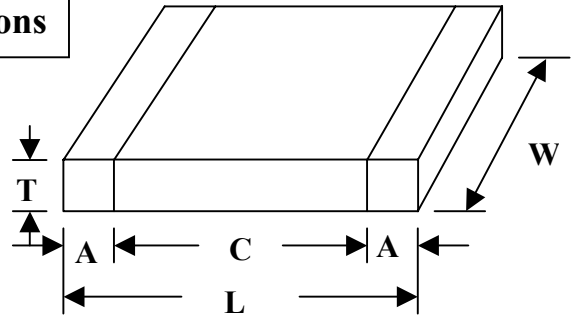

Product dimensions in mm.

Case size	Length (L)	Width (W)	Thickness (T)	Termination length (A)	Distance between terminations (C)
1808	4.6±0.30	2.00±0.30	2.00±0.20	0.30 min.	3.2 min.

Tape and Reel

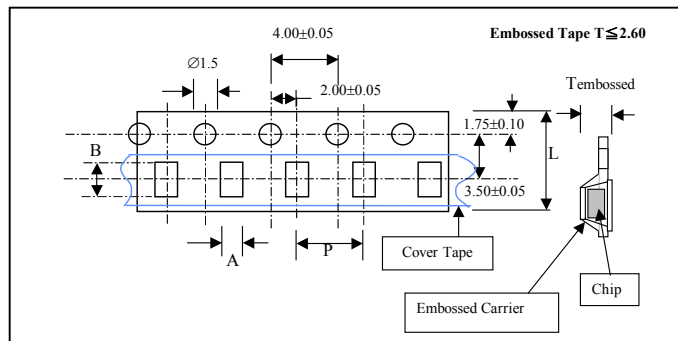

Size	Symbol				
	A	B	P	L	T(Embossed)
1808	2.50±0.30	4.90±0.30	4.00±0.10	12.0±0.20	Max.2.6

All dimensions in mm

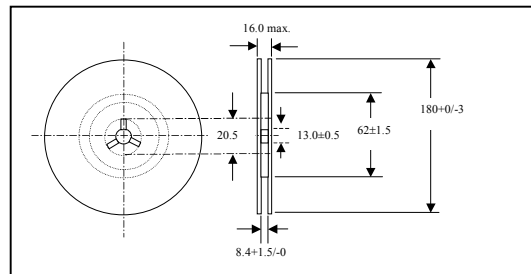

All dimensions in mm

Standard Packing Quality per Reel

Product Thickness	Embossed Taping
1.60±0.2 mm	2000 pcs
2.00±0.2 mm	1000pcs

PACKAGING

1. Tape and Reel Package

Taping is in accordance with EIA RS-481 or IEC 286-3

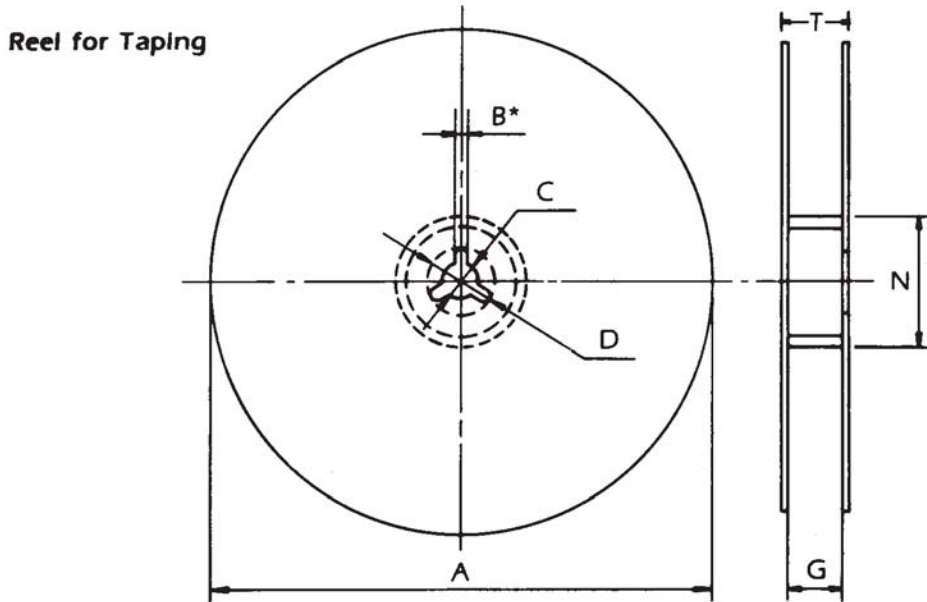

Unit: mm

Symbol	A	N	C	D	B*	G	T
Dimension	178 ± 2.0	50 min.	13.0 ± 0.5	20 min	2.0	10.0 ± 1.5	14.9 max.

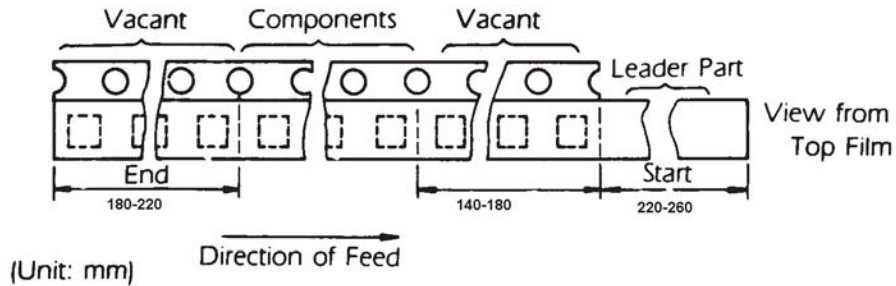

Note: 13" reel available upon request.

1. CARDBOARD TAPE DIMENSIONS

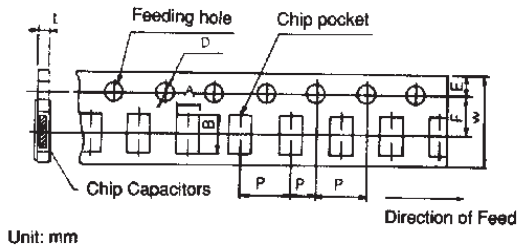

2. EMBOSSED TAPE DIMENSIONS

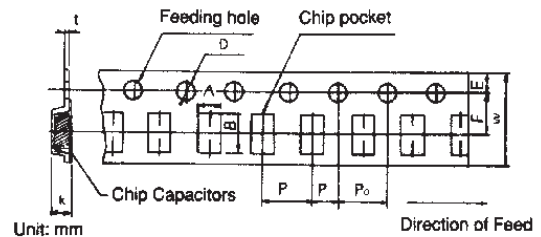

CARDBOARD TAPE

Unit: mm

SYMBOL	A	B	W	F	E	P ₁	P ₂	P ₀	f D	t ₁
0603	1.25 ±0.2	2.05 ±0.2	8.0 ±0.2	3.5 ±0.05	1.75 ±0.1	4.0 ±0.1	2.0 ±0.05	4.0 ±0.1	1.5 +0.1/-0	1.1 max
0805	1.65 ±0.2	2.4 ±0.2								
1206	2.0 ±0.2	3.6 ±0.2								

EMBOSSSED TAPE

Unit: mm

SYMBOL	A	B	W	F	E	P ₁	P ₂	P ₀	fD	t ₁	K
0603	1.6 ±0.2	2.4 ±0.2	8.0 ±0.2	3.5 ±0.05	1.75 ±0.1	4.0 ±0.1	2.0 ±0.05	4.0 ±0.1	1.5 +0.1/-0	0.3 max	2.0 max
0805	1.95 ±0.2	3.6 ±0.2									
1206	2.8 ±0.2	3.7 ±0.2									
1812	3.6 ±0.2	4.9 ±0.2	1.20 ±0.3	5.5 ±0.1	1.75 ±0.1	8.0 ±0.1	2.0 ±0.1	8.0 ±0.1	1.5 +0.1/-0	0.3 max	2.5 max

Standard tape for 0805 and 1206 sizes is cardboard tape.

Embossed tape is only available upon special request.

Standard Package Quantity Per Reel

CHIP SIZE	CHIP THICKNESS MAX	CARDBOARD TAPE	EMBOSSSED TAPE
0402	0.6	10,000	-
0603	1.0	4,000	-
0805			
1206			
1210	1.30	-	3,000
1812	1.30	-	1,500