

RoHS Compliant

Features

- Reduction in mounting costs & Process
- Save PCB space
- Eight resistors in one SMD package
- Reduction of inventory control costs

Applications

- Lap Top Computer
- Notebook Computer
- Printer
- Hard Disk Drive
- CD ROM
- Facsimile

How to Order

RNA4A 8E 103 J U
 ① ② ③ ④ ⑤

- ① Series
- ② Number of elements (8E: 8 elements)
- ③ Resistance code (3 digits)
- ④ Resistance tolerance (J: ±5%)
- ⑤ Packaging

U Plastic Taping, 4,000 pcs./ reel

* Taping Qty.: 4000 pcs./ 7 inch reel (4mm pitch)
 Carrier Tape: plastic

Shape and Dimensions

(Unit: mm)

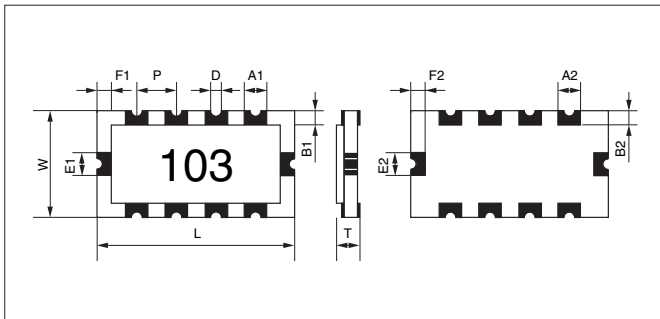

Code	L	W	T	A1	B1
Dimensions	4.0±0.15	2.1±0.15	0.6±0.1	0.5±0.1	0.25±0.15
Code	E1	F1	D	P	A2
Dimensions	0.5±0.1	0.3±0.15	0.3 typ.	0.8 typ.	0.4±0.1
Code	B2	E2	F2		
Dimensions	0.4±0.15	0.5±0.1	0.35±0.15		

Circuit Diagram

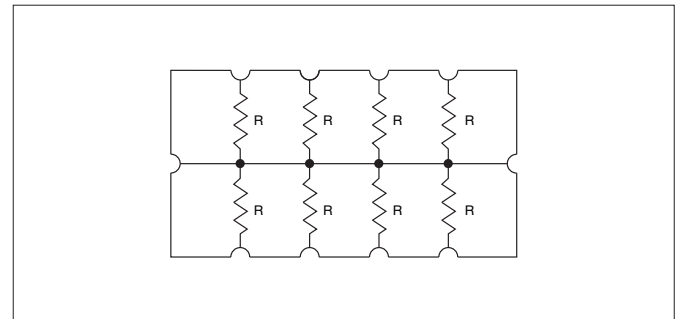

• Nominal resistance value is all the same.

Specifications

Item	Rating
Rated power (70°C)	1/ 16W (0.0625W)/ Element
Max. working voltage*	25V
Max. over-load voltage	50V
Resistance value	100Ω to 220KΩ
Tolerance	J: ±5%
Number of elements	8E: 8 elements
Working temperature	-55 to +125°C

* Rated Voltage: $\sqrt{\text{Rated power} \times \text{Resistance value}}$, whichever is less.

* Standard Resistance Value: E-6 Series

* If resistance value under 100Ω is needed, please contact sales.

Recommended Land Patterns

Chip Type

(Unit: mm)

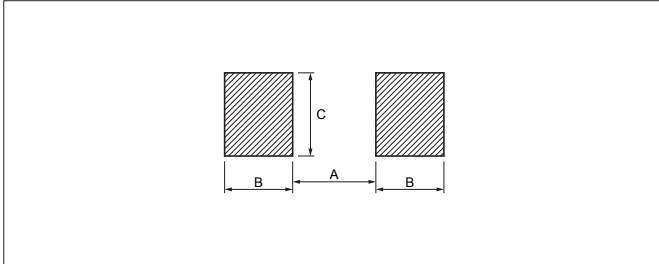

EIA Size	A	B	C
0805	1.0	0.8	1.2
1206	2.2	0.9	1.5
1020	1.4	1.0	5.0
2512	5.0	1.0	3.0

Array Type

(Unit: mm)

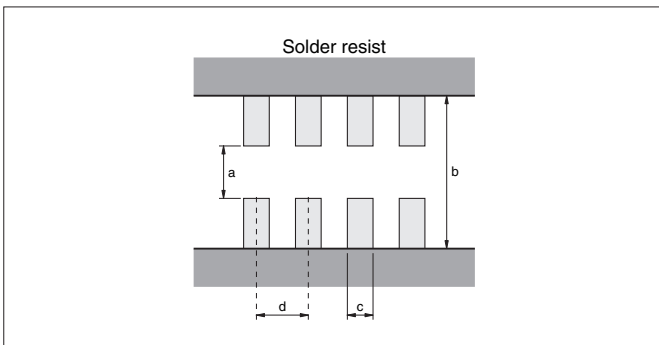

Series	a	b	c	d
CRB2A4E	0.4	1.5	0.25	0.5
CRC11A2E	0.5	1.5	0.4	0.65
CRC4A8E	0.8	2.4	0.3	0.5
CRB6A8E	0.7	2.3	0.4	0.8
ATC1A	0.5	1.5	0.4	0.65

(Unit: mm)

CRC2A4E Series

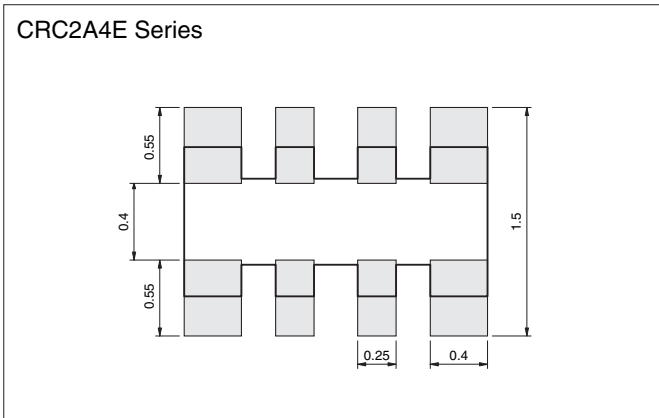

(Unit: mm)

RNA4A8E Series

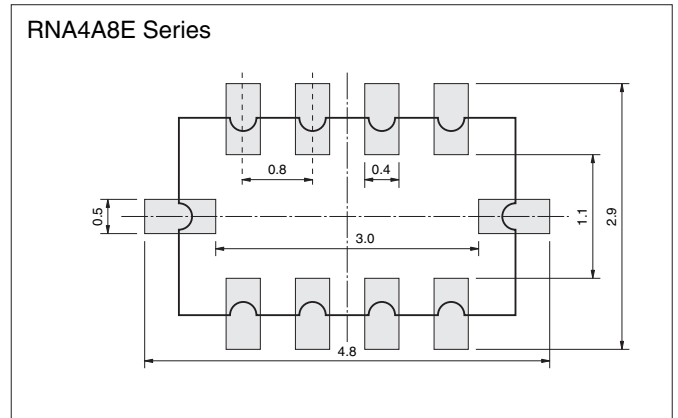

Circuit design

- 1) Once application and assembly environments have been checked, the resistors may be used in conformance with the catalog and the specifications.
- 2) Please consult the manufacturer in advance when the resistors is used in devices such as: devices which deal with human life, i.e. medical devices; devices which are highly public orientated; and devices which demand a high standard of liability.
- 3) Please use the resistors in conformance with the operating temperature provided in both the catalog and the specifications.
- 4) Please keep voltage under the rated voltage which is applied to the resistor.
- 5) Do not use the resistor in an environment where it might easily exceed the respective provisions concerning shock and vibration specified in the catalog and specifications.
- 6) Please do not use the resistor in the following environments.
 - ① State that water, oil, and solvent hang in resistor
 - ② State where poisonous gas (sulfur and chlorine, etc.) exists
 - ③ State that direct sunshine, radiation, and ultraviolet, etc. are irradiated
- 7) There is a thing that resistance changes according to the stuff of the resin when the coating with the resin is given. Please use resin coating after confirming the characteristic.
- 8) There is a thing that resistance changes according to flux and cleaner. Please use flux and cleaner after confirming the characteristic.
- 9) Please consult about a lead free products.

Storage

- 1) Keep storage place temperature +5 to +35°C, humidity 45 to 75% RH.
- 2) Please keep parts out of poisonous gas such as sulfur or chlorine in the air and out of salty moisture, or they may cause rust of terminal and poor solderability. Please consider the above-mentioned item after mounting.
- 3) Soldering iron

Temperature	soldering iron 300±5°C *
Time	3 sec. max. *

*Do not place the soldering iron on the chip. Soldering iron is 30W max.

Soldering method

1) Recommendable temperature profile

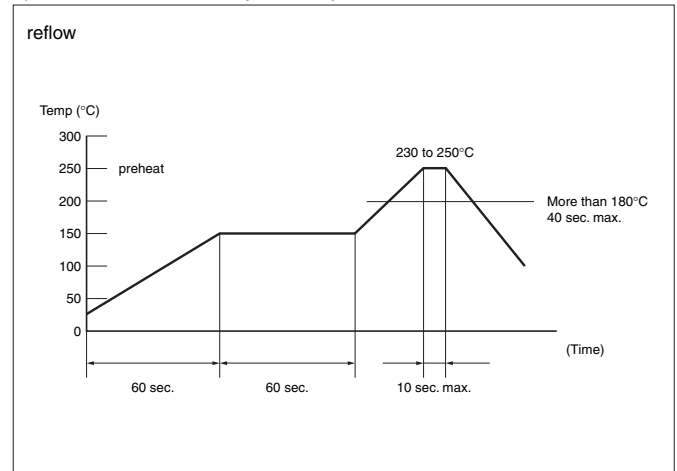

2) Recommendable temperature profile

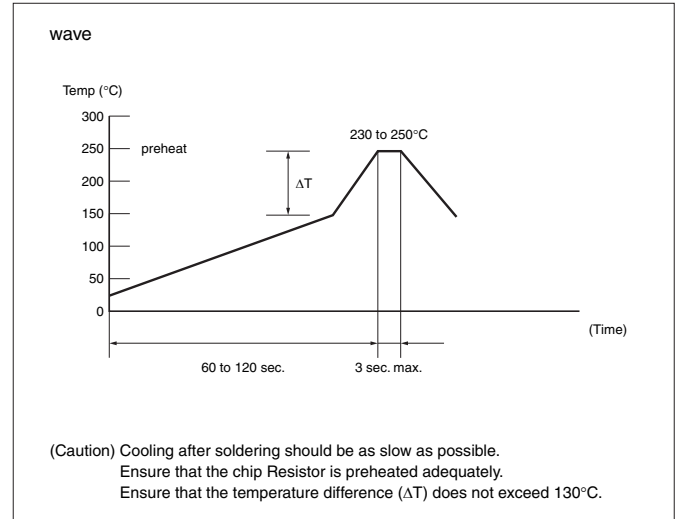

3) Pb-free recommendable temperature profile

