

### features

- Available in various types of standard circuits in different sizes and power
- Higher temperature soldering of the leads prevents terminals from loosening during board assembly
- For automatic insertion machines, stick magazines and taping packages are available
- Marking: Black body color with white marking
- Products with lead-free terminations meet RoHS requirements. Pb located in glass material, electrode and resistor element is exempt per Annex 1, exemption 5 of EU directive 2005/95/EC

### dimensions and construction

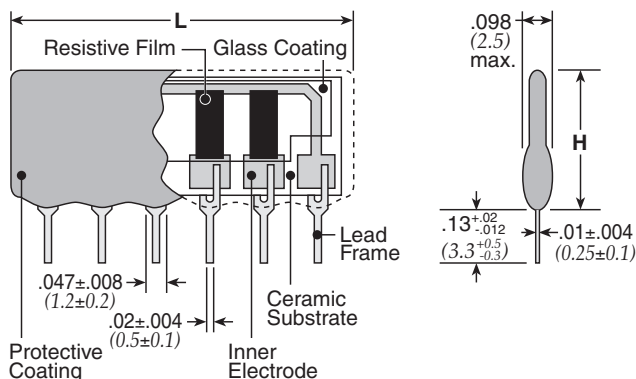

Type	Number of Pins (P)	Dimensions inches (mm)	
		L (max.)	H
RKC	3 - 16	.100 x P + .024 (2.54 x P + 0.6)	.256 (6.5)
RKH	4 - 13		.421 (10.7)
RKL	4 - 12	.100 x P (2.54 x P)	.200 (5.08)
	3	.100 x P + .024 (2.54 x P + 0.6)	

### ordering information

New Part #	RKC	8	B	D	STP	103	F
Type	RKC RKH RKL	Number of Resistors	Circuit Symbol	Termination Material	Packaging	Nominal Resistance	Tolerance
		3 - 16	B, S, C, D, A, T, E, R, L, K	D: SnAgCu (Other termination styles available, contact factory for options)	STP, STB, TBA, TPA, TUA	2 significant figures + 1 multiplier for ±2% & ±5% 3 significant figures + 1 multiplier for ±1%	F: ±1% G: ±2% J: ±5%

For further information on packaging, please refer to Appendix C.

### circuit schematics

**B circuit**

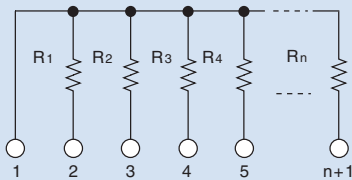

$R1=R2=R3=R4=...=Rn$   
n: number of elements  
Example: RKC8B 103 J  
RKL8B 472 J  
RKH8B 332 J

**S circuit**

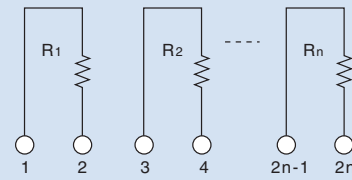

$R1=R2=...=Rn$   
n: number of elements  
Example: RKC4S 103 J  
RKL4S 472 J  
RKH4S 332 J

**C circuit**

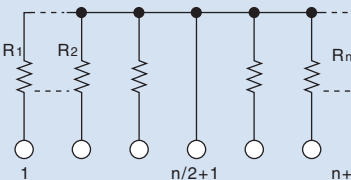

$R1=R2=R3=R4=...=Rn$   
n: number of elements  
Example: RKC8C 103 J  
RKL8C 472 J  
RKH8C 332 J

**D circuit**

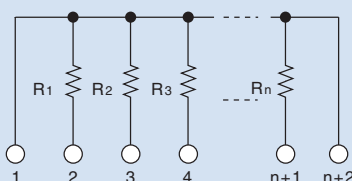

$R1=R2=R3=...=Rn$   
n: number of elements  
Example: RKC8D 103 J  
RKL8D 472 J  
RKH8D 332 J

**A circuit**

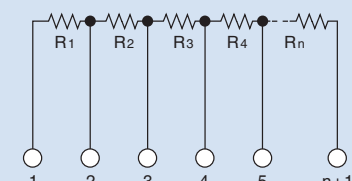

$R1=R2=R3=R4=...=Rn$   
n: number of elements  
Example: RKC8A 103 J  
RKL8A 472 J  
RKH8A 332 J

**T circuit**

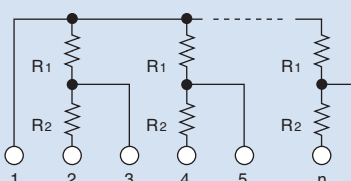

$R1=R2$  or  $R1 \neq R2$   
n: number of elements  
Example: RKC8T 103/103 J  
RKL8T 103/103 J  
RKH8T 103/103 J

**E circuit**

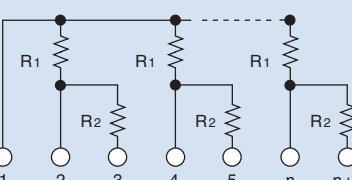

$R1=R2$  or  $R1 \neq R2$   
n: number of elements  
Example: RKC8E 103/103 J  
RKL8E 103/103 J  
RKH8E 103/103 J

**R circuit**

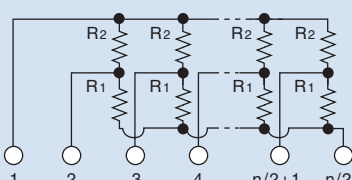

$R1=R2$  or  $R1 \neq R2$   
n: number of elements  
Example: RKC16R 331/471 J  
RKL16R 331/471 J  
RKH16R 331/471 J

**L circuit**

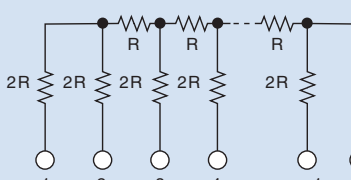

n: number of elements  
Example: RKC5L 253

**K circuit**

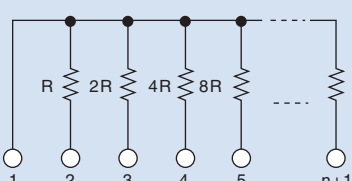

n: number of elements  
Example: RKC4K 102

**Example of custom circuit**

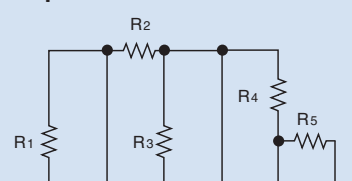

**Example of custom circuit**

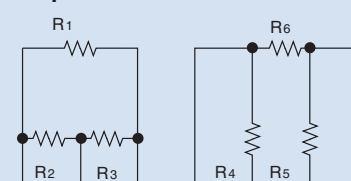

### applications and ratings

Part Designation	Characteristics Circuit Configuration	Per Resistor	Ratings													
			Max. Power (mW) Per Package @ 70°C													
			3 pin	4 pin	5 pin	6 pin	7 pin	8 pin	9 pin	10 pin	11 pin	12 pin	13 pin	14 pin	15 pin	16 pin
RKC	Bn nA nR	125	250	375	500	625	750	875	1000	1050	1150	1250	1350	1450	1500	1550
	BnD		—	—	375	500	625	750	875	1000	1125	1250	1350	1450	1500	1550
	BnC nT nE		—	—	500	—	750	—	1000	—	1150	—	1350	—	1500	—
	BnS	250	—	500	—	750	—	1000	—	1050	—	1250	—	1450	—	1550
RKH	Bn	250	—	525	700	875	1050	1250	1400	1500	1600	1700	1800	—	—	—
	nA nR		—	—	700	875	1050	1250	1400	1500	1600	1700	1800	—	—	—
	BnD		—	—	700	875	1050	1250	1400	1500	1600	1700	1800	—	—	—
	BnC nT nE		—	—	700	—	1050	—	1400	—	1600	—	1800	—	—	—
	BnS	500	—	700	—	1050	—	1400	—	1500	—	1700	—	—	—	—
RKL	Bn nA nR	125	220	330	440	510	570	610	660	700	740	780	—	—	—	—
	BnD		—	250	375	500	570	610	660	700	740	780	—	—	—	—
	BnC nT nE		—	—	440	—	570	—	660	—	740	—	—	—	—	—
	BnS	200	—	330	—	510	—	610	—	700	—	780	—	—	—	—

Part Designation	Resistance Range	R circuit (E-24)*	Others (E-24)	L circuit	K circuit	Operating Temp. Range	L & K Circuit	Others	
		100Ω - 100KΩ	22Ω - 2.2MΩ	2.5kΩ, 5kΩ, 10kΩ, 25kΩ, 50kΩ, 100kΩ	R1(MSB): 100Ω Min. Rn(LSB): 1MΩ Max.	-55°C to +125°C	-55°C to +155°C		
RKC	T.C.R.	±200ppm/°C is standard				Rating Ambient Temp.	+70°C		
	Resistance Tolerance	Others		L circuit (BIT ERROR)	K circuit (BIT ERROR)				
		G±2%, J±5%	F±1%*, G±2%, J±5%	±1/2 LSB	±1/2 LSB				
	Wattage Per Element	S circuit 250mW	Others 125mW	L circuit 20mW	K circuit 40mW				

\* R circuit is not available in ±1% tolerance.

Part Designation	Resistance Range	R circuit*	Others	Operating Temp. Range
		100Ω - 100KΩ	56Ω - 2.2MΩ	-55°C to +155°C
RKH	T.C.R.	±200ppm/°C		Max. Working Voltage
				250V
	Resistance Tolerance	G±2%, J±5%	F±1%*, G±2%, J±5%	Rating Ambient Temp.
				+70°C
	Wattage Per Element	S circuit 500mW	Others 250mW	

\* R circuit is not available in ±1% tolerance.

Part Designation	Resistance Range	R circuit*	Others	Operating Temp. Range
		100Ω - 100KΩ	22Ω - 1.0MΩ	-55°C to +125°C
RKL	T.C.R.	±200		Max. Working Voltage
				100V
	Resistance Tolerance	G±2%, J±5%	F±1%*, G±2%, J±5%	Rating Ambient Temp.
				+70°C
	Wattage Per Element	S circuit 200mW	Others 125mW	

\* R circuit is not available in ±1% tolerance.

### applications and ratings (continued)

Part Designation	Resistance Range	All	Operating Temp. Range	-55°C to +125°C
			10Ω - 1MΩ	
M-	T.C.R.	±100, ±150, ±200	Max. Working Voltage	RKC (1.8 pitch): 50V, RKL & RKS (2.0 pitch): 100V, RKC (2.54 pitch): 200V, RKH: 250V
	Resistance Tolerance	±0.5%, ±1%, ±2%, ±5%	Rating Ambient Temp.	+70°C
	Wattage Per Element	0.1W, 0.125W, 0.25W, 0.5W, 1W		

### environmental applications

#### Derating Curve

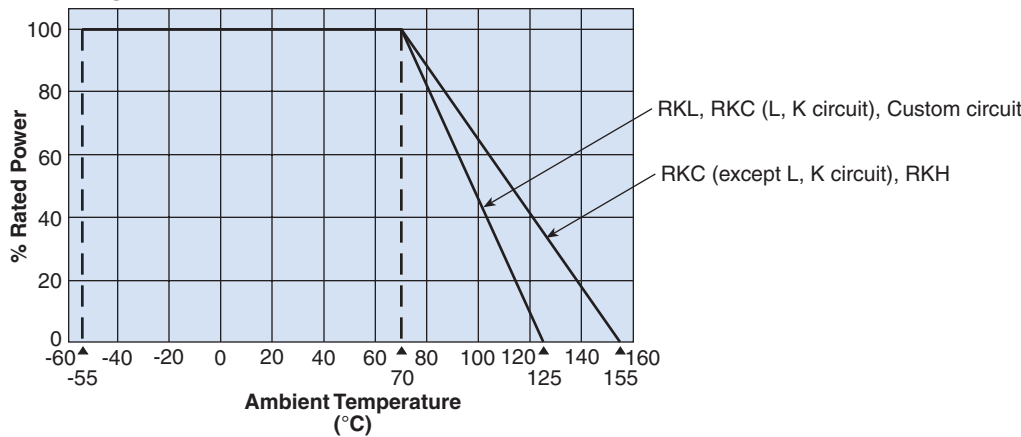

### Performance Characteristics

Parameter	Requirement	Test Method MIL-STD-202
Temperature Coefficient	±200ppm/°C (std.)	304 (Operating Temperature Range)
Short Time Overload	±(0.5% + 0.05Ω)	(MIL R 83401 3.14)
Insulation Resistance	Over 10 <sup>11</sup> MΩ	302A
Dielectric Withstanding Voltage	±(0.5% + 0.05Ω)	301, 200V (AC), 60 seconds
Terminal Strength Pull Test		211A, Condition A, 2 lbs.
Terminal Strength Bend Test	3 cycles and over	211A, Condition B
Resistance to Solder Heat	±(0.5% + 0.05Ω)	210A, Condition B
Solderability	95% minimum	208E
Life (at elevated ambient temp.)	±3%	108A, 1000 hours
Temperature Cycling	±(0.5% + 0.05Ω)	107D, -40°C to +85°C
Moisture Endurance	±1% + 0.05Ω < 100K ≥ ±2%	103B, 40°C, 95% RH, 1000 hours
Rated Load Endurance		108A, 70°C, 1000 hours