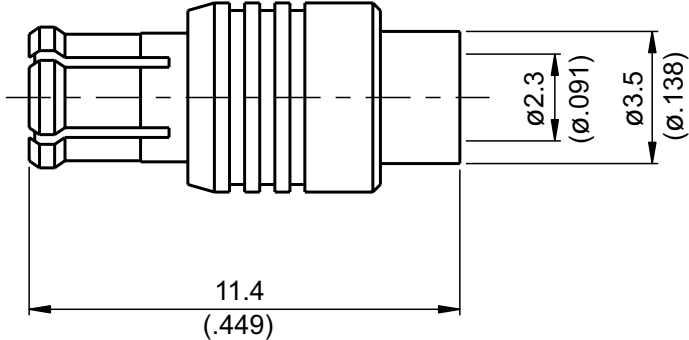

MCX3300-0085	MCX Plug Solder For RG405 6GHz VSWR 1.25	<b>50Ω</b>
		
Parts	Material	Plating (Micro-inch)
Contact Pin	Brass	Gold 4 Over Nickel-Phosphorus Alloy 80 Over Copper 20
Insulator	Teflon	
Body	Phosphor Bronze	Gold 4 Over Nickel-Phosphorus Alloy 80 Over Copper 20
<p>Weight: 0.76 g Suitable Cables: Semi-rigid.085, Conformable .085</p>		

This part number complies with RoHS.

Notice: JYEBAO reserves the right to make modifications deemed appropriate.

MCX	MCX3300-0085																		
<div data-bbox="167 344 568 394" style="border: 1px solid black; padding: 2px;">Interface</div> <p data-bbox="167 400 367 434">IEC 61169-36</p>																			
<div data-bbox="167 510 568 560" style="border: 1px solid black; padding: 2px;">Electrical Data</div> <table data-bbox="167 566 1340 981"> <tr> <td>Impedance</td> <td>50Ω</td> </tr> <tr> <td>Frequency range</td> <td>DC to 6GHz</td> </tr> <tr> <td>VSWR</td> <td>≤ 1.25 (DC to 6GHz)</td> </tr> <tr> <td>Insertion loss</td> <td>≤ 0.1dB to 1GHz; ≤ 0.15 to 3GHz</td> </tr> <tr> <td>Insulation resistance</td> <td>≥ 10000MΩ</td> </tr> <tr> <td>Contact resistance inner conductor</td> <td>≤ 5mΩ</td> </tr> <tr> <td>Contact resistance outer conductor</td> <td>≤ 2.5mΩ</td> </tr> <tr> <td>Dielectric withstanding voltage (at sea level)</td> <td>750 V rms</td> </tr> <tr> <td>Working voltage (at sea level)</td> <td>250 V rms</td> </tr> </table>		Impedance	50Ω	Frequency range	DC to 6GHz	VSWR	≤ 1.25 (DC to 6GHz)	Insertion loss	≤ 0.1dB to 1GHz; ≤ 0.15 to 3GHz	Insulation resistance	≥ 10000MΩ	Contact resistance inner conductor	≤ 5mΩ	Contact resistance outer conductor	≤ 2.5mΩ	Dielectric withstanding voltage (at sea level)	750 V rms	Working voltage (at sea level)	250 V rms
Impedance	50Ω																		
Frequency range	DC to 6GHz																		
VSWR	≤ 1.25 (DC to 6GHz)																		
Insertion loss	≤ 0.1dB to 1GHz; ≤ 0.15 to 3GHz																		
Insulation resistance	≥ 10000MΩ																		
Contact resistance inner conductor	≤ 5mΩ																		
Contact resistance outer conductor	≤ 2.5mΩ																		
Dielectric withstanding voltage (at sea level)	750 V rms																		
Working voltage (at sea level)	250 V rms																		
<div data-bbox="167 1052 568 1102" style="border: 1px solid black; padding: 2px;">Mechanical Data</div> <table data-bbox="167 1108 1037 1288"> <tr> <td>Engagement force</td> <td>≤ 5.6 lbs</td> </tr> <tr> <td>Disengagement force</td> <td>1.8 to 4.5 lbs</td> </tr> <tr> <td>Contact captivation-axial</td> <td>≥ 2.3 lbs</td> </tr> <tr> <td>Durability (mating)</td> <td>≥ 500</td> </tr> </table>		Engagement force	≤ 5.6 lbs	Disengagement force	1.8 to 4.5 lbs	Contact captivation-axial	≥ 2.3 lbs	Durability (mating)	≥ 500										
Engagement force	≤ 5.6 lbs																		
Disengagement force	1.8 to 4.5 lbs																		
Contact captivation-axial	≥ 2.3 lbs																		
Durability (mating)	≥ 500																		
<div data-bbox="167 1361 568 1411" style="border: 1px solid black; padding: 2px;">Environmental Data</div> <table data-bbox="167 1417 1420 1641"> <tr> <td>Temperature range</td> <td>-55°C to +155°C</td> </tr> <tr> <td>Thermal shock</td> <td>MIL-STD-202, Method 107, Condition B</td> </tr> <tr> <td>Moisture resistance</td> <td>MIL-STD-202, Method 106</td> </tr> <tr> <td>Corrosion</td> <td>MIL-STD-202, Method 101, Condition B</td> </tr> <tr> <td>RoHS</td> <td>Compliant</td> </tr> </table>		Temperature range	-55°C to +155°C	Thermal shock	MIL-STD-202, Method 107, Condition B	Moisture resistance	MIL-STD-202, Method 106	Corrosion	MIL-STD-202, Method 101, Condition B	RoHS	Compliant								
Temperature range	-55°C to +155°C																		
Thermal shock	MIL-STD-202, Method 107, Condition B																		
Moisture resistance	MIL-STD-202, Method 106																		
Corrosion	MIL-STD-202, Method 101, Condition B																		
RoHS	Compliant																		
<div data-bbox="167 1713 568 1762" style="border: 1px solid black; padding: 2px;">Tooling</div> <table data-bbox="167 1769 790 1948"> <tr> <td>Soldering gauge</td> <td>ST-0.2</td> </tr> <tr> <td>Soldering fixture</td> <td>ST-008</td> </tr> <tr> <td>Insert for .085 semi-rigid cable</td> <td>ST-009</td> </tr> <tr> <td>Locator tool</td> <td>ST-011</td> </tr> </table>		Soldering gauge	ST-0.2	Soldering fixture	ST-008	Insert for .085 semi-rigid cable	ST-009	Locator tool	ST-011										
Soldering gauge	ST-0.2																		
Soldering fixture	ST-008																		
Insert for .085 semi-rigid cable	ST-009																		
Locator tool	ST-011																		

Notice: JYEBAO reserves the right to make modifications deemed appropriate.

# JYE BAO CO., LTD.

## CABLE ASSEMBLY INSTRUCTION

MCX3300-0085	DATE	2020/04/24	REV	A
--------------	------	------------	-----	---

<p>A</p>  <p>BODY</p>	<p>B</p>  <p>CONTACT PIN</p>
--	--

DIAGRAM	ASSEMBLY INSTRUCTION
---------	----------------------

	<p>Step 1: STRIP AS SHOWN.</p>
--	--------------------------------

	<p>Step 2: PUT PIN " B " ON CENTER CONDUCTOR AND SOLDER IN " Y ". USE GAUGE ST-0.2.</p>
---	---

	<p>Step 3: USE SOLDERING FIXTURE " ST-008 " , INSERT TOOL " ST-009 " AND LOCATOR TOOL " ST-011 " TO FIX THE CONNECTOR. SOLDER IN " X ".</p>
---	---

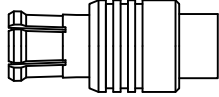
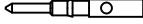
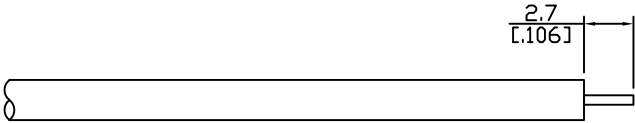
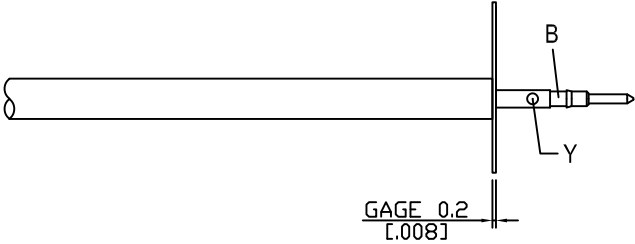
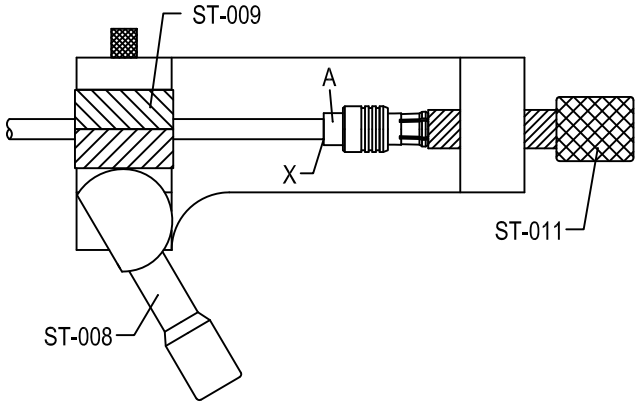
This part number complies with RoHS.  
 Notice: JYEBAO reserves the right to make modifications deemed appropriate.

APPROVED	CHECKED	DRAWING
----------	---------	---------

*Albert*

# MCX3300-0085

S11

