



ICS525-01/02 OSCaR™ User Configurable Clock

Description

The ICS525-01 and ICS525-02 are the most flexible way to generate a high quality, high accuracy, high frequency clock output from an inexpensive crystal or clock input. The name OSCaR stands for OSCillator Replacement, as they are designed to replace crystal oscillators in almost any electronic system. The user can configure the device to produce nearly any output frequency from any input frequency by grounding or floating the select pins. Neither microcontroller, software, nor device programmer are needed to set the frequency. Using Phase-Locked-Loop (PLL) techniques, the device accepts a standard fundamental mode, inexpensive crystal to produce output clocks up to 250 MHz. It can also produce a highly accurate output clock from a given input clock, keeping them frequency locked together.

For similar capability with a serial interface, use the ICS307. For simple multipliers to produce common frequencies, refer to the LOCO family of parts, which are smaller and more cost effective.

This product is intended for clock generation. It has low output jitter (variation in the output period), but input to output skew and jitter are not defined nor guaranteed. For applications which require defined input to output timing, use the ICS527-01.

Features

- Packaged as 28 pin SSOP (150 mil body)
- ICS525-01 with output frequencies up to 160 MHz
- ICS525-02 with output frequencies up to 250 MHz
- User determines the output frequency by setting all internal dividers
- Eliminates need for custom oscillators
- No software needed
- Online ICS525 calculator at www.icst.com/products/ics525inputForm.html
- Pull-ups on all select inputs
- Input crystal frequency of 5 - 27 MHz
- Input clock frequency of 2 - 50 MHz
- Very low jitter
- Duty cycle of 45/55 up to 200 MHz
- Operating voltages of 3.0 to 5.5V
- Ideal for oscillator replacement
- Industrial temperature versions available
- For Zero Delay, refer to the ICS527

Block Diagram

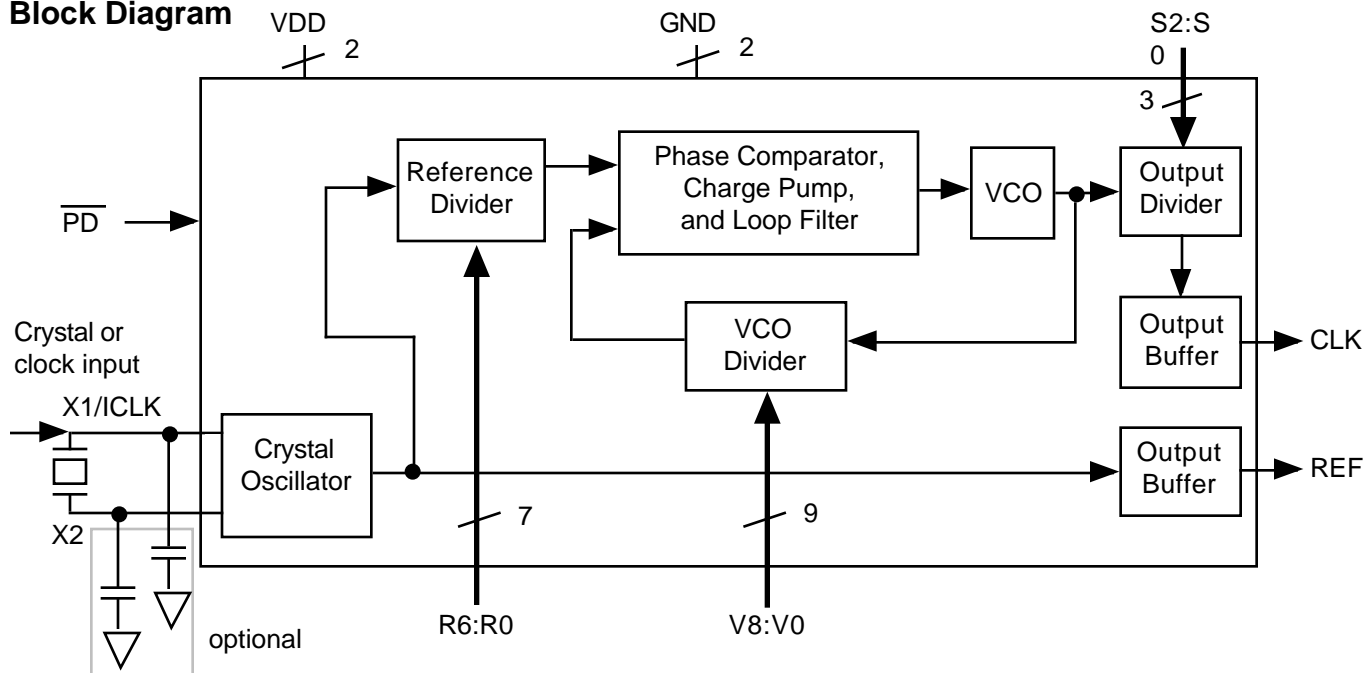



ICS525-01/02

OSCaR™ User Configurable Clock

Pin Assignments

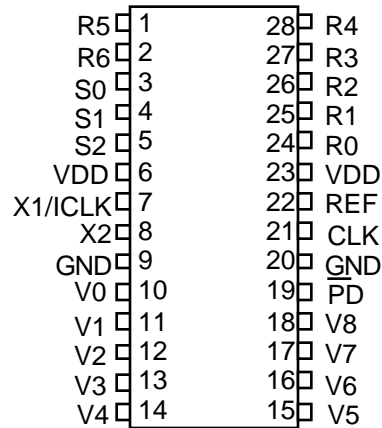

ICS525-01

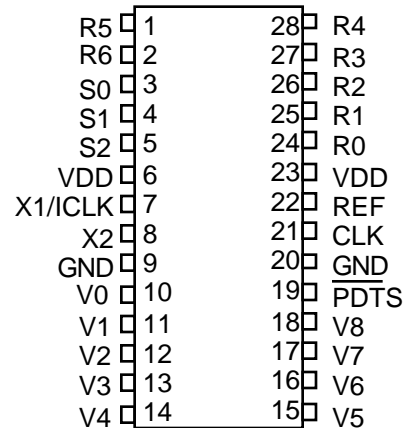

ICS525-02

ICS525-01 Pin Descriptions

Pin #	Name	Type	Description
1, 2, 24-28	R5, R6, R0-R4	I(PU)	Reference divider word input pins determined by user. Forms a binary number from 0 to 127.
3, 4, 5	S0, S1, S2	I(PU)	Select pins for output divider determined by user. See table on page 3.
6, 23	VDD	P	Connect to VDD.
7	X1/ICLK	X1	Crystal connection. Connect to a parallel resonant fundamental crystal, or input clock.
8	X2	X2	Crystal connection. Connect to a crystal, or leave unconnected for clock.
9, 20	GND	P	Connect to ground.
10-18	V0-V8	I(PU)	VCO divider word input pins determined by user. Forms a binary number from 0 to 511.
19	$\overline{\text{PD}}$	I(PU)	Power Down. Active low. Turns off entire chip when low. Clock outputs stop low.
21	CLK	O	Output Clock determined by status of R0-R6, V0-V8, S0-S2 and input frequency.
22	REF	O	Reference output. Buffered crystal oscillator (or clock) output.

ICS525-02 Pin Descriptions

Pin #	Name	Type	Description
1, 2, 24-28	R5, R6, R0-R4	I(PU)	Reference divider word input pins determined by user. Forms a binary number from 0 to 127.
3, 4, 5	S0, S1, S2	I(PU)	Select pins for output divider determined by user. See table on page 3.
6, 23	VDD	P	Connect to VDD.
7	X1/ICLK	X1	Crystal connection. Connect to a parallel resonant fundamental crystal, or input clock.
8	X2	X2	Crystal connection. Connect to a crystal, or leave unconnected for clock.
9, 20	GND	P	Connect to ground.
10-18	V0-V8	I(PU)	VCO divider word input pins determined by user. Forms a binary number from 0 to 511.
19	$\overline{\text{PDTs}}$	I(PU)	Power Down and Tri-state. Active low. Turns off entire chip and tri-states the outputs when low.
21	CLK	O	Output Clock determined by status of R0-R6, V0-V8, S0-S2 and input frequency.
22	REF	O	Reference output. Buffered crystal oscillator (or clock) output.

Key: I(PU) = Input with internal pull-up resistor; X1, X2 = Crystal connections; O = Output;
P = Power supply connection



ICS525-01/02 OSCaR™ User Configurable Clock

ICS525-01 Output Divider and Maximum Output Frequency Table

S2 pin 5	S1 pin 4	S0 pin 3	CLK Output Divider	Max. Output Frequency (MHz)			
				VDD = 5 V		VDD = 3.3V	
				0-70 °C	-40 to +85 °C	0-70 °C	-40 to +85 °C
0	0	0	10	26	23	18	16
0	0	1	2	160	140	100	90
0	1	0	8	40	36	25	22
0	1	1	4	80	72	50	45
1	0	0	5	50	45	34	30
1	0	1	7	40	36	26	23
1	1	0	9	33.3	30	20	18
1	1	1	6	53	47	27	24

ICS525-02 Output Divider and Maximum Output Frequency Table

S2 pin 5	S1 pin 4	S0 pin 3	CLK Output Divider	Max. Output Frequency (MHz)	
				VDD = 5V	VDD = 3.3V
				-40 to +85 °C	-40 to +85 °C
0	0	0	6	67	40
0	0	1	2	200	120
0	1	0	8	50	30
0	1	1	4	100	60
1	0	0	5	80	48
1	0	1	7	57	34
1	1	0	1	250	200
1	1	1	3	133	80

The ICS525-02 is only offered in the industrial temperature range.

External Components / Crystal Selection

The ICS525 requires two 0.01µF decoupling capacitors to be connected between VDD and GND, one on each side of the chip. They must be connected close to the ICS525 to minimize lead inductance. No external power supply filtering is required for this device. A 33 series terminating resistor can be used next to the CLK and REF pins. The approximate total on-chip capacitance for a crystal is 16pF, so a parallel resonant, fundamental mode crystal with this value of load (correlation) capacitance should be used. For example, using the ICS525-01 with crystals having a specified load capacitance greater than 16 pF, crystal capacitors may be connected from each of the pins X1 and X2 to Ground as shown in the Block Diagram on page 1. The value (in pF) of these crystal caps should be = $(C_L - 16) * 2$, where C_L is the crystal load capacitance in pF. These external capacitors are only required for applications where the exact frequency is critical. For a clock input, connect to X1 and leave X2 unconnected (no capacitors on either).



Determining (setting) the output frequency

The user has full control in setting the desired output frequency over the range shown in the table on page 2. To replace a standard oscillator, a user should connect the divider select input pins directly to ground (or VDD, although this is not required because of internal pull-ups) during Printed Circuit Board layout, so that the ICS525 automatically produces the correct clock when all components are soldered. It is also possible to connect the inputs to parallel I/O ports to switch frequencies. By choosing dividers carefully, the number of inputs which need to be changed can be minimized. Observe the restrictions stated below on allowed values of VDW and RDW.

ICS525-01 Settings

Use the online ICS525 calculator at www.icst.com/products/ics525inputForm.html or alternatively, the output of the ICS525-01 can be determined by the following simple equation:

$$\text{CLK frequency} = \text{Input frequency} \cdot 2 \cdot \frac{(\text{VDW}+8)}{(\text{RDW}+2)(\text{OD})}$$

Where Reference Divider Word (RDW) = 1 to 127 (0 is not permitted)
 VCO Divider Word (VDW) = 4 to 511 (0, 1, 2, 3 are not permitted)
 Output Divider (OD) = values on page 3

Also, the following operating ranges should be observed:

$$10 \text{ MHz} < \text{Input frequency} \cdot 2 \cdot \frac{(\text{VDW}+8)}{(\text{RDW}+2)} < \begin{matrix} 320 \text{ MHz at 5.0V or} \\ 200 \text{ MHz at 3.3V} \end{matrix}$$

See Table on Page 3
for full details of
maximum output.

$$200 \text{ kHz} < \frac{\text{Input Frequency}}{(\text{RDW}+2)}$$

ICS525-02 Settings

Use the online ICS525 calculator at www.icst.com/products/ics525inputForm.html or alternatively, the output of the ICS525-02 can be determined by the following simple equation:

$$\text{CLK frequency} = \text{Input frequency} \cdot 2 \cdot \frac{(\text{VDW}+8)}{(\text{RDW}+2)(\text{OD})}$$

Where Reference Divider Word (RDW) = 0 to 127
 VCO Divider Word (VDW) = 0 to 511
 Output Divider (OD) = values on page 3

Also, the following operating ranges should be observed:

$$10 \text{ MHz} < \text{Input frequency} \cdot 2 \cdot \frac{(\text{VDW}+8)}{(\text{RDW}+2)} < \begin{matrix} 400 \text{ MHz at 5.0V or} \\ 240 \text{ MHz at 3.3V} \end{matrix}$$

See Table on Page 3
for full details of
maximum output.

$$200 \text{ kHz} < \frac{\text{Input Frequency}}{(\text{RDW}+2)}$$



ICS525-01/02 OSCaR™ User Configurable Clock

The dividers are expressed as integers, so that if a 66.66 MHz output is desired from a 14.31818 input, the Reference Divider Word (RDW) should be 59, and the VCO Divider Word (VDW) should be 276, with an Output divider (OD) of 2. In this example, R6:R0 is 0111011, V8:V0 is 100010100, and S2:S0 is 001. Since all of these inputs have pull-up resistors, it is only necessary to ground the zero pins, namely V7, V6, V5, V3, V1, V0, R6, R2, S2, and S1.

To determine the best combination of VCO, reference, and output divider, use the ICS525 Calculator on our Web site: <http://www.icst.com/products/ics525inputForm.html>. This online form is easy to use and quickly shows you up to three options for these settings.

You may also fax this page to ICS at 408 295 9818(fax), or contact us via our website at www.icst.com. Be sure to indicate the following:

Your Name _____ Company Name _____ Telephone _____

Respond by e-mail (list your e-mail address) _____ or fax number _____

Desired input crystal/clock (in MHz) _____ Desired output frequency _____

VDD = 3.3V or 5V _____ Duty Cycle: 40-60% _____ or 45-55% required _____



ICS525-01/02 OSCaR™ User Configurable Clock

Electrical Specifications

Parameter	Conditions	Minimum	Typical	Maximum	Units
ABSOLUTE MAXIMUM RATINGS (stresses beyond these can permanently damage the device)					
Supply Voltage, VDD	Referenced to GND			7	V
Inputs	Referenced to GND	-0.5		VDD+0.5	V
Clock Output	Referenced to GND	-0.5		VDD+0.5	V
Ambient Operating Temperature	Commercial	0		70	°C
	Industrial	-40		85	°C
Soldering Temperature	Max of 10 seconds			260	°C
Storage Temperature		-65		150	°C
DC CHARACTERISTICS (VDD = 3.3 V unless otherwise noted)					
Operating Voltage, VDD		3		5.5	V
Input High Voltage, VIH		2			V
Input Low Voltage, VIL				0.8	V
Input High Voltage, VIH, X1/ICLK only	ICLK (Pin 7)	(VDD/2)+1	VDD/2		V
Input Low Voltage, VIL, X1/ICLK only	ICLK (Pin 7)		VDD/2	(VDD/2)-1	V
Output High Voltage, VOH	IOH = -12 mA	VDD-0.4			V
Output Low Voltage, VOL	IOL=12 mA			0.4	V
IDD Operating Supply Current, 15 MHz crystal	60MHz out, No Load		8		mA
IDD Operating Supply Current, Power Down	Pin 19=0		7		µA
Short Circuit Current	CLK and REF outputs		±55		mA
On-Chip Pull-up Resistor	All V, R, S pins and pin 19		270		k
Input Capacitance	All V, R, S pins and pin 19		4		pF



ICS525-01/02 OSCaR™ User Configurable Clock

Electrical Specifications (cont.)

Parameter	Conditions	Minimum	Typical	Maximum	Units
AC CHARACTERISTICS (VDD = 3.3 V unless otherwise noted)					
Input Frequency, crystal input		5		27	MHz
Input Frequency, clock input		0.5		50	MHz
Output Frequency, VDD = 4.5 to 5.5V ICS525-01, note 1	0 °C to 70 °C	1		160	
	-40 °C to +85 °C	1		140	MHz
Output Frequency, VDD = 3.0 to 3.6V ICS525-01, note 1	0 °C to 70 °C	1		100	
	-40 °C to +85 °C	1		90	MHz
Output Frequency, VDD = 4.5 to 5.5V ICS525-02, note 1	-40 °C to +85 °C	1.5		250	MHz
Output Frequency, VDD = 3.0 to 3.6V ICS525-02, note 1	-40 °C to +85 °C	1		200	MHz
Output Clock Rise Time	0.8 to 2.0V		1		ns
Output Clock Fall Time	2.0 to 0.8V		1		ns
Output Clock Duty Cycle, OD = 2, 4, 6, 8, or 10	at VDD/2	45	49 to 51	55	%
Output Clock Duty Cycle, OD = 3, 5, 7, or 9	at VDD/2	40		60	%
Output Clock Duty Cycle, OD = 1 (-02 only)	at VDD/2	35		65	
Power Down Time, PD low to clocks stopped				50	ns
Power Up Time, PD high to clocks stable				10	ms
Absolute Clock Period Jitter, ICS525-01, Note 2	Deviation from mean		±140		ps
One Sigma Clock Period Jitter, ICS525-01, Note 2	One Sigma		45		ps
Absolute Clock Period Jitter, ICS525-02, Note 2	Deviation from mean		±85		ps
One Sigma Clock Period Jitter, ICS525-02, Note 2	One Sigma		30		ps

Note 1: The phase relationship between input and output can change at power up. For a fixed phase relationship see the ICS527.

Note 2: For 16 MHz input, 100 MHz output. Use the -02 for lowest jitter.



ICS525-01/02 OSCaR™ User Configurable Clock

Package Outline and Package Dimensions (For current dimensional specifications, see JEDEC Publication No. 95.)

28 pin SSOP

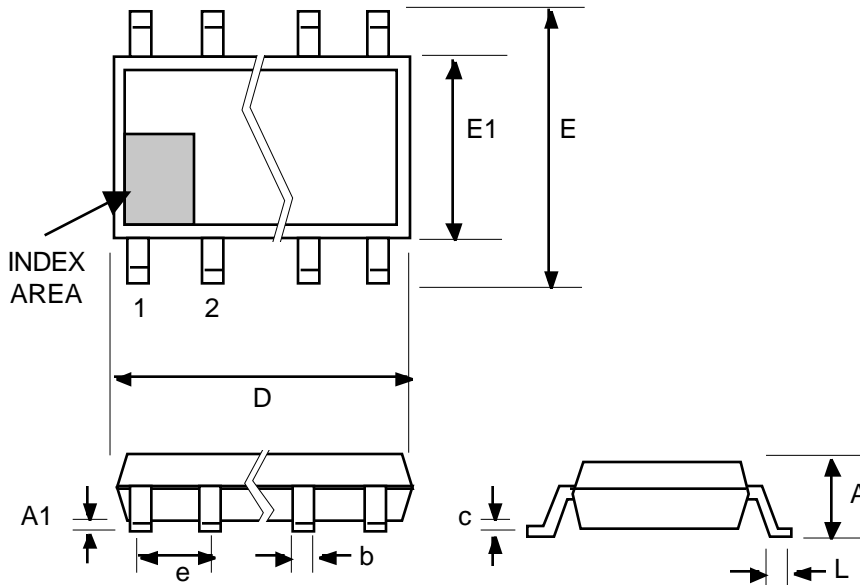

Symbol	Inches		Millimeters	
	Min	Max	Min	Max
A	0.053	0.069	1.35	1.75
A1	0.004	0.010	0.10	0.25
b	0.008	0.012	0.20	0.30
c	0.007	0.010	0.18	0.25
D	0.337	0.344	8.55	8.75
e	.025 BSC		0.635 BSC	
E	0.228	0.244	5.80	6.20
E1	0.150	0.157	3.80	4.00
L	0.016	0.050	0.40	1.27

Ordering Information

Part/Order Number	Marking	Package	Temperature
ICS525-01R	525-01R	28 pin narrow SSOP	0 to 70 °C
ICS525-01RT	525-01R	28 pin SSOP on tape and reel	0 to 70 °C
ICS525-01RI	525-01RI	28 pin narrow SSOP	-40 to +85 °C
ICS525-01RIT	525-01RI	28 pin SSOP on tape and reel	-40 to +85 °C
ICS525R-02I	ICS525R-02I	28 pin narrow SSOP	-40 to +85 °C
ICS525R-02IT	ICS525R-02I	28 pin SSOP on tape and reel	-40 to +85 °C

While the information presented herein has been checked for both accuracy and reliability, Integrated Circuit Systems, Inc. (ICS) assumes no responsibility for either its use or for the infringement of any patents or other rights of third parties, which would result from its use. No other circuits, patents, or licenses are implied. This product is intended for use in normal commercial applications. Any other applications such as those requiring extended temperature range, high reliability, or other extraordinary environmental requirements are not recommended without additional processing by ICS. ICS reserves the right to change any circuitry or specifications without notice. ICS does not authorize or warrant any ICS product for use in life support devices or critical medical instruments.

OSCaR is a trademark of Integrated Circuit Systems