

GL317

3-TERMINAL POSITIVE ADJUSTABLE REGULATOR

Description

The GL317 is a 3-Terminal Adjustable Positive Voltage Regulator capable of supplying in excess of 1.5A over an output voltage range of 1.2V to 37 V. This voltage regulator is exceptionally easy to use and requires only two external resistors to set the output voltage. Further, it employs internal current-limiting, thermal-shutdown and safe-area compensation, making it essentially blow-out proof.

The GL317 serves a wide variety of applications including local, on-card regulation. This device also makes an especially simple adjustable switching regulator, and a programmable output regulator; or by connecting a fixed resistor between the adjustment and output, the GL317 can be used as a precision current regulator.

Pin Configuration (Top View)

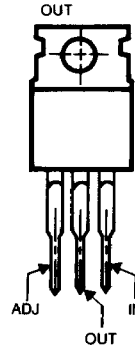

Features

- Output Current in Excess of 1.5 A in TO-220 Package.
- Output Adjustable Between 1.2V and 37V
- Internal Thermal-Overload Protection
- Internal Short-Circuit Current-Limiting Constant Temperature
- Output Transistor Safe-Area Compensation
- Floating Operation for High-Voltage Applications

Absolute Maximum Ratings

Input-Output Voltage Differential	40 V _{dc}
Power Dissipation	Internally Limited
Operating Junction Temperature	0°C to +125°C
Storage Temperature	-55°C to +150°C
Pin Temperature	260°C

(Soldering, 10s Time Limit)

Schematic Diagram

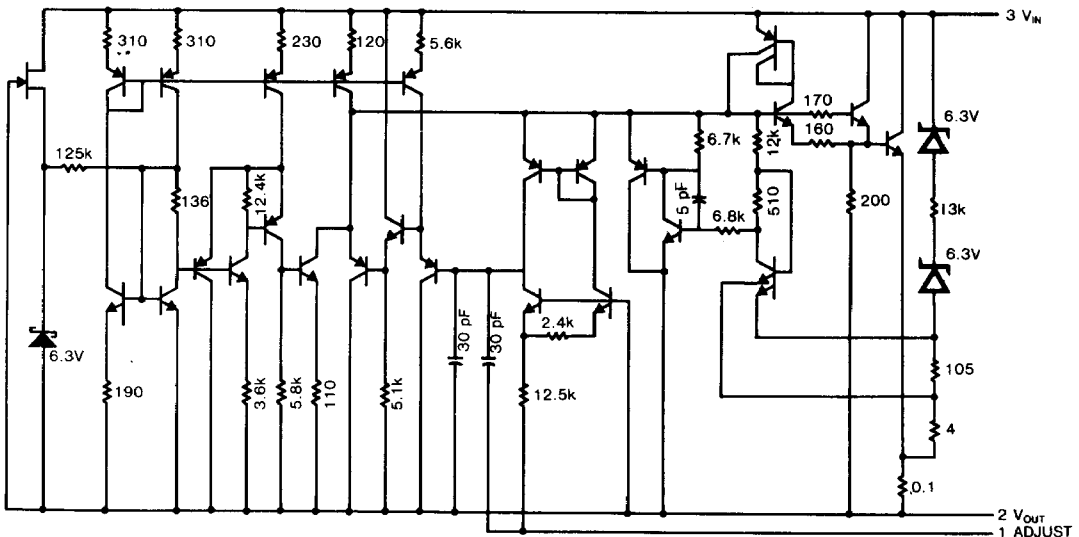

Electrical Characteristics

$V_I - V_O = 5V$; $I_O = 0.5A$

T_J = Operation Temperature; I_{Max} (1.5A) and P_{Max} (20W); unless otherwise specified.

SYMBOL	PARAMETER	CONDITION	GL317			UNIT
			MIN	TYP	MAX	
Reg _{Line}	Line Regulation (Note 5)	$T_A = 25^\circ C$, $3V \leq V_I - V_O \leq 40V$		0.01	0.04	%/V
		$3V \leq V_I - V_O \leq 40V$		0.02	0.07	%/V
Reg _{Load}	Load Regulation (Note 1)	$T_A = 25^\circ C$, $10mA \leq I_O \leq I_{Max}$	$V_O \leq 5V$	5	25	mV
			$V_O \geq 5V$	0.1	0.5	%
		$10mA \leq I_O \leq I_{Max}$	$V_O \leq 5V$	20	70	mV
			$V_O \geq 5V$	0.3	1.5	%
I_{Adj}	Adjustment Pin Current			50	100	μA
ΔI_{Adj}	Adjustment Pin Current Change	$2.5V \leq V_I - V_O \leq 40V$ $10mA \leq I_L \leq I_{Max}$, $P_D \leq P_{Max}$		0.2	5	μA
V_{Ref}	Reference Voltage (Note 2)	$3V \leq V_I - V_O \leq 40V$ $10mA \leq I_O \leq I_{Max}$, $P_D \leq P_{Max}$	1.20	1.25	1.30	V
T_S	Temperature Stability			1		%
$I_{L(Min)}$	Minimum Load Current to Maintain Regulation	$V_I - V_O = 40V$		3.5	10	mA
I_{Max}	Maximum Output Current	$V_I - V_O \leq 15V$, $P_D \leq P_{Max}$	1.5	2.2		A
		$V_I - V_O = 40V$, $P_D \leq P_{Max}$, $T_A = 25^\circ C$		0.4		
N	RMS Noise, % of V_O	$T_A = 25^\circ C$, $10Hz \leq f \leq 10 kHz$		0.003		%
RR	Ripple Rejection (Note 3)	$V_O = 10V$, $f = 120 Hz$	Without C_{Adj}		65	dB
			$C_{Adj} = 10\mu F$	66	80	
S	Long-Term Stability, ($T_J = T_{high}$ (Note 4))	$T_A = 125^\circ C$		0.3	1	%
$R_{\theta JC}$	Thermal Resistance Junction to Case			5		$^\circ C/W$

Notes

1. Load and line regulation are specified at constant junction temperature. Changes in V_O due to heating effects must be taken into account separately. Pulse testing with low duty cycle is used.
2. Selected devices with tightened tolerance reference voltage available.
3. C_{Adj} , when used, is connected between the adjustment pin and ground.
4. Long Term Stability specification is an engineering estimate of average stability from lot to lot.

Application

Standard Application

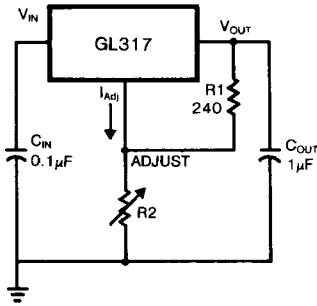

C_{IN} is required if regulator is located an appreciable distance from power supply filter.

$$V_{OUT} = 1.25V \left(1 + \frac{R2}{R1}\right) + I_{Adj} R2$$

Since I_{Adj} is controlled to less than 100 μA , the error associated with this term is negligible in most applications.

Basic Circuit Operation

The GL317 is a 3-terminal floating regulator. In operation, the GL317 develops and maintains a nominal 1.25V reference (V_{REF}) between its output and adjustment terminals. This reference voltage is converted to a programming current (I_{PROG} by R1 (see Figure 1), and this constant current flows through R2 to ground. The regulated output voltage is given by:

$$V_{OUT} = V_{REF} \left(1 + \frac{R2}{R1}\right) + I_{Adj} R2$$

Since the current from the adjustment terminal (I_{Adj}) represents an error term in the equation, the GL317 was designed to control I_{Adj} to less than 0 and keep it constant. To do this, all quiescent operating current is returned to the output terminal. This imposes the requirement for a minimum load current. If the load current is less than this minimum, the output voltage will rise.

Since the GL317 is a floating regulator, it is only the voltage differential across the circuit which is important to performance, and operation at high voltages with respect to ground is possible.

Fig. 1. Basic Circuit Configuration

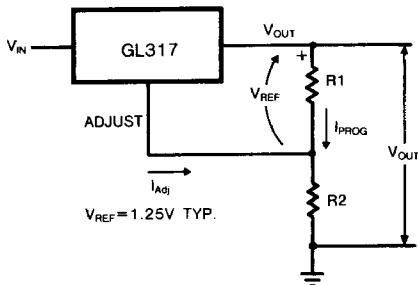

Load Regulation

The GL317 is capable of providing extremely good load regulation, but a few precautions are needed to obtain maximum performance. For best performance, the programming resistor (R1) should be connected as close to the regulator as possible to minimize line drops which effectively appear in series with the reference, thereby degrading regulation. The ground end of R2 can be returned near the load ground to provide remote ground sensing and improve load regulation.

External Capacitors

A 0.1 μF disc or 1.0 μF tantalum input bypass capacitor (C_{IN}) is recommended to reduce the sensitivity to input line impedance.

The adjustment terminal may be bypassed to ground to improve ripple rejection. This capacitor (C_{Adj}) prevents ripple from being amplified as the output voltage is increased. A 10 μF capacitor should improve ripple rejection about 15 dB at 120 Hz in a 10 V application.

Although the GL317 is stable with no output capacitance, like any feedback circuit, certain values of external capacitance can cause excessive ringing. An output capacitance (C_O) in the form of a 1.0 μF tantalum or 25 μF aluminum electrolytic capacitor on the output swamps this effect and insures stability.

Protection Diodes

When external capacitors are used with any IC regulator it is sometimes necessary to add protection diodes to prevent the capacitors from discharging through low current points into the regulator.

Figure 2 shows the GL317 with the recommended protection diodes for output voltages in excess of 25V or high capacitance values ($C_O > 25 \mu F$, $C_{Adj} > 10 \mu F$). Diode D1 prevents C_O from discharging through the IC during an input short circuit. Diode D2 protects against capacitor C_{Adj} discharging through the IC during an output short circuit. The combination of diodes D1 and D2 prevents C_{Adj} from discharging through the IC during an input short circuit.

Fig. 2. Voltage Regulator with Protection Diodes

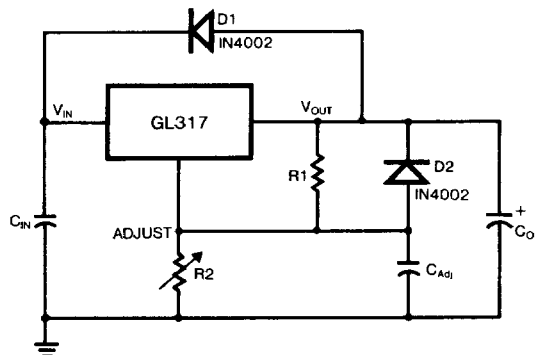

Typical Performance Curves

Load Regulation

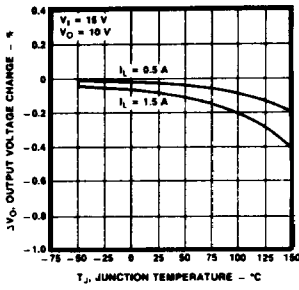

Current Limit

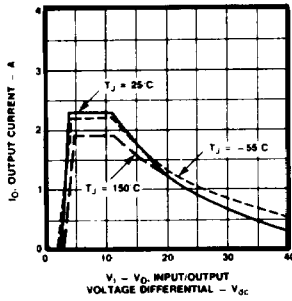

Adjustment Pin Current

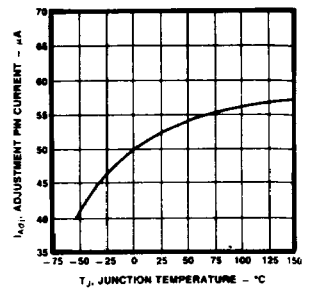

Dropout Voltage

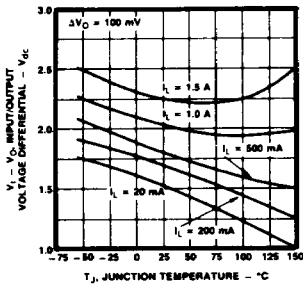

Temperature Stability

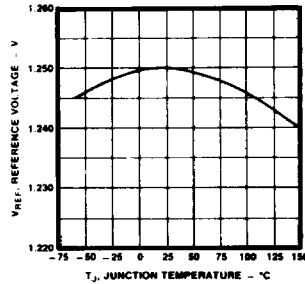

Minimum Operating Current

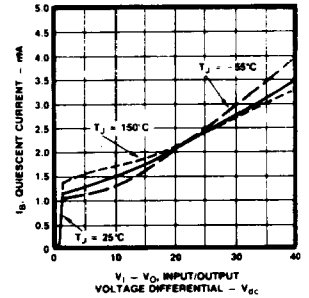

Ripple Rejection as a Function of Output Voltage

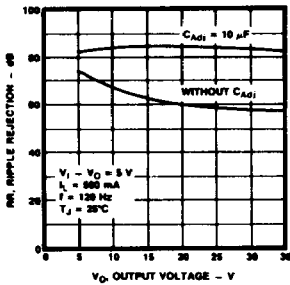

Ripple Rejection as a Function of Output Current

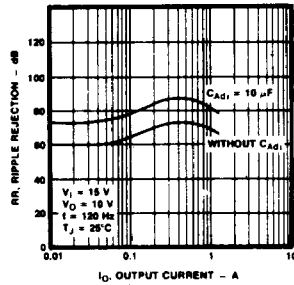

Ripple Rejection as a Function of Frequency

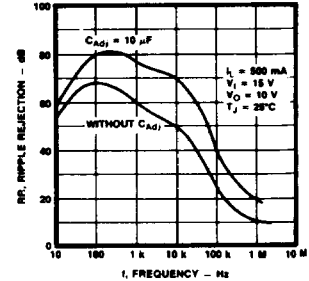

Output Impedance

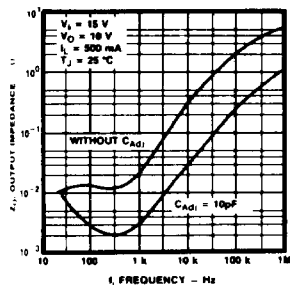

Line Transient Response

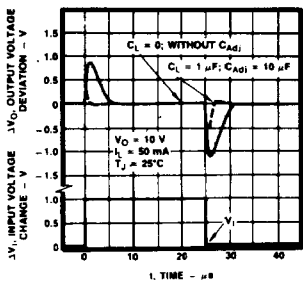

Load Transient Response

