

Standard Capacitors Series RE3

- Guarantees 2000 hours at 85°C.

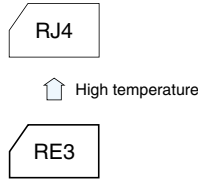

Marking color : White print on a blue sleeve or  
White print on an indigo blue sleeve

Specifications

Item	Performance
Category temperature range (°C)	-40 to +85
Tolerance at rated capacitance (%)	±20 (20°C,120Hz)
Leakage current (µA)	Rated voltage (V) 6.3 to 10 160 to 450
	Leakage current (µA) Less than 0.03CV or 4 whichever is larger(after 1 minute) Less than 0.01CV or 3 whichever is larger(after 2 minutes) CV≤1000: Less than 0.1CV+40(after 1 minute) CV>1000: Less than 0.04CV+100(after 1 minute)
C: Rated capacitance(µF) V: Rated voltage(V) (20°C)	
Tangent of loss angle (tanδ)	Rated voltage (V) 6.3 10 16 25 35 50 63 100 160 200 250 315 350 400 450
	tanδ (max.) 0.28 0.24 0.20 0.16 0.14 0.12 0.10 0.08 0.20 0.20 0.20 0.24 0.24 0.24 0.24
0.02 is added to every 1000µF increase over 1000µF. (20°C,120Hz)	
Characteristics at high and low temperature	Rated voltage (V) 6.3 10 16 25 35 50 63 100 160 200 250 315 350 400 450
	Impedance ratio (max.) Z-25°C / Z+20°C 5 4 3 2 2 2 2 2 4 4 4 4 4 4 4 Z-40°C / Z+20°C 12 10 8 5 4 3 3 3 15 15 15 10 10 10 10
(120Hz)	
Endurance (85°C) (Applied ripple current)	Test time 2000 hours
	Leakage current The initial specified value or less
	Percentage of capacitance change Within ±20% of initial value
	Tangent of the loss angle 200% or less of the initial specified value
Shelf life (85°C)	Test time : 1000 hours; other items are the same as those for the endurance. Voltage application treatment
Applicable standards	JIS C5101-1, -4 1998 (IEC 60384-1 1992, -4 1985)

Outline Drawing

Unit: mm

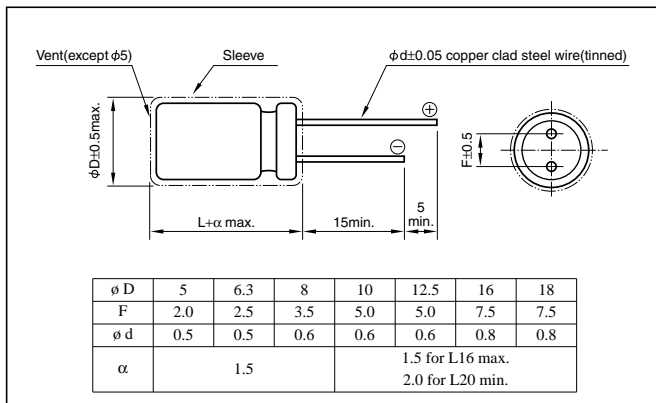

Coefficient of Frequency for Rated Ripple Current

Rated voltage(V)	Frequency(Hz) CV(µF×V)	50 · 60	120	1k	10k	100k
		6.3 to 16	All CV value	0.8	1	1.1
25 to 35	≤1000	0.8	1	1.5	1.7	1.7
	1000<	0.8	1	1.2	1.3	1.3
50 to 100	≤1000	0.8	1	1.6	1.9	1.9
	1000<	0.8	1	1.2	1.3	1.3
160 to 450	All CV value	0.8	1	1.3	1.5	1.6

Part numbering system (example: 16V1000µF)

Environmental item	RE3	—	16	V	102	M	H4	#
	Series code		Rated voltage symbol		Rated capacitance symbol	Capacitance tolerance symbol	Casing symbol	
Former item	RE3	—	16	V	102	M		
	Series code		Rated voltage symbol		Rated capacitance symbol	Capacitance tolerance symbol		

Casing symbol

Size φ DxL(mm)	Casing Symbol	Size φ DxL(mm)	Casing Symbol
5x11	E3	12.5x25	I 6
6.3x11	F3	16x25	J 6
8x11.5	G3	16x31.5	J 7
10x12.5	H3	16x35.5	J 8
10x16	H4	18x35.5	K8
10x20	H5	18x40	K9
12.5x20	I 5		

- The standard ratings are described on the next page.

### Standard Ratings

Rated voltage (V)	Item	6.3			10			16			25			35			50			63			100						
		Case	ESR	Rated ripple current	Case	ESR	Rated ripple current	Case	ESR	Rated ripple current	Case	ESR	Rated ripple current	Case	ESR	Rated ripple current	Case	ESR	Rated ripple current	Case	ESR	Rated ripple current	Case	ESR	Rated ripple current				
		∅D x L (mm)	Ω	mArms	∅D x L (mm)	Ω	mArms	∅D x L (mm)	Ω	mArms	∅D x L (mm)	Ω	mArms	∅D x L (mm)	Ω	mArms	∅D x L (mm)	Ω	mArms	∅D x L (mm)	Ω	mArms	∅D x L (mm)	Ω	mArms				
0.1	—	—	—	—	—	—	—	—	—	—	—	—	—	—	—	5x11	1990	3	—	—	—	5x11	1330	2.1					
0.22	—	—	—	—	—	—	—	—	—	—	—	—	—	—	—	5x11	905	6	—	—	—	5x11	603	4.7					
0.33	—	—	—	—	—	—	—	—	—	—	—	—	—	—	—	5x11	603	9	—	—	—	5x11	402	7					
0.47	—	—	—	—	—	—	—	—	—	—	—	—	—	—	—	5x11	423	13	—	—	—	5x11	282	10					
1	—	—	—	—	—	—	—	—	—	—	—	—	—	—	—	5x11	199	21	—	—	—	5x11	133	21					
2.2	—	—	—	—	—	—	—	—	—	—	—	—	—	—	—	5x11	90.5	31	—	—	—	5x11	60.3	30					
3.3	—	—	—	—	—	—	—	—	—	—	—	—	—	—	—	5x11	60.3	38	—	—	—	5x11	40.2	40					
4.7	—	—	—	—	—	—	—	—	—	—	—	—	—	—	5x11	56.5	38	5x11	49.4	40	5x11	42.3	45	5x11	35.3	45	5x11	28.2	45
10	—	—	—	—	—	—	—	—	5x11	33.2	50	5x11	26.5	55	5x11	23.2	59	5x11	19.9	66	5x11	16.6	66	6.3x11	13.3	75			
22	—	—	—	—	—	—	—	—	5x11	15.1	75	5x11	12.1	82	5x11	10.6	87	5x11	9.05	98	5x11	7.54	100	6.3x11	6.03	130			
33	—	—	—	—	—	—	—	—	5x11	10.1	92	5x11	8.04	100	5x11	7.04	107	5x11	6.03	126	6.3x11	5.03	140	8x11.5	4.02	180			
47	—	—	—	5x11	8.47	99	5x11	7.06	110	5x11	5.65	118	5x11	4.94	130	6.3x11	4.23	155	6.3x11	3.53	170	10x12.5	2.82	230					
100	—	—	—	5x11	3.78	146	5x11	3.32	160	6.3x11	2.65	199	6.3x11	2.32	214	8x11.5	1.99	260	10x12.5	1.66	300	10x20	1.33	370					
220	5x11	2.11	200	6.3x11	1.81	240	6.3x11	1.51	264	8x11.5	1.21	349	10x12.5	1.06	443	10x12.5	0.905	443	10x16	7.54	470	12.5x20	0.603	620					
330	6.3x11	1.41	270	6.3x11	1.21	290	8x11.5	1.01	383	10x12.5	0.804	510	10x12.5	0.704	542	10x16	0.603	595	10x20	0.503	710	12.5x25	0.402	760					
470	6.3x11	0.988	322	8x11.5	0.847	417	8x11.5	0.706	457	10x12.5	0.565	545	10x16	0.494	664	12.5x20	0.423	887	12.5x20	0.353	900	16x25	0.282	1000					
1000	8x11.5	0.464	546	10x12.5	0.398	650	10x16	0.332	791	10x20	0.265	996	12.5x20	0.232	1210	12.5x25	0.199	1400	16x25	0.166	1300	18x40	0.133	1380					
2200	10x20	0.226	1010	10x20	0.196	1080	12.5x20	0.166	1350	12.5x25	0.136	1660	16x25	0.121	1950	16x35.5	0.106	2340	—	—	—	—	—	—	—				
3300	10x20	0.161	1230	12.5x20	0.141	1430	12.5x25	0.121	1690	16x25	0.101	2030	16x35.5	0.09	2510	18x35.5	0.08	2810	—	—	—	—	—	—	—				
4700	12.5x20	0.12	1710	12.5x25	0.106	1780	16x25	0.092	2100	16x31.5	0.078	2650	18x35.5	0.071	2990	—	—	—	—	—	—	—	—	—	—				
6800	12.5x25	0.093	1930	16x25	0.083	2200	16x35.5	0.073	2580	18x35.5	0.063	3290	—	—	—	—	—	—	—	—	—	—	—	—	—				
10000	16x25	0.076	2450	16x35.5	0.07	2700	18x35.5	0.063	3130	—	—	—	—	—	—	—	—	—	—	—	—	—	—	—	—				
15000	16x35.5	0.062	2860	18x35.5	0.058	3100	—	—	—	—	—	—	—	—	—	—	—	—	—	—	—	—	—	—	—				
22000	18x40	0.053	3340	—	—	—	—	—	—	—	—	—	—	—	—	—	—	—	—	—	—	—	—	—	—				

Rated voltage (V)	Item	160			200			250			315			350			400			450				
		Case	ESR	Rated ripple current	Case	ESR	Rated ripple current	Case	ESR	Rated ripple current	Case	ESR	Rated ripple current	Case	ESR	Rated ripple current	Case	ESR	Rated ripple current	Case	ESR	Rated ripple current		
		∅D x L (mm)	Ω	mArms	∅D x L (mm)	Ω	mArms	∅D x L (mm)	Ω	mArms	∅D x L (mm)	Ω	mArms	∅D x L (mm)	Ω	mArms	∅D x L (mm)	Ω	mArms	∅D x L (mm)	Ω	mArms		
0.47	6.3x11	706	15	6.3x11	706	15	6.3x11	706	15	6.3x11	847	15	6.3x11	847	15	6.3x11	847	15	8x11.5	847	18			
1	6.3x11	332	22	6.3x11	332	22	6.3x11	332	22	6.3x11	398	22	6.3x11	398	22	6.3x11	398	22	8x11.5	398	25			
2.2	6.3x11	151	32	6.3x11	151	32	6.3x11	151	32	8x11.5	181	38	8x11.5	181	38	8x11.5	181	38	10x12.5	181	43			
3.3	6.3x11	101	40	6.3x11	101	40	8x11.5	101	48	10x12.5	121	53	10x12.5	121	53	10x12.5	121	54	10x16	121	59			
4.7	6.3x11	70.6	48	8x11.5	70.6	56	8x11.5	70.6	56	10x12.5	84.7	65	10x12.5	84.7	65	10x16	84.7	71	10x20	84.7	76			
10	8x11.5	33.2	81	10x12.5	33.2	94	10x16	33.2	101	10x20	39.8	115	10x20	39.8	115	12.5x20	39.8	123	12.5x20	39.8	123			
22	10x16	15.1	151	10x20	15.1	170	12.5x20	15.1	182	12.5x20	18.1	182	12.5x25	18.1	197	12.5x25	18.1	197	16x25	18.1	226			
33	10x20	10.1	202	12.5x20	10.1	223	12.5x25	10.1	243	16x25	12.1	277	16x25	12.1	277	16x25	12.1	277	16x31.5	12.1	304			
47	12.5x20	7.06	266	12.5x25	7.06	265	12.5x25	7.06	295	16x25	8.47	330	16x25	8.47	330	16x31.5	8.47	361	16x35.5	8.47	380			
100	12.5x25	3.32	422	16x25	3.32	483	16x31.5	3.32	528	18x31.5	3.98	567	18x31.5	3.98	567	—	—	—	—	—	—	—	—	—
220	16x31.5	1.51	783	18x35.5	1.51	882	—	—	—	—	—	—	—	—	—	—	—	—	—	—	—	—	—	—
330	18x35.5	1.01	1080	—	—	—	—	—	—	—	—	—	—	—	—	—	—	—	—	—	—	—	—	—

(Note) ESR : 20°C, 120Hz ; Rated ripple current : 85°C, 120Hz