



DIONICS, INC.

65 Rushmore Street
Westbury, NY 11590

Phone: (516) 997-7474

Fax: (516) 997-7479

Website: www.dionics-usa.com

OPTO-ISOLATED PHOTOVOLTAIC ISO-GATE™ MOSFET DRIVERS

DIG-11-06-030

DIG-11-06-150

DIG-11-08-050

DIG-12-06-025

DIG-12-08-010

DIG-12-08-045

DIG-12-06-100

DIG-12-06-250

Features:

- Completely Isolated Voltage Signal Generation
- Dielectrically Isolated
- Logic Circuit Compatibility
- High Open Circuit Voltage
- High Operating Temperature
- Fast Response Time
- High Isolation Resistance
- Excellent Input/Output Linearity
- Self Limiting Gate Voltage

Applications:

- Gate Drive For MOS devices
- Gate Drive For SCR
- Solid-State Relays
- Interface Between Logic Circuits & External Loads
- A.T.E. (Automatic Test Equipment)
- Switching Equipment
- Isolation Amplifiers
- Load Control From Microprocessor I/O Ports
- Thermocouple Open Detectors

Description:

The photovoltaic MOSFET driver is a State-of-the-Art, optically coupled floating power source used primarily to control MOSFETs when electrical isolation between input and output is required. The ISO-GATE™ is a state-of-the-art opto-isolator incorporating DIONICS' photovoltaic (PV) diode arrays and an infrared LED. The diode array is a unique I.C. consisting of series-connected photovoltaic diodes. The diodes are completely isolated from each other and from their common substrate by means of SiO₂ Dielectric Isolation (DI). These photovoltaic output chips are electrically isolated but optically coupled to the LED.

The typical input circuit to the LED is a limiting resistor connected in series with the LED. When activated, the LED emits infrared light towards the photovoltaic diode array, which then responds by generating an open circuit voltage (Voc). This Voc is floating and is therefore completely isolated. The Voc value depends on the LED input drive and load impedance. DIONICS, Inc offers a wide variety of package styles including low-cost plastic Mini-DIP's, high reliability TO-5 metal cans, 8-pin ceramic side brazed DIP's and ceramic chip carriers for hybrid manufacturers. Other custom packages and custom designs are also available.

- **Group I: DIG-11-06-030; DIG-11-06-150; DIG-11-08-050.**
- **Group II: DIG-12-06-025; DIG-12-06-100; DIG-12-06-250; DIG-12-08-010; DIG-12-08-045.**

❖ Package Layout:

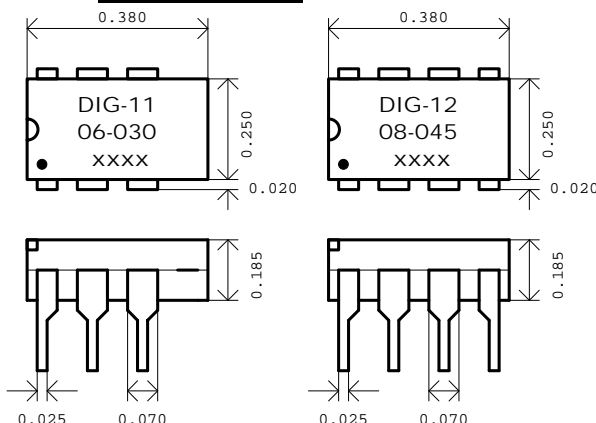

❖ Pin Designation		
Pin Number	Group I	Group II
1	Input +	Input +
2	Input -	Input -
3	Not Connected	Not Connected
4	Not Connected	Not Connected
5	Not Connected	Output 1+
6	Output +	Output 1-
7	Not Connected	Output 2+
8	Output -	Output 2-

Group I and Group II Equivalent Circuits:

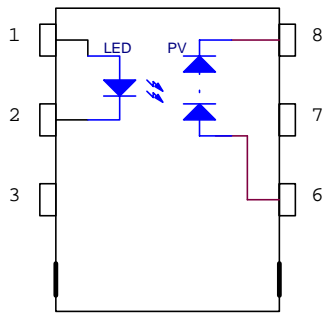

Group I

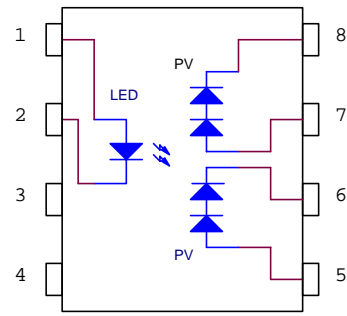

Group II

❖ Absolute Maximum Ratings ($T_a = 25^{\circ}\text{C}$)		
LED Forward Current	Steady State	100 mA
LED Forward Current	Peak 10% Duty Cycle	250 mA
LED Forward Voltage	$I_f = 20\text{mA}$	1.7V*
LED Reverse Current	$V_r = 3\text{V}$	100 μA
LED Reverse Voltage		5V
Output Forward Voltage	$I_f = 10\mu\text{A}$	20V
Lead Soldering Time	At 260°C	10 sec
Storage Temperature		-50 to 125°C
Power Dissipation		150 mW

* Note: DIG-12-06-100 and DIG-12-06-250 are rated @ 3.4 V Max.

❖ Individual Channel Electrical Characteristics ($T_a = 25^{\circ}\text{C}$)

		MODEL NUMBERS DIG -																	
		12-08-010		12-06-025		12-08-045		12-06-100		12-06-250		11-06-030		11-08-050		11-06-150		Unit	
Parameter	Symbol	Min.	Typ.	Min.	Typ.	Min.	Typ.	Min.	Typ.	Min.	Typ.	Min.	Typ.	Min.	Typ.	Min.	Typ.		
Open Circuit Voltage	V_{oc}																		
$I_{led} = 2\text{mA}$			8.0		6.5		8.0		6.0		6.0		5.5		9.0		6.0	V	
$I_{led} = 10\text{mA}$		8.0	9.0	6.5	7.5	8.5	9.0	6.5	7.0	6.5	7.3	6.0	6.5	7.5	10.0	6.5	7.0	V	
$I_{led} = 30\text{mA}$		9.0	10.0	7.0	6.3	9.5	10.0	7.5	7.8	7.5	8.0	6.5	7.0	8.5	11.0	7.5	8.0	V	
Short Circuit Current	I_{sc}																		
$I_{led} = 2\text{mA}$			0.5		1.0		1.0		2.0		3.0		1.1		2.0		3.0	μA	
$I_{led} = 10\text{mA}$		1.35	3.0	3.0	6.0	4.0	8.0	8.0	12.0	12.5	25.0	1.0	7.0	4.0	13.0	10.0	18.0	μA	
$I_{led} = 30\text{mA}$		4.0	9.0	9.0	20.0	12.0	25.0	30.0	40.0	37.5	75.0	3.5	20.0	12.0	40.0	30.0	55.0	μA	
Turn-On Time $I_f = 50\text{ mA}; C = 10\text{pF}$ P.W = 100us; $f = 1\text{kHz}; R_s = 10\text{M}\Omega$	T_{on}	-	3.0	-	10.0	-	8.0	-	3.0	-	3.0	-	8.0	-	5.0	-	3.0	μs	
Temp. Coefficient (Channels in Series)	Θ	-	-100	-	-80	-	-100	-	-80	-	-80	-	-40	-	-50	-	-40	$\text{mV}/^{\circ}\text{C}$	
Isolation Voltage $I_{iso} = 50\mu\text{A} @ 2\text{ sec}$	V_{iso}	2500										2500						VDC	
Operating Temp. (Channels in Series)	T_{op}	-50 $^{\circ}\text{C}$ To +100 $^{\circ}\text{C}$										-50 $^{\circ}\text{C}$ To +80 $^{\circ}\text{C}$							
Turn-Off Time $I_f = 50\text{ mA}; C = 10\text{pF}$ P.W = 100us; $f = 1\text{kHz}; R_s = 10\text{M}\Omega$	T_{off}	The Photovoltaic array stops generating current within one microsecond of the trailing edge of LED current the discharge time is solely dependent upon discharge circuitry and capacitive load.																	

Typical Applications

1. Power MOSFET Photovoltaic SPST N/O DC Relays

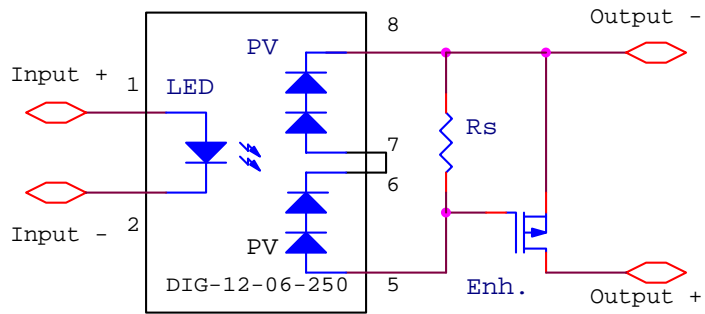

2. Power MOSFET SPDT Photovoltaic SPST N/O AC-DC Relays:

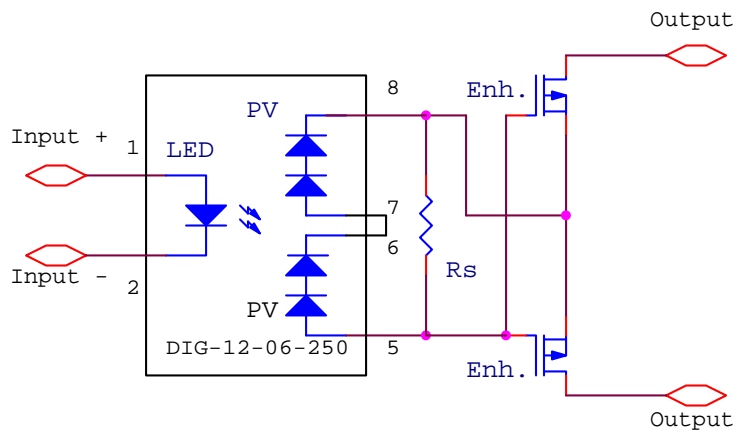

3. Power MOSFET Photovoltaic SPST N/O Relays With High Speed Turn-Off:

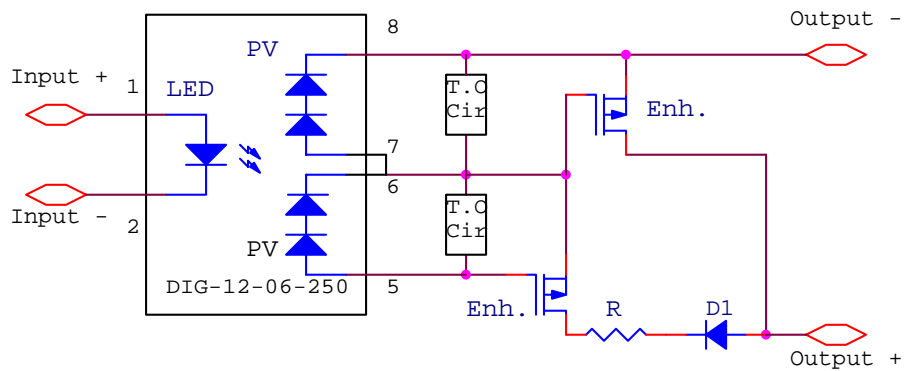

4. Power MOSFET Photovoltaic SPST N/O Relays With Opto-Transistor for High Speed Turn-Off:

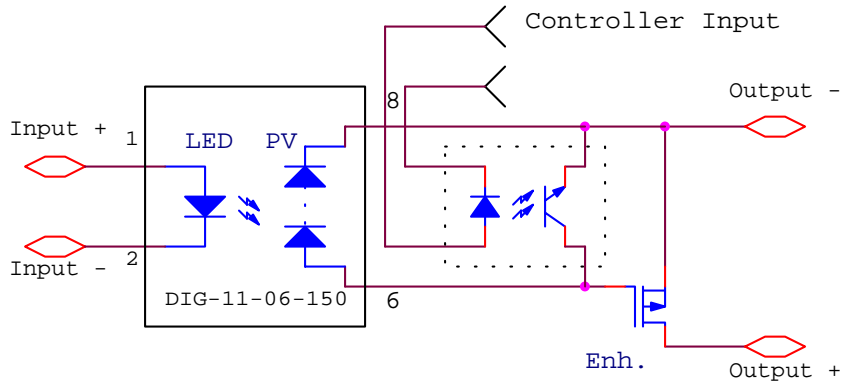

5. Open Thermocouple Detector:

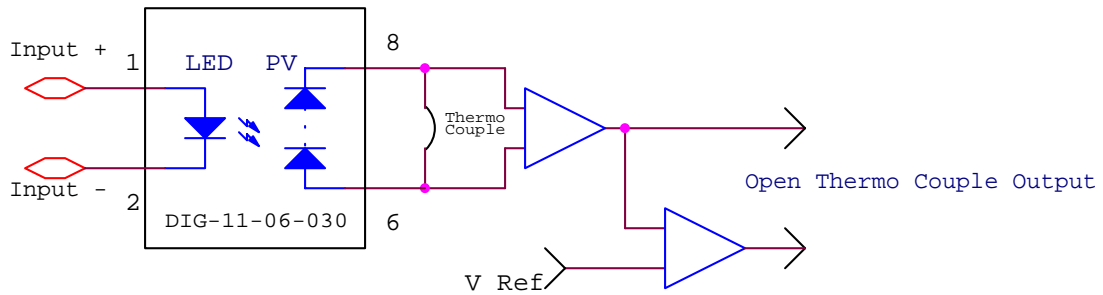

6. Isolation Amplifier:

