

BOURNS®

Features

- Single-Turn Cermet / Open Frame
- Recommended for reflow processing
- Rotor design compatible with automatic adjustment equipment
- Supplied in 8 mm embossed tape, compatible with automatic assembly equipment
- 2 mm size meets EIA/EIAJ standard trimmer footprint
- RoHS compliant* - see [processing information](#) on lead free surface mount trimmers

3302 - 2 mm SMD Trimming Potentiometer

Electrical Characteristics

Standard Resistance Range200 to 1 megohm
 (see standard resistance table)
 Resistance Tolerance±25 % std.
 Absolute Minimum Resistance
 ≤1K20 ohms max.
 >1K5 % max.
 Contact Resistance Variation
5 % max.
 ResolutionInfinite
 Adjustment Angle260 ° ±20 °

Environmental Characteristics

Power Rating (50 VDC max.)
 70 °C0.15 watt
 Temperature Range
-40 °C to +85 °C
 Temperature Coefficient
±250 ppm/°C
 Humidity95 % RH
 500 hours
 TRS max.±5 %
 Load Life
@ 70 °C rated power 500 hours
 TRS ±5 %
 Rotational Cycling10 turns
 TRS ±15 %

Physical Characteristics

Torque10-150 g-cm max.
 Mechanical AngleContinuous
 MarkingPart marking code
 Standard Packaging ...2000 pcs./7 " reel
 Adjustment ToolH-91

How To Order

3302 X - 3 - 103 E

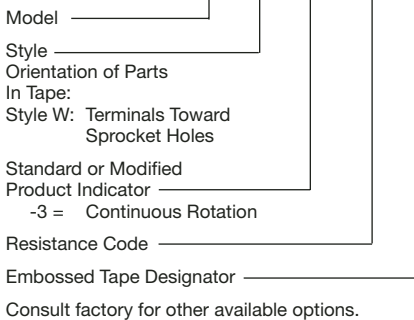

**3302W, X-3
 3 Terminals for
 Automatic Trimming Adjustment
 Low Profile**

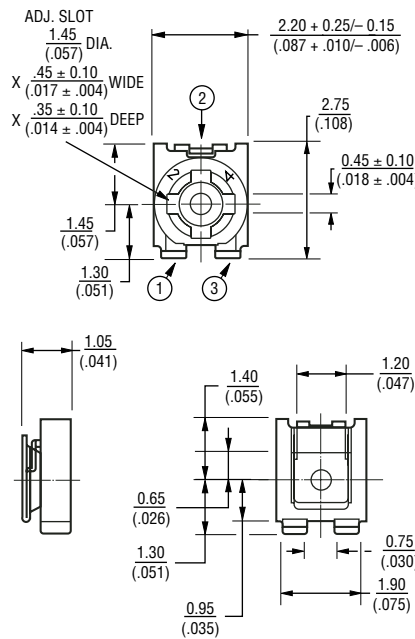

SUGGESTED PWB LAYOUT

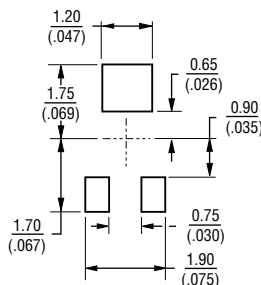

Packaging Specifications

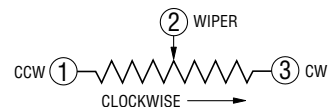
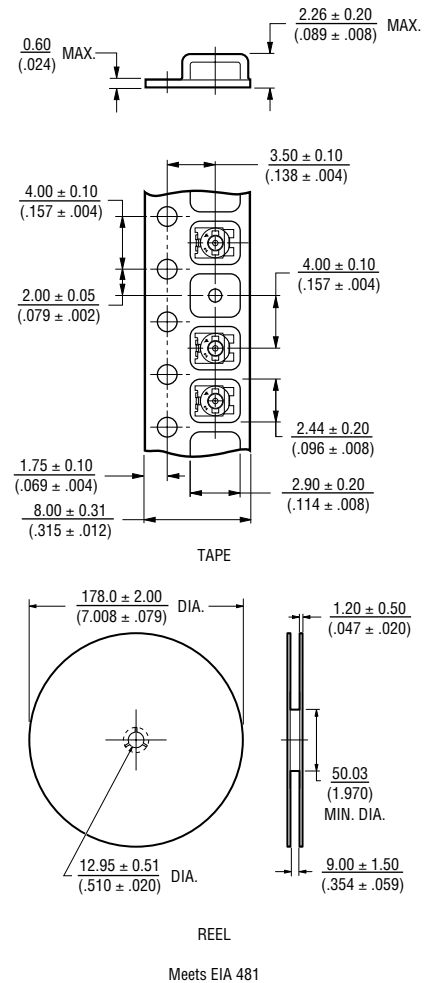

Standard Resistance Table

Resistance (Ohms)	Part Marking Code	Resistance Code
200	22	201
500	52	501
1,000	13	102
2,000	23	202
5,000	53	502
10,000	14	103
20,000	24	203
50,000	54	503
100,000	15	104
200,000	25	204
500,000	55	504
1,000,000	16	105

TOLERANCES: ± 0.25 (.010) EXCEPT WHERE NOTED

DIMENSIONS ARE: $\frac{\text{MM}}{(\text{INCHES})}$

Popular distribution resistance values listed in boldface. Special resistances available.

REV. 09/04

*RoHS Directive 2002/95/EC Jan 27 2003 including Annex. Specifications are subject to change without notice. Customers should verify actual device performance in their specific applications.