

AVX
A KYOCERA GROUP COMPANY



AVX
Military Products

Military Products

AVX Military Qualified Products Listing Table of Contents



Multilayer Ceramic Leaded Capacitors – Military Cross Reference 3-31

MIL-PRF-39014	MIL-PRF-20 Non-Established Reliability
M, P, R and S Failure Rate Level	/27, /28, /29, /30, /31, /35, /36, /37, /38. 19
/01, /02, /05, /20 (M Level Only), /23 4	MIL-PRF-20 Established Reliability
M, P, R and S Failure Rate Level	/27, /28, /29, /30, /31, /35, /36, /37, /38. 19
/22 10	MIL-PRF-123
MIL-PRF-11015	/01, /02, /04, /05, /06, /07, /08, /16, /17, /18. 24
/18, /19, /20, /25 15	Multilayer Packaging Tape and Reel 30

Military Glass/Glass-K Capacitors – Military Cross Reference 32-44

MIL-PRF-11272	MIL-PRF-11015
/01, /02, /03, /04, /13, /14, /15 33	/25 41
MIL-PRF-23269 Established Reliability	MIL-PRF-39014
/01, 3001-3126, 7001-7126, /02, 3001-3057, 7001-7057	/21 43
/03, 3001-3072, 7001-7057, /04, 3001-3036, 7001-7021	
/10, 3001-3150, 3201-3218, 3301-3327 37	

Military Surface Mount and Microwave Capacitors 45-56

MIL-PRF-55681	Packaging Automatic Insertion 55
M, P, R and S Failure Rate Level	Packaging Punched Carrier Configuration 56
/01, /02, /03, /07, /08, /09, /10, /11 46	
M, P, R and S Failure Rate Level	
/04 52	

Military Tantalum Capacitors 57-84

MIL-PFR-55365 Established Reliability	Packaging Tape and Reel 79
/04, /08 59	TRJ Series – Professional Tantalum Chip Capacitor
TAZ Series – CWR09 and TAZ COTS-Plus	also available as COTS-Plus 80
/04, /08 66	TMC Series – Established Reliability
TBJ Series – CWR11 and TBJ COTS-Plus	TACmicrochip™ 83
/04, /08 72	

Military SMPS Capacitors 85-99

SM Style MIL-PRF-49470	SM Style
/01, /02 85	DSCC DW. #87106 & 88011 93

Military High Voltage MLC Capacitors 100-101

Military Single-In-Line Packages (SIP) 102

Military EMI/RFI Filters 103-108

MIL-PRF-28861 QPL List	TPC Power Capacitors for
MIL-PRF-28861/01, /04, /05, /12 103	Military Applications 109

Military SMPS Capacitors Chip Assemblies (European Preferred Styles) 111-116

CH/CV -	CH/CV -
Radial, Dual-in-Line 111	C0G Dielectric Ultra Stable Ceramic 115
CV Style 112	X7R Dielectric Stable Ceramic 116
CH Style 113	

Military High Voltage Leaded Chip Assemblies (European Preferred Styles) 117-121

CH Style -	CH/CV -
Radial, Dual-in-Line 117	1B/C0G Ultra Stable Ceramic 119
CV Style 118	2C1/X7R Stable Ceramic 120
	BS9100 Requirements 121

Military ESA Qualified SMPS Capacitors 122-123

High Voltage Chip/Leaded Capacitors 122	High Capacitance 123
--	-----------------------------------



AVX Corporation has been a leading supplier of high reliability electronic components to the medical, military and aerospace industries for many years.

Building on the technology demands of these high performance applications, AVX has been able to release many new and unique products, and also provides regular extensions to existing product ranges. These include higher bulk capacitance ratings, new case sizes and low ESR options.

This catalog contains detailed information on the wide range products available from AVX. These include devices manufactured to MIL-PRF standards, ESA qualified parts and a broad offering of enhanced and customized testing options as detailed below:

- Destructive Physical Analysis (DPA)
- Ultrasonic Scanning
- Serialized Date/Testing
- Special X-Ray
- Low Voltage Humidity Testing
- Matched Pairs
- Special Packaging

We have the widest range military approved ceramic capacitors available and have a long history as the premium supplier in the industry. Special facilities are also available which enable the production of application specific modules and arrays for custom applications. Many of our products are also manufactured in accordance with AECQ 200 an Automotive standard, which is becoming more widely used in high reliability applications.

In addition to the broad range of military approvals held by AVX production locations around the World, all our manufacturing facilities are ISO9001 registered.

MIL-PRF-20 Non-Established Reliability

50V, 100V 200V (CG, CH, CJ, CK, CX)

Style CC05, CC06, CC07, CC08, CC09, CC75, CC76, CC77, CC78, CC79

Slash Sheets /27, /28, /29, /30, /31, /32, /33, /34, /35, /36, /37, /38

MIL-PRF-20 Established Reliability

M, P, R and S Failure Rate Level

50V, 100V 200V (CX, CK, CJ, CH, CG)

Style CCR05, CCR05V CCR06, CCR06V CCR07, CCR08, CCR09, CCR75, CCR76, CCR77, CCR78, CCR79

Slash Sheets /27, /28, /29, /30, /31, /32, /33, /34, /35, /36, /37, /38

MIL-PRF-11015

50V, 100V 200V (BR, BX, BT, BU and BV)

Style CK05, CK06, CK12, CK13, CK14, CK15, CK16, CK31, CK32

Slash Sheets /18, /19, /20, /25

MIL-PRF-123

50V, 100V (BP, BX, and BR)

Style CKS05, CKS06, CKS11, CKS12, CKS14, CKS15, CKS16, CKS22, CKS23, CKS24

Slash Sheets /01, /02, /04, /05, /06, /07, /08, /16, /17, /18

MIL-PRF-39014

M, P, R and S Failure Rate Level

50V, 100V, 200V (BR, BX BT, BU and BV)

Style CKR04, CKR05, CKR05V, CKR06, CKR06V, CKR08 (M-Level only), CKR11, CKR12, CKR14, CKR15, CKR16, CKR31, CKR32

Slash Sheets /01, /02, /05, /20, /21, /23

M, P, R and S Failure Rate Level

50V, 100V, 200V (CG, CH, BX and BR)

Style CKR22, CKR23, CKR24

Slash Sheet /22

Military Ceramic Leaded Capacitors



Cross Reference Guide For Military Ceramic Leaded Capacitors

MILITARY MOLDED RADIAL LEAD

millimeters (inches)

Figure	AVX Style	Per Mil Spec			Case Size				
		MIL-PRF-11015	MIL-PRF-39014	MIL-PRF-20	Length (L)	Width (W)	Thickness (T)	Lead Spacing (LS)	Lead Diameter (L.D.)
1	MR05	CK05	CKR05	CCR05/CC05	4.83±.25 (0.190±0.010)	4.83±.25 (0.190±0.010)	2.29±.25 (0.090±0.010)	5.08±.38 (0.200±0.015)	.64±.05 (0.025±0.002)
2	MR04	—	CKR04	CCR09/CC09	4.83±.25 (0.190±0.010)	4.83±.25 (0.190±0.010)	2.29±.25 (0.190±0.010)	2.54±.38 (0.100±0.015)	.64±.05 (0.025±0.002)
2	MR06	CK06	CKR06	CCR06/CC06	7.37±.25 (0.290±0.010)	7.37±.25 (0.290±0.010)	2.29±.25 (0.090±0.010)	5.08±.38 (0.200±0.015)	.64±.05 (0.025±0.002)
2	MR68	—	CKR08	—	7.37±.25 (0.290±0.010)	7.37±.25 (0.290±0.010)	3.68±.38 (0.145±0.015)	5.08±.38 (0.200±0.015)	.64±.05 (0.025±0.002)
2	MR07	—	—	CCR07/CC07	12.19±.51 (0.480±0.020)	12.19±.51 (0.480±0.020)	3.56±.25 (0.140±0.010)	10.16±.51 (0.400±0.020)	.64±.05 (0.025±0.002)
2	MR08	—	—	CCR08/CC08	12.19±.51 (0.480±0.020)	12.19±.51 (0.480±0.020)	6.1±.25 (0.240±0.010)	10.16±.51 (0.400±0.020)	.64±.05 (0.025±0.002)

MILITARY MOLDED AXIAL LEAD

millimeters (inches)

AVX Style	Per Mil Spec			Case Size		
	MIL-PRF-11015	MIL-PRF-39014	MIL-PRF-20	Length (L)	Diameter (D)	Lead Diameter (L.D.)
MA10	CK12	CKR11	CCR75/CC75	4.07 ±.25 (0.160±0.010)	2.29±.25 (0.090±0.010)	.48±.05 (0.019±0.002)
MA20	CK13	CKR12	CCR76/CC76	6.35 ±.25 (0.250 ±0.010)	2.29±.25 (0.090±0.010)	.48±.05 (0.019±0.002)
MA30	—	—	—	6.10 ±.25 (0.240±0.010)	3.30±.25 (0.130±0.010)	.48±.05 (0.019±0.002)
MA40	CK14	CKR14	CCR77/CC77	9.91±.25 (0.390±0.010)	3.56±.25 (0.140±0.010)	.63±.05 (0.025±0.002)
MA50	CK15	CKR15	CCR78/CC78	12.7±.51 (0.500±0.020)	6.35±.38 (0.250±0.015)	.63±.05 (0.025±0.002)
MA60	CK16	CKR16	CCR79/CC79	17.53±.51 (0.690±0.020)	8.89±.51 (0.350±0.015)	.63±.05 (0.025±0.002)

MILITARY MIL-PRF-123/PARTS

MIL-PRF-123		MIL-PRF-39014		MIL-PRF-20		MIL-PRF-55681		AVX CATALOG
CKS #	M123/ -	CKR #	M39014/ -	CCR #	M20/ -	CDR #	M55681/ -	
CKS05	/01	CKR05	/01	CCR05	/35	N/A	N/A	MR05
CKS06	/02	CKR06	/02	CCR06	/36	N/A	N/A	MR06
CKS11	/04	CKR11	/05	CCR75	/27	N/A	N/A	MA10
CKS12	/05	CKR12	/05	CCR76	/28	N/A	N/A	MA20
CKS14	/06	CKR14	/05	CCR77	/29	N/A	N/A	MA40
CKS15	/07	CKR15	/05	CCR78	/30	N/A	N/A	MA50
CKS16	/08	CKR16	/05	CCR79	/31	N/A	N/A	MA60
CKS22	/16	CKR22	/22	N/A	N/A	N/A	N/A	MD01
CKS23	/17	CKR23	/22	N/A	N/A	N/A	N/A	MD02
CKS24	/18	CKR24	/22	N/A	N/A	N/A	N/A	MD03

Military Ceramic Leaded Capacitors



MIL-PRF-39014/01, /02, /20, /23 - Radial Leads

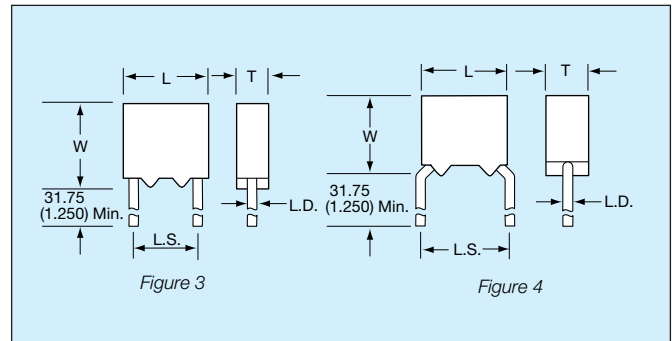
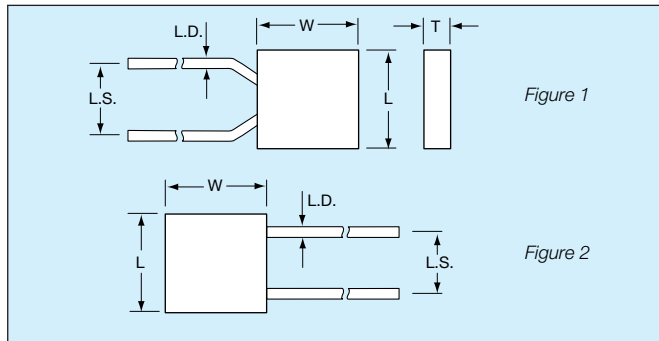

HOW TO ORDER

Military Type Designation: Styles CKR04, CKR05, CKR06, CKR08

Dash Number Option: MIL-PRF-39014/01 (Appropriate Dash Number)

CKR05

Style

BX

Voltage-Temperature Limits

104

Capacitance Code

K

Capacitance Tolerance

S

Military Failure Rate

(V)

Stand-off Option

MIL PART NO. CODES

Style: **CK** = General purpose, ceramic dielectric, fixed capacitors.

R = Established Reliability parts.

05 = Remaining two numbers identify shape and dimension.

Voltage-Temperature Limits:

First letter identifies temperature range. B = -55°C to +125°C

Second letter identifies voltage-temperature coefficient.

Capacitance Change with Reference to 25°C		
Second Letter	No Voltage	Rated Voltage
X	+15, -15%	+15, -25%

Fig. Fig. Capacitance and Multiplier:

First two digits are the significant figures of capacitance. Third digit indicates the additional number of zeros. For example, order 100,000 pF as 104. (For values below 10 pF, use "R" in place of decimal point, e.g., 1R4 = 1.4 pF).

Capacitance Tolerances: K = ±10%, M = ±20%

Military Failure Rate: M = 1% per 1000 hours; P = 0.1% per 1000 hours; R = 0.01% per 1000 hours; S = 0.001% per 1000 hours

Note: AVX reserves the right to substitute a lower failure rate part per MIL-PRF-39014. Substitutability for failure rate levels shall be as follows:

Failure Rate Level	Will Replace Failure Rate Level
S (STD) (X-ray)	R, P, M, L
R (STD) (No X-ray)	P, M, L
P	M, L
M	L

To order stand-off option, place "V" at the end of the part number. For example: CKR05BX104KSV.

PACKAGING REQUIREMENTS

Packaging: 100 Pcs/bag; Radial Tape and Reel Packaging available upon request (2500 pcs./reel).

SIZE SPECIFICATIONS millimeters (inches)

Per Mil Spec	Case Size				
	Length (L)	Width (W)	Thickness (T)	Lead Spacing (L.S.)	Lead Diameter (L.D.)
MIL-PRF-39014					
CKR04 (Fig. 2)	4.83±.25 (0.190±0.010)	4.83±.25 (0.190±0.010)	2.29±.25 (0.090±0.010)	2.54±.38 (0.100±0.015)	.64±.05 (0.025±0.002)
CKR05 (Fig. 1, 4)	4.83±.25 (0.190±0.010)	4.83±.25 (0.190±0.010)	2.29±.25 (0.090±0.010)	5.08±.38 (0.200±0.015)	.64±.05 (0.025±0.002)
CKR06 (Fig. 2, 3)	7.37±.25 (0.290±0.010)	7.37±.25 (0.290±0.010)	2.29±.25 (0.090±0.010)	5.08±.38 (0.200±0.015)	.64±.05 (0.025±0.002)
CKR08 (Fig. 2)	7.37±.25 (0.290±0.010)	7.37±.25 (0.290±0.010)	3.68±.38 (0.145±0.015)	5.08±.38 (0.200±0.015)	.64±.05 (0.025±0.002)

MARKING RADIAL LEAD

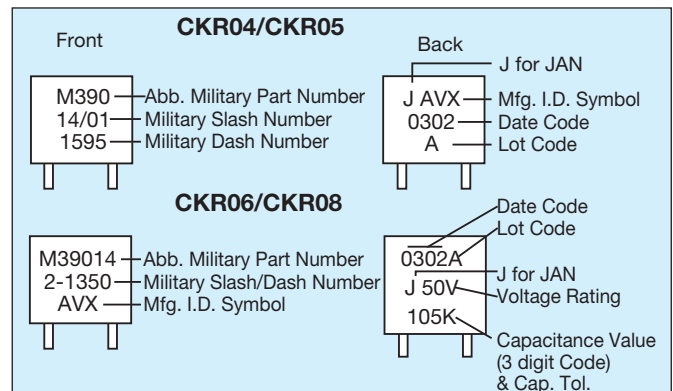

Military Ceramic Leaded Capacitors



MIL-PRF-39014/01, /02, /20, /23 - Radial Leads

MILITARY DASH NUMBER IDENTIFICATION CKR04 TO MIL-PRF-39014/23 (Dash Number From Table)

Military Type Designation	Failure Rate Level (%/1,000 Hours)				Capacitance (pF)	Capacitance Tolerance ±Percent	WVDC
	1.0 (M)	0.1 (P)	0.01 (R)	0.001 (S)			
CKR04 (BX)							
CKR04BX100K_	0001	0101	0201	0301	10	10	200
CKR04BX100M_	0002	0102	0202	0302	10	20	200
CKR04BX120K_	0003	0103	0203	0303	12	10	200
CKR04BX150K_	0004	0104	0204	0304	15	10	200
CKR04BX150M_	0005	0105	0205	0305	15	20	200
CKR04BX180K_	0006	0106	0206	0306	18	10	200
CKR04BX220K_	0007	0107	0207	0307	22	10	200
CKR04BX220M_	0008	0108	0208	0308	22	20	200
CKR04BX270K_	0009	0109	0209	0309	27	10	200
CKR04BX330K_	0010	0110	0210	0310	33	10	200
CKR04BX330M_	0011	0111	0211	0311	33	20	200
CKR04BX390K_	0012	0112	0212	0312	39	10	200
CKR04BX470K_	0013	0113	0213	0313	47	10	200
CKR04BX470M_	0014	0114	0214	0314	47	20	200
CKR04BX560K_	0015	0115	0215	0315	56	10	200
CKR04BX680K_	0016	0116	0216	0316	68	10	200
CKR04BX680M_	0017	0117	0217	0317	68	20	200
CKR04BX820K_	0018	0118	0218	0318	82	10	200
CKR04BX101K_	0019	0119	0219	0319	100	10	200
CKR04BX101M_	0020	0120	0220	0320	100	20	200
CKR04BX121K_	0021	0121	0221	0321	120	10	200
CKR04BX151K_	0022	0122	0222	0322	150	10	200
CKR04BX151M_	0023	0123	0223	0323	150	20	200
CKR04BX181K_	0024	0124	0224	0324	180	10	200
CKR04BX221K_	0025	0125	0225	0325	220	10	200
CKR04BX221M_	0026	0126	0226	0326	220	20	200
CKR04BX271K_	0027	0127	0227	0327	270	10	200
CKR04BX331K_	0028	0128	0228	0328	330	10	200
CKR04BX331M_	0029	0129	0229	0329	330	20	200
CKR04BX391K_	0030	0130	0230	0330	390	10	200
CKR04BX471K_	0031	0131	0231	0331	470	10	200
CKR04BX471M_	0032	0132	0232	0332	470	20	200
CKR04BX561K_	0033	0133	0233	0333	560	10	200
CKR04BX681K_	0034	0134	0234	0334	680	10	200
CKR04BX681M_	0035	0135	0235	0335	680	20	200
CKR04BX821K_	0036	0136	0236	0336	820	10	200
CKR04BX102K_	0037	0137	0237	0337	1,000	10	200
CKR04BX102M_	0038	0138	0238	0338	1,000	20	200
CKR04BX122K_	0039	0139	0239	0339	1,200	10	100
CKR04BX152K_	0040	0140	0240	0340	1,500	10	100
CKR04BX152M_	0041	0141	0241	0341	1,500	20	100
CKR04BX182K_	0042	0142	0242	0342	1,800	10	100
CKR04BX222K_	0043	0143	0243	0343	2,200	10	100
CKR04BX222M_	0044	0144	0244	0344	2,200	20	100
CKR04BX272K_	0045	0145	0245	0345	2,700	10	100
CKR04BX332K_	0046	0146	0246	0346	3,300	10	100
CKR04BX332M_	0047	0147	0247	0347	3,300	20	100
CKR04BX392K_	0048	0148	0248	0348	3,900	10	100
CKR04BX472K_	0049	0149	0249	0349	4,700	10	100
CKR04BX472M_	0050	0150	0250	0350	4,700	20	100
CKR04BX562K_	0051	0151	0251	0351	5,600	10	100
CKR04BX682K_	0052	0152	0252	0352	6,800	10	100
CKR04BX682M_	0053	0153	0253	0353	6,800	20	100
CKR04BX822K_	0054	0154	0254	0354	8,200	10	100
CKR04BX103K_	0055	0155	0255	0355	10,000	10	100
CKR04BX103M_	0056	0156	0256	0356	10,000	20	100
CKR04BX123K_	0057	0157	0257	0357	12,000	10	50
CKR04BX153K_	0058	0158	0258	0358	15,000	10	50
CKR04BX153M_	0059	0159	0259	0359	15,000	20	50
CKR04BX183K_	0060	0160	0260	0360	18,000	10	50
CKR04BX223K_	0061	0161	0261	0361	22,000	10	50
CKR04BX223M_	0062	0162	0262	0362	22,000	20	50
CKR04BX273K_	0063	0163	0263	0363	27,000	10	50
CKR04BX333K_	0064	0164	0264	0364	33,000	10	50
CKR04BX333M_	0065	0165	0265	0365	33,000	20	50
CKR04BX393K_	0066	0166	0266	0366	39,000	10	50
CKR04BX473K_	0067	0167	0267	0367	47,000	10	50
CKR04BX473M_	0068	0168	0268	0368	47,000	20	50
CKR04BX563K_	0069	0169	0269	0369	56,000	10	50
CKR04BX683K_	0070	0170	0270	0370	68,000	10	50
CKR04BX683M_	0071	0171	0271	0371	68,000	20	50
CKR04BX823K_	0072	0172	0272	0372	82,000	10	50
CKR04BX104K_	0073	0173	0273	0373	100,000	10	50
CKR04BX104M_	0074	0174	0274	0374	100,000	20	50

— Add appropriate failure rate level letter (M, P, R or S)



Military Ceramic Leaded Capacitors



MIL-PRF-39014/01, /02, /20, /23 - Radial Leads

MILITARY DASH NUMBER IDENTIFICATION CKR05 TO MIL-PRF-39014/01 (Dash Number From Table)

Military Type Designation	Failure Rate Level (%/1,000 Hours)				Capacitance (pF)	Capacitance Tolerance ±Percent	WVDC
	1.0 (M)	0.1 (P)	0.01 (R)	0.001 (S)			
CKR05 (BX)							
CKR05BX100K_	1201	1241	1281	1321	10	10	200
CKR05BX100M_	1202	1242	1282	1322	10	20	200
CKR05BX120K_	1203	1243	1283	1323	12	10	200
CKR05BX150K_	1204	1244	1284	1324	15	10	200
CKR05BX150M_	1205	1245	1285	1325	15	20	200
CKR05BX180K_	1206	1246	1286	1326	18	10	200
CKR05BX220K_	1207	1247	1287	1327	22	10	200
CKR05BX220M_	1208	1248	1288	1328	22	20	200
CKR05BX270K_	1209	1249	1289	1329	27	10	200
CKR05BX330K_	1210	1250	1290	1330	33	10	200
CKR05BX330M_	1211	1251	1291	1331	33	20	200
CKR05BX390K_	1212	1252	1292	1332	39	10	200
CKR05BX470K_	1213	1253	1293	1333	47	10	200
CKR05BX470M_	1214	1254	1294	1334	47	20	200
CKR05BX560K_	1215	1255	1295	1335	56	10	200
CKR05BX680K_	1216	1256	1296	1336	68	10	200
CKR05BX680M_	1217	1257	1297	1337	68	20	200
CKR05BX820K_	1218	1258	1298	1338	82	10	200
CKR05BX101K_	1219	1259	1299	1339	100	10	200
CKR05BX101M_	1220	1260	1300	1340	100	20	200
CKR05BX121K_	1221	1261	1301	1341	120	10	200
CKR05BX151K_	1222	1262	1302	1342	150	10	200
CKR05BX151M_	1223	1263	1303	1343	150	20	200
CKR05BX181K_	1224	1264	1304	1344	180	10	200
CKR05BX221K_	1225	1265	1305	1345	220	10	200
CKR05BX221M_	1226	1266	1306	1346	220	20	200
CKR05BX271K_	1227	1267	1307	1347	270	10	200
CKR05BX331K_	1228	1268	1308	1348	330	10	200
CKR05BX331M_	1229	1269	1309	1349	330	20	200
CKR05BX391K_	1230	1270	1310	1350	390	10	200
CKR05BX471K_	1231	1271	1311	1351	470	10	200
CKR05BX471M_	1232	1272	1312	1352	470	20	200
CKR05BX561K_	1233	1273	1313	1353	560	10	200
CKR05BX681K_	1234	1274	1314	1354	680	10	200
CKR05BX681M_	1235	1275	1315	1355	680	20	200
CKR05BX821K_	1236	1276	1316	1356	820	10	200
CKR05BX102K_	1237	1277	1317	1357	1,000	10	200
CKR05BX102M_	1238	1278	1318	1358	1,000	20	200
CKR05BX122K_	1239	1279	1319	1359	1,200	10	100
CKR05BX152K_	1240	1280	1320	1360	1,500	10	100
CKR05BX152M_	1441	1481	1521	1561	1,500	20	100
CKR05BX182K_	1442	1482	1522	1562	1,800	10	100
CKR05BX222K_	1443	1483	1523	1563	2,200	10	100
CKR05BX222M_	1444	1484	1524	1564	2,200	20	100
CKR05BX272K_	1445	1485	1525	1565	2,700	10	100
CKR05BX332K_	1446	1486	1526	1566	3,300	10	100
CKR05BX332M_	1447	1487	1527	1567	3,300	20	100
CKR05BX392K_	1448	1488	1528	1568	3,900	10	100
CKR05BX472K_	1449	1489	1529	1569	4,700	10	100
CKR05BX472M_	1450	1490	1530	1570	4,700	20	100
CKR05BX562K_	1451	1491	1531	1571	5,600	10	100
CKR05BX682K_	1452	1492	1532	1572	6,800	10	100
CKR05BX682M_	1453	1493	1533	1573	6,800	20	100
CKR05BX822K_	1454	1494	1534	1574	8,200	10	100
CKR05BX103K_	1455	1495	1535	1575	10,000	10	100
CKR05BX103M_	1456	1496	1536	1576	10,000	20	100
CKR05BX123K_	1457	1497	1537	1577	12,000	10	50
CKR05BX153K_	1458	1498	1538	1578	15,000	10	50
CKR05BX153M_	1459	1499	1539	1579	15,000	20	50
CKR05BX183K_	1460	1500	1540	1580	18,000	10	50
CKR05BX223K_	1461	1501	1541	1581	22,000	10	50
CKR05BX223M_	1462	1502	1542	1582	22,000	20	50
CKR05BX273K_	1463	1503	1543	1583	27,000	10	50
CKR05BX333K_	1464	1504	1544	1584	33,000	10	50
CKR05BX333M_	1465	1505	1545	1585	33,000	20	50
CKR05BX393K_	1466	1506	1546	1586	39,000	10	50
CKR05BX473K_	1467	1507	1547	1587	47,000	10	50
CKR05BX473M_	1468	1508	1548	1588	47,000	20	50
CKR05BX563K_	1469	1509	1549	1589	56,000	10	50
CKR05BX683K_	1470	1510	1550	1590	68,000	10	50
CKR05BX683M_	1471	1511	1551	1591	68,000	20	50
CKR05BX823K_	1472	1512	1552	1592	82,000	10	50
CKR05BX104K_	1473	1513	1553	1593	100,000	10	50
CKR05BX104M_	1474	1514	1554	1594	100,000	20	50

↳ Add appropriate failure rate level letter (M, P, R or S)



Military Ceramic Leaded Capacitors



MIL-PRF-39014/01, /02, /20, /23 - Radial Leads

MILITARY DASH NUMBER IDENTIFICATION CKR06 TO MIL-PRF-39014/02 (Dash Number From Table)

Military Type Designation	Failure Rate Level (%/1,000 Hours)				Capacitance (pF)	Capacitance Tolerance ±Percent	WVDC
	1.0 (M)	0.1 (P)	0.01 (R)	0.001 (S)			
CKR06 (BX)							
CKR06BX122K_	1201	1241	1281	1321	1200	10	200
CKR06BX152K_	1202	1242	1282	1322	1500	10	200
CKR06BX152M_	1203	1243	1283	1323	1500	20	200
CKR06BX182K_	1204	1244	1284	1324	1800	10	200
CKR06BX222K_	1206	1246	1286	1326	2200	10	200
CKR06BX222M_	1207	1247	1287	1327	2200	20	200
CKR06BX272K_	1208	1248	1288	1328	2700	10	200
CKR06BX332K_	1209	1249	1289	1329	3300	10	200
CKR06BX332M_	1210	1250	1290	1330	3300	20	200
CKR06BX392K_	1211	1251	1291	1331	3900	10	200
CKR06BX472K_	1212	1252	1292	1332	4700	10	200
CKR06BX472M_	1213	1253	1293	1333	4700	20	200
CKR06BX562K_	1214	1254	1294	1334	5600	10	200
CKR06BX682K_	1215	1255	1295	1335	6800	10	200
CKR06BX682M_	1216	1256	1296	1336	6800	20	200
CKR06BX822K_	1217	1257	1297	1337	8200	10	200
CKR06BX103K_	1218	1258	1298	1338	10,000	10	200
CKR06BX103M_	1219	1259	1299	1339	10,000	20	200
CKR06BX123K_	1231	1271	1311	1351	12,000	10	100
CKR06BX153K_	1220	1260	1300	1340	15,000	10	100
CKR06BX183K_	1221	1261	1301	1341	18,000	10	100
CKR06BX223K_	1222	1262	1302	1342	22,000	10	100
CKR06BX273K_	1232	1272	1312	1352	27,000	10	100
CKR06BX333K_	1223	1263	1303	1343	33,000	10	100
CKR06BX393K_	1224	1264	1304	1344	39,000	10	100
CKR06BX473K_	1225	1265	1305	1345	47,000	10	100
CKR06BX563K_	1226	1266	1306	1346	56,000	10	100
CKR06BX683K_	1227	1267	1307	1347	68,000	10	100
CKR06BX823K_	1229	1269	1309	1349	82,000	10	100
CKR06BX104K_	1230	1270	1310	1350	100,000	10	100
CKR06BX124K_	1233	1273	1313	1353	120,000	10	50
CKR06BX154K_	1234	1274	1314	1354	150,000	10	50
CKR06BX184K_	1235	1275	1315	1355	180,000	10	50
CKR06BX224K_	1236	1276	1316	1356	220,000	10	50
CKR06BX274K_	1237	1277	1317	1357	270,000	10	50
CKR06BX334K_	1238	1278	1318	1358	330,000	10	50
CKR06BX394K_	1239	1279	1319	1359	390,000	10	50
CKR06BX474K_	1240	1280	1320	1360	470,000	10	50
CKR06BX564K_	1404	1408	1412	1416	560,000	10	50
CKR06BX684K_	1405	1409	1413	1417	680,000	10	50
CKR06BX824K_	1406	1410	1414	1418	820,000	10	50
CKR06BX105K_	1407	1411	1415	1419	1,000,000	10	50

— Add appropriate failure rate level letter (M, P, R or S)

CKR08 TO MIL-PRF-39014/20 (Dash Number From Table)

Military Type Designation	Failure Rate Level (%/1,000 Hours)	Capacitance (pF)	Capacitance Tolerance ±Percent	WVDC
	1.0 (M)			
CKR08 (BX)				
CKR08BX125K_	0104	1,200,000	10	50
CKR08BX155K_	0105	1,500,000	10	50
CKR08BX205K_	0106	2,000,000	10	50

— Add appropriate failure rate level letter (M)

Military Ceramic Leaded Capacitors



MIL-PRF-39014/05 - Axial Leads

HOW TO ORDER

Military Type Designation: Styles CKR11, CKR12, CKR14, CKR15, CKR16

Dash Number Option: MIL-PRF-39014/05 (Add Appropriate Dash Number)

CKR11

Style

BX

Voltage-Temperature Limits

103

Capacitance Code

K

Capacitance Tolerance

S

Military Failure Rate

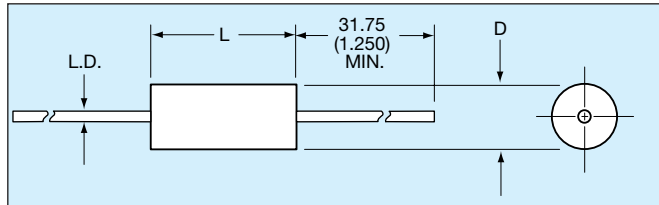

MIL PART NO. CODES

Style: **CK** = General purpose, ceramic dielectric, fixed capacitors.
R = Established Reliability parts.
11 = Remaining two numbers identify shape and dimension.

Voltage-Temperature Limits:

First letter identifies temperature range. B = -55°C to +125°C

Second letter identifies voltage-temperature coefficient.

Capacitance Change with Reference to 25°C		
Second Letter	No Voltage	Rated Voltage
R	+15, -15%	+15, -40%
X	+15, -15%	+15, -25%

Fig. Fig. Capacitance and Multiplier:

First two digits are the significant figures of capacitance. Third digit indicates the additional number of zeros. For example, order 10,000 pF as 103.

Capacitance Tolerances: K = ±10%, M = ±20%

Military Failure Rate: M = 1% per 1000 hours
 P = 0.1% per 1000 hours
 R = 0.01% per 1000 hours
 S = 0.001% per 1000 hours

Note: AVX reserves the right to substitute a lower failure rate part per MIL-PRF-39014/5E. Substitutability for failure rate levels shall be as follows:

Failure Rate Level	Will Replace Failure Rate Level
S (STD) (X-ray)	R, P, M, L
R (STD) (No X-ray)	P, M, L
P	M, L
M	L

PACKAGING REQUIREMENTS

Packaging: Bulk

CKR11, 12, & 14 100 pcs per bag
 CKR15 & 16 50 pcs per bag

Tape & Reel

CKR11, 12 5000 pcs per reel
 CKR14 3000 pcs per reel
 CKR15 950 pcs per reel
 CKR16 650 pcs per reel

SIZE SPECIFICATIONS millimeters (inches)

Per Mil Spec	Case Size		
	Length (L)	Diameter (D)	Lead Diameter (L.D.)
MIL-PRF-39014			
CKR11	4.07±.25 (0.160±0.010)	2.29±.25 (0.090±0.010)	.48±.05 (0.019±0.002)
CKR12	6.35±.25 (0.250±0.010)	2.29±.25 (0.090±0.010)	.48±.25 (0.019±0.002)
CKR14	9.91±.25 (0.390±0.010)	3.56±.25 (0.140±0.010)	.63±.25 (0.025±0.002)
CKR15	12.7±.51 (0.500±0.020)	6.35±.38 (0.250±0.015)	.63±.05 (0.025±0.002)
CKR16	17.53±.51 (0.690±0.020)	8.89±.51 (0.350±0.010)	.63±.05 (0.025±0.002)

MARKING

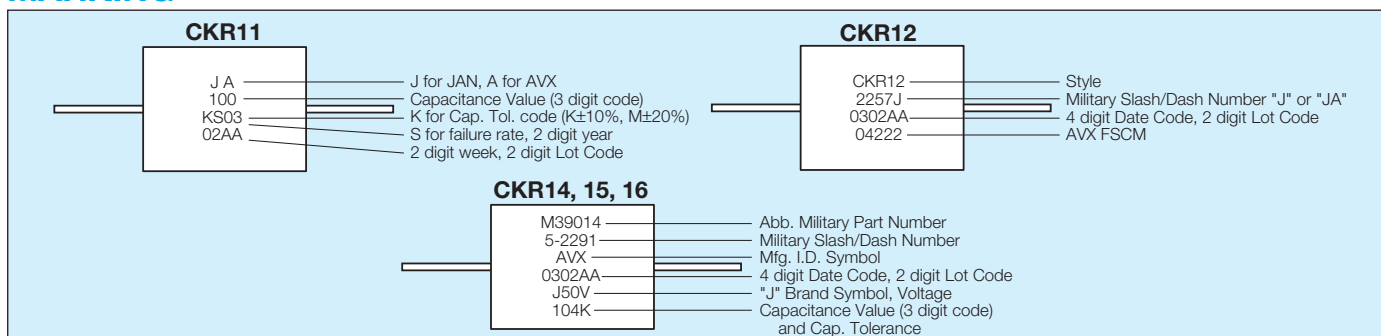

Military Ceramic Leaded Capacitors



MIL-PRF-39014/05 - Axial Leads

MILITARY DASH NUMBER IDENTIFICATION CKR11/12/14/15/16 TO MIL-PRF-39014/05 (Dash Number From Table)

Military Type Designation	Failure Rate Level (%/1,000 Hours)				Cap. (pF)	Cap. Tolerance ±Percent	WVDC
	1.0 (M)	0.1 (P)	0.01 (R)	0.001 (S)			
CKR11 (BX)							
CKR11BX100K	2601	2801	2001	2201	10	10	100
CKR11BX100M	2602	2802	2002	2202	10	20	100
CKR11BX120K	2603	2803	2003	2203	12	10	100
CKR11BX150K	2604	2804	2004	2204	15	10	100
CKR11BX150M	2605	2805	2005	2205	15	20	100
CKR11BX180K	2606	2806	2006	2206	18	10	100
CKR11BX220K	2607	2807	2007	2207	22	10	100
CKR11BX220M	2608	2808	2008	2208	22	20	100
CKR11BX270K	2609	2809	2009	2209	27	10	100
CKR11BX330K	2610	2810	2010	2210	33	10	100
CKR11BX330M	2611	2811	2011	2211	33	20	100
CKR11BX390K	2612	2812	2012	2212	39	10	100
CKR11BX470K	2613	2813	2013	2213	47	10	100
CKR11BX470M	2614	2814	2014	2214	47	20	100
CKR11BX560K	2615	2815	2015	2215	56	10	100
CKR11BX680K	2616	2816	2016	2216	68	10	100
CKR11BX680M	2617	2817	2017	2217	68	20	100
CKR11BX820K	2618	2818	2018	2218	82	10	100
CKR11BX101K	2619	2819	2019	2219	100	10	100
CKR11BX101M	2620	2820	2020	2220	100	20	100
CKR11BX121K	2621	2821	2021	2221	120	10	100
CKR11BX151K	2622	2822	2022	2222	150	10	100
CKR11BX151M	2623	2823	2023	2223	150	20	100
CKR11BX181K	2624	2824	2024	2224	180	10	100
CKR11BX221K	2625	2825	2025	2225	220	10	100
CKR11BX221M	2626	2826	2026	2226	220	20	100
CKR11BX271K	2627	2827	2027	2227	270	10	100
CKR11BX331K	2628	2828	2028	2228	330	10	100
CKR11BX331M	2629	2829	2029	2229	330	20	100
CKR11BX391K	2630	2830	2030	2230	390	10	100
CKR11BX471K	2631	2831	2031	2231	470	10	100
CKR11BX471M	2632	2832	2032	2232	470	20	100
CKR11BX561K	2633	2833	2033	2233	560	10	100
CKR11BX681K	2634	2834	2034	2234	680	10	100
CKR11BX681M	2635	2835	2035	2235	680	20	100
CKR11BX821K	2636	2836	2036	2236	820	10	100
CKR11BX102K	2637	2837	2037	2237	1000	10	100
CKR11BX102M	2638	2838	2038	2238	1000	20	100
CKR11BX122K	2639	2839	2039	2239	1200	10	100
CKR11BX152K	2640	2840	2040	2240	1500	10	100
CKR11BX152M	2641	2841	2041	2241	1500	20	100
CKR11BX182K	2642	2842	2042	2242	1800	10	100
CKR11BX222K	2643	2843	2043	2243	2200	10	100
CKR11BX222M	2644	2844	2044	2244	2200	20	100
CKR11BX272K	2645	2845	2045	2245	2700	10	100
CKR11BX332K	2646	2846	2046	2246	3300	10	100
CKR11BX332M	2647	2847	2047	2247	3300	20	100
CKR11BX392K	2648	2848	2048	2248	3900	10	100
CKR11BX472K	2649	2849	2049	2249	4700	10	100
CKR11BX472M	2650	2850	2050	2250	4700	20	100
CKR11BX562K	2651	2851	2051	2251	5600	10	50
CKR11BX682K	2652	2852	2052	2252	6800	10	50
CKR11BX682M	2653	2853	2053	2253	6800	20	50
CKR11BX822K	2654	2854	2054	2254	8200	10	50
CKR11BX103K	2655	2855	2055	2255	10,000	10	50
CKR11BX103M	2656	2856	2056	2256	10,000	20	50
CKR12 (BX)							
CKR12BX562K	2657	2857	2057	2257	5600	10	100
CKR12BX682K	2658	2858	2058	2258	6800	10	100
CKR12BX682M	2659	2859	2059	2259	6800	20	100
CKR12BX822K	2660	2860	2060	2260	8200	10	100
CKR12BX103K	2661	2861	2061	2261	10,000	10	100
CKR12BX103M	2662	2862	2062	2262	10,000	20	100
CKR12BX123K	2663	2863	2063	2263	12,000	10	50
CKR12BX153K	2664	2864	2064	2264	15,000	10	50
CKR12BX153M	2665	2865	2065	2265	15,000	20	50
CKR12BX183K	2666	2866	2066	2266	18,000	10	50
CKR12BX223K	2667	2867	2067	2267	22,000	10	50
CKR12BX223M	2668	2868	2068	2268	22,000	20	50
CKR12BX273K	2669	2869	2069	2269	27,000	10	50
CKR12BX333K	2670	2870	2070	2270	33,000	10	50
CKR12BX333M	2671	2871	2071	2271	33,000	20	50
CKR12BX393K	2672	2872	2072	2272	39,000	10	50
CKR12BX473K	2673	2873	2073	2273	47,000	10	50
CKR12BX473M	2674	2874	2074	2274	47,000	20	50

_____ Add appropriate failure rate level letter (M, P, R or S)

Military Type Designation	Failure Rate Level (%/1,000 Hours)				Cap. (pF)	Cap. Tolerance ±Percent	WVDC
	1.0 (M)	0.1 (P)	0.01 (R)	0.001 (S)			
CKR14 (BX)							
CKR14BX123K	2675	2875	2075	2275	12,000	10	100
CKR14BX153K	2676	2876	2076	2276	15,000	10	100
CKR14BX153M	2677	2877	2077	2277	15,000	20	100
CKR14BX183K	2678	2878	2078	2278	18,000	10	100
CKR14BX223K	2679	2879	2079	2279	22,000	10	100
CKR14BX223M	2680	2880	2080	2280	22,000	20	100
CKR14BX273K	2681	2881	2081	2281	27,000	10	100
CKR14BX333K	2682	2882	2082	2282	33,000	10	100
CKR14BX333M	2683	2883	2083	2283	33,000	20	100
CKR14BX393K	2684	2884	2084	2284	39,000	10	100
CKR14BX473K	2685	2885	2085	2285	47,000	10	100
CKR14BX473M	2686	2886	2086	2286	47,000	20	100
CKR14BX563K	2687	2887	2087	2287	56,000	10	50
CKR14BX683K	2688	2888	2088	2288	68,000	10	50
CKR14BX683M	2689	2889	2089	2289	68,000	20	50
CKR14BX823K	2690	2890	2090	2290	82,000	10	50
CKR14BX104K	2691	2891	2091	2291	100,000	10	50
CKR14BX104M	2692	2892	2092	2292	100,000	20	50
CKR14 (BR)							
CKR14BR563K	2693	2893	2093	2293	56,000	10	100
CKR14BR683K	2694	2894	2094	2294	68,000	10	100
CKR14BR683M	2695	2895	2095	2295	68,000	20	100
CKR14BR823K	2696	2896	2096	2296	82,000	10	100
CKR14BR104K	2697	2897	2097	2297	100,000	10	100
CKR14BR104M	2698	2898	2098	2298	100,000	20	100
CKR14BR124K	2699	2899	2099	2299	120,000	10	50
CKR14BR154K	2700	2900	2100	2300	150,000	10	50
CKR14BR154M	2701	2901	2101	2301	150,000	20	50
CKR14BR184K	2702	2902	2102	2302	180,000	10	50
CKR14BR224K	2703	2903	2103	2303	220,000	10	50
CKR14BR224M	2704	2904	2104	2304	220,000	20	50
CKR14BR274K	2705	2905	2105	2305	270,000	10	50
CKR15 (BX)							
CKR15BX563K	2706	2906	2106	2306	56,000	10	100
CKR15BX683K	2707	2907	2107	2307	68,000	10	100
CKR15BX683M	2708	2908	2108	2308	68,000	20	100
CKR15BX823K	2709	2909	2109	2309	82,000	10	100
CKR15BX104K	2710	2910	2110	2310	100,000	10	100
CKR15BX104M	2711	2911	2111	2311	100,000	20	100
CKR15 (BR)							
CKR15BR124K	2712	2912	2112	2312	120,000	10	100
CKR15BR154K	2713	2913	2113	2313	150,000	10	100
CKR15BR154M	2714	2914	2114	2314	150,000	20	100
CKR15BR184K	2715	2915	2115	2315	180,000	10	100
CKR15BR224K	2716	2916	2116	2316	220,000	10	100
CKR15BR224M	2717	2917	2117	2317	220,000	20	100
CKR15BR274K	2718	2918	2118	2318	270,000	10	100
CKR15BR334K	2719	2919	2119	2319	330,000	10	100
CKR15BR334M	2720	2920	2120	2320	330,000	20	100
CKR15BR474K	2721	2921	2121	2321	470,000	10	50
CKR15BR474M	2722	2922	2122	2322	470,000	20	50
CKR15BR684K	2723	2923	2123	2323	680,000	10	50
CKR15BR684M	2724	2924	2124	2324	680,000	20	50
CKR15BR105K	2725	2925	2125	2325	1,000,000	10	50
CKR15BR105M	2726	2926	2126	2326	1,000,000	20	50
CKR16 (BR)							
CKR16BR474K	2727	2927	2127	2327	470,000	10	100
CKR16BR474M	2728	2928	2128	2328	470,000	20	100
CKR16BR684K	2729	2929	2129	2329	680,000	10	100
CKR16BR684M	2730	2930	2130	2330	680,000	20	100
CKR16BR105K	2731	2931	2131	2331	1,000,000	10	100
CKR16BR105M	2732	2932	2132	2332	1,000,000	20	100
CKR16BR225K	2733	2933	2133	2333	2,200,000	10	50
CKR16BR225M	2734	2934	2134	2334	2,200,000	20	50
CKR16BR335K	2735	2935	2135	2335	3,300,000	10	50
CKR16BR335M	2736	2936	2136	2336	3,300,000	20	50

_____ Add appropriate failure rate level letter (M, P, R or S)



Military Ceramic Leaded Capacitors



MIL-PRF-39014/22 - 2 Pin DIP

HOW TO ORDER

Military Type Designation: Styles CKR22, CKR23, CKR24

Dash Number Option: MIL-PRF-39014/22 (Add Appropriate Dash Number)

CKR22

Style

BX

Voltage-Temperature Limits

104

Capacitance Code

K

Capacitance Tolerance

S

Military Failure Rate

MIL PART NO. CODES

Style: **CK** = General purpose, ceramic dielectric, fixed capacitors.

R = Established Reliability parts.

22 = Remaining two numbers identify shape and dimension.

Voltage-Temperature Limits:

First letter identifies temperature range.

B = -55°C to +125°C

C = -55°C to +150°C

Second letter identifies voltage-temperature coefficient.

Capacitance Change with Reference to 25°C

Second Letter	No Voltage	Rated Voltage
G	+30, -30ppm	+30, -30ppm
H	+60, -60ppm	+60, -60ppm
R	+15, -15%	+15, -40%
X	+15, -15%	+15, -25%

Sig. Fig. Capacitance and Multiplier:

First two digits are the significant figures of capacitance. Third digit indicates the additional number of zeros. For example, order 100,000 pF as 104. (For values below 10 pF, use "R" in place of decimal point, e.g., 1R5 = 1.5 pF).

Capacitance Tolerances: D = ± 0.5 pF, F = $\pm 1\%$, J = $\pm 5\%$, K = $\pm 10\%$, M = $\pm 20\%$

Military Failure Rate: M = 1% per 1000 hours
 P = 0.1% per 1000 hours
 R = 0.01% per 1000 hours
 S = 0.001% per 1000 hours

Note: AVX reserves the right to substitute a lower failure rate part per MIL-PRF-39014. Substitutability for failure rate levels shall be as follows:

Failure Rate Level	Will Replace Failure Rate Level
S (STD) (X-ray)	R, P, M, L
R (STD) (No X-ray)	P, M, L
P	M, L
M	L

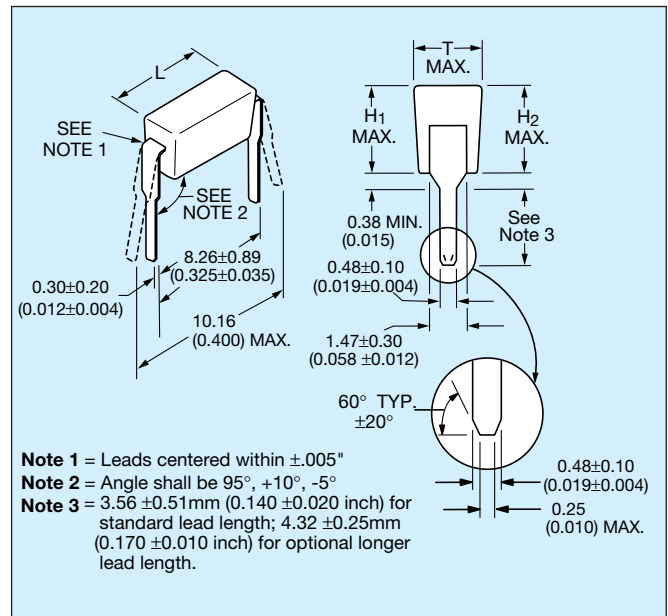

PACKAGING REQUIREMENTS

Packaging: 200 pcs/slide pack. See page 30.

SIZE SPECIFICATIONS millimeters (inches)

MIL-PRF-39014	Length (L)	Height (H ₁)	Height (H ₂)	Thickness
CKR22	6.60 (0.260 \pm 0.020)	3.25 (0.128 \pm 0.007)	4.45 max. (0.175)	2.34 (0.092 \pm 0.006)
CKR23	6.60 (0.260 \pm 0.020)	3.94 (0.155 \pm 0.007)	4.45 max. (0.195)	2.34 (0.092 \pm 0.006)
CKR24	6.60 (0.260 \pm 0.020)	7.19 (0.283 \pm 0.007)	8.13 max. (0.320)	2.34 (0.092 \pm 0.006)

Military Ceramic Leaded Capacitors



MIL-PRF-39014/22 - 2 Pin DIP

MILITARY DASH NUMBER IDENTIFICATION CKR22 TO MIL-PRF-39014/22 (Dash Number From Table)

Military Type Designation	Failure Rate Level (%/1,000 Hours)								Capacitance (pF)	Capacitance Tolerance	WVDC
	Standard Lead Length				Optional Longer Lead Length						
	1.0 (M)	0.1 (P)	0.01 (R)	0.001 (S)	1.0 (M)	0.1 (P)	0.01 (R)	0.001 (S)			
Style CKR22, Voltage-temperature limits of 0 ± 60 ppm/°C											
CKR22CH1R0D_	0001	0301	0601	0901	3001	3301	3601	3901	1.0	D	200
CKR22CH1R2D_	0004	0304	0604	0904	3004	3304	3604	3904	1.2	D	
CKR22CH1R5D_	0007	0307	0607	0907	3007	3307	3607	3907	1.5	D	
CKR22CH1R8D_	0010	0310	0610	0910	3010	3310	3610	3910	1.8	D	
CKR22CH2R2D_	0013	0313	0613	0913	3013	3313	3613	3913	2.2	D	200
CKR22CH2R7D_	0016	0316	0616	0916	3016	3316	3616	3916	2.7	D	
CKR22CH3R3D_	0019	0319	0619	0919	3019	3319	3619	3919	3.3	D	
CKR22CH3R9D_	0022	0322	0622	0922	3022	3322	3622	3922	3.9	D	
CKR22CH4R7D_	0025	0325	0625	0925	3025	3325	3625	3925	4.7	D	
CKR22CH5R6D_	0028	0328	0628	0928	3028	3328	3628	3928	5.6	D	
CKR22CH6R8D_	0031	0331	0631	0931	3031	3331	3631	3931	6.8	D	
CKR22CH8R2D_	0034	0334	0634	0934	3034	3334	3634	3934	8.2	D	
CKR22CH100D_	0037	0337	0637	0937	3037	3337	3637	3937	10	D	
CKR22CH100J_	0038	0338	0638	0938	3038	3338	3638	3938	10	J	
CKR22CH100K_	0039	0339	0639	0939	3039	3339	3639	3939	10	K	
CKR22CH120D_	0040	0340	0640	0940	3040	3340	3640	3940	12	D	
CKR22CH120J_	0041	0341	0641	0941	3041	3341	3641	3941	12	J	
CKR22CH120K_	0042	0342	0642	0942	3042	3342	3642	3942	12	K	
CKR22CH150D_	0043	0343	0643	0943	3043	3343	3643	3943	15	D	
CKR22CH150J_	0044	0344	0644	0944	3044	3344	3644	3944	15	J	
CKR22CH150K_	0045	0345	0645	0945	3045	3345	3645	3945	15	K	
CKR22CH180D_	0046	0346	0646	0946	3046	3346	3646	3946	18	D	
CKR22CH180J_	0047	0347	0647	0947	3047	3347	3647	3947	18	J	
CKR22CH180K_	0048	0348	0648	0948	3048	3348	3648	3948	18	K	
Style CKR22, Voltage-temperature limits of ±30 ppm/°C											
CKR22CG220D_	0049	0349	0649	0949	3049	3349	3649	3949	22	D	200
CKR22CG220J_	0050	0350	0650	0950	3050	3350	3650	3950	22	J	
CKR22CG220K_	0051	0351	0651	0951	3051	3351	3651	3951	22	K	
CKR22CG270D_	0052	0352	0652	0952	3052	3352	3652	3952	27	D	
CKR22CG270J_	0053	0353	0653	0953	3053	3353	3653	3953	27	J	
CKR22CG270K_	0054	0354	0654	0954	3054	3354	3654	3954	27	K	
CKR22CG330D_	0055	0355	0655	0955	3055	3355	3655	3955	33	D	
CKR22CG330J_	0056	0356	0656	0956	3056	3356	3656	3956	33	J	
CKR22CG330K_	0057	0357	0657	0957	3057	3357	3657	3957	33	K	
CKR22CG390D_	0058	0358	0658	0958	3058	3358	3658	3958	39	D	
CKR22CG390J_	0059	0359	0659	0959	3059	3359	3659	3959	39	J	
CKR22CG390K_	0060	0360	0660	0960	3060	3360	3660	3960	39	K	
CKR22CG470D_	0061	0361	0661	0961	3061	3361	3661	3961	47	D	
CKR22CG470J_	0062	0362	0662	0962	3062	3362	3662	3962	47	J	
CKR22CG470K_	0063	0363	0663	0963	3063	3363	3663	3963	47	K	
CKR22CG560D_	0064	0364	0664	0964	3064	3364	3664	3964	56	D	
CKR22CG560J_	0065	0365	0665	0965	3065	3365	3665	3965	56	J	
CKR22CG560K_	0066	0366	0666	0966	3066	3366	3666	3966	56	K	
CKR22CG680F_	0067	0367	0667	0967	3067	3367	3667	3967	68	F	
CKR22CG680J_	0068	0368	0668	0968	3068	3368	3668	3968	68	J	
CKR22CG680K_	0069	0369	0669	0969	3069	3369	3669	3969	68	K	
CKR22CG820F_	0070	0370	0670	0970	3070	3370	3670	3970	82	F	
CKR22CG820J_	0071	0371	0671	0971	3071	3371	3671	3971	82	J	
CKR22CG820K_	0072	0372	0672	0972	3072	3372	3672	3972	82	K	
CKR22CG101F_	0073	0373	0673	0973	3073	3373	3673	3973	100	F	
CKR22CG101J_	0074	0374	0674	0974	3074	3374	3674	3974	100	J	
CKR22CG101K_	0075	0375	0675	0975	3075	3375	3675	3975	100	K	
CKR22CG121F_	0076	0376	0676	0976	3076	3376	3676	3976	120	F	
CKR22CG121J_	0077	0377	0677	0977	3077	3377	3677	3977	120	J	
CKR22CG121K_	0078	0378	0678	0978	3078	3378	3678	3978	120	K	
CKR22CG151F_	0079	0379	0679	0979	3079	3379	3679	3979	150	F	
CKR22CG151J_	0080	0380	0680	0980	3080	3380	3680	3980	150	J	
CKR22CG151K_	0081	0381	0681	0981	3081	3381	3681	3981	150	K	
CKR22CG181F_	0082	0382	0682	0982	3082	3382	3682	3982	180	F	
CKR22CG181J_	0083	0383	0683	0983	3083	3383	3683	3983	180	J	
CKR22CG181K_	0084	0384	0684	0984	3084	3384	3684	3984	180	K	
CKR22CG221F_	0085	0385	0685	0985	3085	3385	3685	3985	220	F	
CKR22CG221J_	0086	0386	0686	0986	3086	3386	3686	3986	220	J	
CKR22CG221K_	0087	0387	0687	0987	3087	3387	3687	3987	220	K	
CKR22CG271F_	0088	0388	0688	0988	3088	3388	3688	3988	270	F	
CKR22CG271J_	0089	0389	0689	0989	3089	3389	3689	3989	270	J	

Add appropriate failure rate level letter (M, P, R or S)



Military Ceramic Leaded Capacitors



MIL-PRF-39014/22 - 2 Pin DIP

MILITARY DASH NUMBER IDENTIFICATION CKR22 TO MIL-PRF-39014/22 (Dash Number From Table)

Military Type Designation	Failure Rate Level (%/1,000 Hours)								Capacitance (pF)	Capacitance Tolerance	WVDC	
	Standard Lead Length				Optional Longer Lead Length							
	1.0 (M)	0.1 (P)	0.01 (R)	0.001 (S)	1.0 (M)	0.1 (P)	0.01 (R)	0.001 (S)				
Style CKR22, Voltage-temperature limits of ±30 ppm/°C (continued)												
CKR22CG271K_	0090	0390	0690	0990	3090	3390	3690	3990	270	K	200	
CKR22CG331F_	0091	0391	0691	0991	3091	3391	3691	3991	330	F		
CKR22CG331J_	0092	0392	0692	0992	3092	3392	3692	3992	330	J		
CKR22CG331K_	0093	0393	0693	0993	3093	3393	3693	3993	330	K		
CKR22CG391F_	0094	0394	0694	0994	3094	3394	3694	3994	390	F		
CKR22CG391J_	0095	0395	0695	0995	3095	3395	3695	3995	390	J		
CKR22CG391K_	0096	0396	0696	0996	3096	3396	3696	3996	390	K		
CKR22CG471F_	0097	0397	0697	0997	3097	3397	3697	3997	470	F		
CKR22CG471J_	0098	0398	0698	0998	3098	3398	3698	3998	470	J		
CKR22CG471K_	0099	0399	0699	0999	3099	3399	3699	3999	470	K		
CKR22CG561F_	0100	0400	0700	1000	3100	3400	3700	4000	560	F		100
CKR22CG561J_	0101	0401	0701	1001	3101	3401	3701	4001	560	J		
CKR22CG561K_	0102	0402	0702	1002	3102	3402	3702	4002	560	K		
CKR22CG681F_	0103	0403	0703	1003	3103	3403	3703	4003	680	F		
CKR22CG681J_	0104	0404	0704	1004	3104	3404	3704	4004	680	J		
CKR22CG681K_	0105	0405	0705	1005	3105	3405	3705	4005	680	K		
CKR22CG821F_	0106	0406	0706	1006	3106	3406	3706	4006	820	F		
CKR22CG821J_	0107	0407	0707	1007	3107	3407	3707	4007	820	J		
CKR22CG821K_	0108	0408	0708	1008	3108	3408	3708	4008	820	K		
CKR22CG102F_	0109	0409	0709	1009	3109	3409	3709	4009	1000	F		
CKR22CG102J_	0110	0410	0710	1010	3110	3410	3710	4010	1000	J		
CKR22CG102K_	0111	0411	0711	1011	3111	3411	3711	4011	1000	K		
CKR22CG122F_	0112	0412	0712	1012	3112	3412	3712	4012	1200	F		
CKR22CG122J_	0113	0413	0713	1013	3113	3413	3713	4013	1200	J		
CKR22CG122K_	0114	0414	0714	1014	3114	3414	3714	4014	1200	K		
CKR22CG152F_	0115	0415	0715	1015	3115	3415	3715	4015	1500	F		
CKR22CG152J_	0116	0416	0716	1016	3116	3416	3716	4016	1500	J		
CKR22CG152K_	0117	0417	0717	1017	3117	3417	3717	4017	1500	K		
CKR22CG182F_	0118	0418	0718	1018	3118	3418	3718	4018	1800	F		
CKR22CG182J_	0119	0419	0719	1019	3119	3419	3719	4019	1800	J		
CKR22CG182K_	0120	0420	0720	1020	3120	3420	3720	4020	1800	K		
CKR22CG222F_	0121	0421	0721	1021	3121	3421	3721	4021	2200	F		
CKR22CG222J_	0122	0422	0722	1022	3122	3422	3722	4022	2200	J		
CKR22CG222K_	0123	0423	0723	1023	3123	3423	3723	4023	2200	K		
CKR22CG272F_	0124	0424	0724	1024	3124	3424	3724	4024	2700	F		
CKR22CG272J_	0125	0425	0725	1025	3125	3425	3725	4025	2700	J		
CKR22CG272K_	0126	0426	0726	1026	3126	3426	3726	4026	2700	K		
CKR22CG332F_	0127	0427	0727	1027	3127	3427	3727	4027	3300	F		
CKR22CG332J_	0128	0428	0728	1028	3128	3428	3728	4028	3300	J		
CKR22CG332K_	0129	0429	0729	1029	3129	3429	3729	4029	3300	K		
CKR22CG392F_	0130	0430	0730	1030	3130	3430	3730	4030	3900	F		
CKR22CG392J_	0131	0431	0731	1031	3131	3431	3731	4031	3900	J		
CKR22CG392K_	0132	0432	0732	1032	3132	3432	3732	4032	3900	K		
CKR22CG472F_	0133	0433	0733	1033	3133	3433	3733	4033	4700	F		
CKR22CG472J_	0134	0434	0734	1034	3134	3434	3734	4034	4700	J		
CKR22CG472K_	0135	0435	0735	1035	3135	3435	3735	4035	4700	K		
CKR22CG562F_	0136	0436	0736	1036	3136	3436	3736	4036	5600	F		
CKR22CG562J_	0137	0437	0737	1037	3137	3437	3737	4037	5600	J		
CKR22CG562K_	0138	0438	0738	1038	3138	3438	3738	4038	5600	K		
CKR22CG682F_	0139	0439	0739	1039	3139	3439	3739	4039	6800	F		
CKR22CG682J_	0140	0440	0740	1040	3140	3440	3740	4040	6800	J		
CKR22CG682K_	0141	0441	0741	1041	3141	3441	3741	4041	6800	K		
CKR22CG822F_	0142	0442	0742	1042	3142	3442	3742	4042	8200	F		
CKR22CG822J_	0143	0443	0743	1043	3143	3443	3743	4043	8200	J		
CKR22CG822K_	0144	0444	0744	1044	3144	3444	3744	4044	8200	K		
CKR22CG103F_	0145	0445	0745	1045	3145	3445	3745	4045	10,000	F		
CKR22CG103J_	0146	0446	0746	1046	3146	3446	3746	4046	10,000	J		
CKR22CG103K_	0147	0447	0747	1047	3147	3447	3747	4047	10,000	K		

— Add appropriate failure rate level letter (M, P, R or S)



Military Ceramic Leaded Capacitors



MIL-PRF-39014/22 - 2 Pin DIP

MILITARY DASH NUMBER IDENTIFICATION CKR22 TO MIL-PRF-39014/22 (Dash Number From Table)

Military Type Designation	Failure Rate Level (%/1,000 Hours)								Capacitance (pF)	Capacitance Tolerance	WVDC
	Standard Lead Length				Optional Longer Lead Length						
	1.0 (M)	0.1 (P)	0.01 (R)	0.001 (S)	1.0 (M)	0.1 (P)	0.01 (R)	0.001 (S)			
Style CKR22, Voltage-temperature limits of ±15% (+15%, -25% for Rated Voltage)											
CKR22BX271K_	0148	0448	0748	1048	3148	3448	3748	4048	270	K	200 ↓
CKR22BX331K_	0149	0449	0749	1049	3149	3449	3749	4049	330	K	
CKR22BX331M_	0150	0450	0750	1050	3150	3450	3750	4050	330	M	
CKR22BX391K_	0151	0451	0751	1051	3151	3451	3751	4051	390	K	
CKR22BX471K_	0152	0452	0752	1052	3152	3452	3752	4052	470	K	
CKR22BX471M_	0153	0453	0753	1053	3153	3453	3753	4053	470	M	
CKR22BX561K_	0154	0454	0754	1054	3154	3454	3754	4054	560	K	
CKR22BX681K_	0155	0455	0755	1055	3155	3455	3755	4055	680	K	
CKR22BX681M_	0156	0456	0756	1056	3156	3456	3756	4056	680	M	
CKR22BX821K_	0157	0457	0757	1057	3157	3457	3757	4057	820	K	
CKR22BX102K_	0158	0458	0758	1058	3158	3458	3758	4058	1,000	K	100 ↓
CKR22BX102M_	0159	0459	0759	1059	3159	3459	3759	4059	1,000	M	
CKR22BX122K_	0160	0460	0760	1060	3160	3460	3760	4060	1,200	K	
CKR22BX152K_	0161	0461	0761	1061	3161	3461	3761	4061	1,500	K	
CKR22BX152M_	0162	0462	0762	1062	3162	3462	3762	4062	1,500	M	
CKR22BX182K_	0163	0463	0763	1063	3163	3463	3763	4063	1,800	K	
CKR22BX222K_	0164	0464	0764	1064	3164	3464	3764	4064	2,200	K	
CKR22BX222M_	0165	0465	0765	1065	3165	3465	3765	4065	2,200	M	
CKR22BX272K_	0166	0466	0766	1066	3166	3466	3766	4066	2,700	K	
CKR22BX322K_	0167	0467	0767	1067	3167	3467	3767	4067	3,300	K	
CKR22BX332M_	0168	0468	0768	1068	3168	3468	3768	4068	3,300	M	100 ↓
CKR22BX392K_	0169	0469	0769	1069	3169	3469	3769	4069	3,900	K	
CKR22BX472K_	0170	0470	0770	1070	3170	3470	3770	4070	4,700	K	
CKR22BX472M_	0171	0471	0771	1071	3171	3471	3771	4071	4,700	M	
CKR22BX562K_	0172	0472	0772	1072	3172	3472	3772	4072	5,600	K	
CKR22BX682K_	0173	0473	0773	1073	3173	3473	3773	4073	6,800	K	
CKR22BX682M_	0174	0474	0774	1074	3174	3474	3774	4074	6,800	M	
CKR22BX822K_	0175	0475	0775	1075	3175	3475	3775	4075	8,200	K	
CKR22BX103K_	0176	0476	0776	1076	3176	3476	3776	4076	10,000	K	
CKR22BX103M_	0177	0477	0777	1077	3177	3477	3777	4077	10,000	M	
CKR22BX123K_	0178	0478	0778	1078	3178	3478	3778	4078	12,000	K	50 ↓
CKR22BX153K_	0179	0479	0779	1079	3179	3479	3779	4079	15,000	K	
CKR22BX153M_	0180	0480	0780	1080	3180	3480	3780	4080	15,000	M	
CKR22BX183K_	0181	0481	0781	1081	3181	3481	3781	4081	18,000	K	
CKR22BX223K_	0182	0482	0782	1082	3182	3482	3782	4082	22,000	K	
CKR22BX223M_	0183	0483	0783	1083	3183	3483	3783	4083	22,000	M	
CKR22BX273K_	0184	0484	0784	1084	3184	3484	3784	4084	27,000	K	
CKR22BX333K_	0185	0485	0785	1085	3185	3485	3785	4085	33,000	K	
CKR22BX333M_	0186	0486	0786	1086	3186	3486	3786	4086	33,000	M	
CKR22BX393K_	0187	0487	0787	1087	3187	3487	3787	4087	39,000	K	
CKR22BX473K_	0188	0488	0788	1088	3188	3488	3788	4088	47,000	K	
CKR22BX473M_	0189	0489	0789	1089	3189	3489	3789	4089	47,000	M	
CKR22BX563K_	0190	0490	0790	1090	3190	3490	3790	4090	56,000	K	
CKR22BX683K_	0191	0491	0791	1091	3191	3491	3791	4091	68,000	K	
CKR22BX683M_	0192	0492	0792	1092	3192	3492	3792	4092	68,000	M	
CKR22BX823K_	0193	0493	0793	1093	3193	3493	3793	4093	82,000	K	
CKR22BX104K_	0194	0494	0794	1094	3194	3494	3794	4094	100,000	K	
CKR22BX104M_	0195	0495	0795	1095	3195	3495	3795	4095	100,000	M	

Add appropriate failure rate level letter (M, P, R or S)



Military Ceramic Leaded Capacitors



MIL-PRF-39014/22 - 2 Pin DIP

MILITARY DASH NUMBER IDENTIFICATION CKR23/24 TO MIL-PRF-39014/22 (Dash Number From Table)

Military Type Designation	Failure Rate Level (%/1,000 Hours)								Cap. (pF)	Cap. Tol.	WV DC
	Standard Lead Length				Optional Longer Lead Length						
	1.0 (M)	0.1 (P)	0.01 (R)	0.001 (S)	1.0 (M)	0.1 (P)	0.01 (R)	0.001 (S)			
Style CKR23, Voltage-temperature limits of 0 ± 60 ppm/°C											
CKR23CG561F	0258	0558	0858	1158	3258	3558	3858	4158	560	F	200
CKR23CG561J	0259	0559	0859	1159	3259	3559	3859	4159	560	J	200
CKR23CG561K	0260	0560	0860	1160	3260	3560	3860	4160	560	K	200
CKR23CG681F	0261	0561	0861	1161	3261	3561	3861	4161	680	F	200
CKR23CG681J	0262	0562	0862	1162	3262	3562	3862	4162	680	J	200
CKR23CG681K	0263	0563	0863	1163	3263	3563	3863	4163	680	K	200
CKR23CG821F	0264	0564	0864	1164	3264	3564	3864	4164	820	F	200
CKR23CG821J	0265	0565	0865	1165	3265	3565	3865	4165	820	J	200
CKR23CG821K	0266	0566	0866	1166	3266	3566	3866	4166	820	K	200
CKR23CG102F	0267	0567	0867	1167	3267	3567	3867	4167	1,000	F	200
CKR23CG102J	0268	0568	0868	1168	3268	3568	3868	4168	1,000	J	200
CKR23CG102K	0269	0569	0869	1169	3269	3569	3869	4169	1,000	K	200
CKR23CG122F	0270	0570	0870	1170	3270	3570	3870	4170	1,200	F	200
CKR23CG122J	0271	0571	0871	1171	3271	3571	3871	4171	1,200	J	200
CKR23CG122K	0272	0572	0872	1172	3272	3572	3872	4172	1,200	K	200
CKR23CG272F	0273	0573	0873	1173	3273	3573	3873	4173	2,700	F	100
CKR23CG272J	0274	0574	0874	1174	3274	3574	3874	4174	2,700	J	100
CKR23CG272K	0275	0575	0875	1175	3275	3575	3875	4175	2,700	K	100
CKR23CG332F	0276	0576	0876	1176	3276	3576	3876	4176	3,300	F	100
CKR23CG332J	0277	0577	0877	1177	3277	3577	3877	4177	3,300	J	100
CKR23CG332K	0278	0578	0878	1178	3278	3578	3878	4178	3,300	K	100
CKR23CG472F	0279	0579	0879	1179	3279	3579	3879	4179	4,700	F	50
CKR23CG472J	0280	0580	0880	1180	3280	3580	3880	4180	4,700	J	50
CKR23CG472K	0281	0581	0881	1181	3281	3581	3881	4181	4,700	K	50
CKR23CG562F	0282	0582	0882	1182	3282	3582	3882	4182	5,600	F	50
CKR23CG562J	0283	0583	0883	1183	3283	3583	3883	4183	5,600	J	50
CKR23CG562K	0284	0584	0884	1184	3284	3584	3884	4184	5,600	K	50
CKR23CG682F	0285	0585	0885	1185	3285	3585	3885	4185	6,800	F	50
CKR23CG682J	0286	0586	0886	1186	3286	3586	3886	4186	6,800	J	50
CKR23CG682K	0287	0587	0887	1187	3287	3587	3887	4187	6,800	K	50
CKR23CG822F	0288	0588	0888	1188	3288	3588	3888	4188	8,200	F	50
CKR23CG822J	0289	0589	0889	1189	3289	3589	3889	4189	8,200	J	50
CKR23CG822K	0290	0590	0890	1190	3290	3590	3890	4190	8,200	K	50
CKR23CG103F	0291	0591	0891	1191	3291	3591	3891	4191	10,000	F	50
CKR23CG103J	0292	0592	0892	1192	3292	3592	3892	4192	10,000	J	50
CKR23CG103K	0293	0593	0893	1193	3293	3593	3893	4193	10,000	K	50
Style CKR23, Voltage-temperature limits of ±15% (+15%, -25% for Rated Voltage)											
CKR23BX102K	0196	0496	0796	1096	3196	3496	3796	4096	1,000	K	200
CKR23BX102M	0197	0497	0797	1097	3197	3497	3797	4097	1,000	M	200
CKR23BX122K	0198	0498	0798	1098	3198	3498	3798	4098	1,200	K	200
CKR23BX152K	0199	0499	0799	1099	3199	3499	3799	4099	1,500	K	200
CKR23BX152M	0200	0500	0800	1100	3200	3500	3800	4100	1,500	M	200
CKR23BX182K	0201	0501	0801	1101	3201	3501	3801	4101	1,800	K	200
CKR23BX222K	0202	0502	0802	1102	3202	3502	3802	4102	2,200	K	200
CKR23BX222M	0203	0503	0803	1103	3203	3503	3803	4103	2,200	M	200
CKR23BX272K	0204	0504	0804	1104	3204	3504	3804	4104	2,700	K	200
CKR23BX332K	0205	0505	0805	1105	3205	3505	3805	4105	3,300	K	200
CKR23BX332M	0206	0506	0806	1106	3206	3506	3806	4106	3,300	M	200
CKR23BX392K	0207	0507	0807	1107	3207	3507	3807	4107	3,900	K	200
CKR23BX472K	0208	0508	0808	1108	3208	3508	3808	4108	4,700	K	200
CKR23BX472M	0209	0509	0809	1109	3209	3509	3809	4109	4,700	M	200
CKR23BX562K	0210	0510	0810	1110	3210	3510	3810	4110	5,600	K	200
CKR23BX682K	0211	0511	0811	1111	3211	3511	3811	4111	6,800	K	200
CKR23BX682M	0212	0512	0812	1112	3212	3512	3812	4112	6,800	M	200
CKR23BX822K	0213	0513	0813	1113	3213	3513	3813	4113	8,200	K	200
CKR23BX103K	0214	0514	0814	1114	3214	3514	3814	4114	10,000	K	200
CKR23BX103M	0215	0515	0815	1115	3215	3515	3815	4115	10,000	M	200
CKR23BX123K	0216	0516	0816	1116	3216	3516	3816	4116	12,000	K	100
CKR23BX153K	0217	0517	0817	1117	3217	3517	3817	4117	15,000	K	100
CKR23BX153M	0218	0518	0818	1118	3218	3518	3818	4118	15,000	M	100
CKR23BX183K	0219	0519	0819	1119	3219	3519	3819	4119	18,000	K	100
CKR23BX223K	0220	0520	0820	1120	3220	3520	3820	4120	22,000	K	100
CKR23BX223M	0221	0521	0821	1121	3221	3521	3821	4121	22,000	M	100
CKR23BX273K	0222	0522	0822	1122	3222	3522	3822	4122	27,000	K	100
CKR23BX333K	0223	0523	0823	1123	3223	3523	3823	4123	33,000	K	100
CKR23BX333M	0224	0524	0824	1124	3224	3524	3824	4124	33,000	M	100
CKR23BX393K	0225	0525	0825	1125	3225	3525	3825	4125	39,000	K	100
CKR23BX473K	0226	0526	0826	1126	3226	3526	3826	4126	47,000	K	100
CKR23BX473M	0227	0527	0827	1127	3227	3527	3827	4127	47,000	M	100
CKR23BX563K	0228	0528	0828	1128	3228	3528	3828	4128	56,000	K	100
CKR23BX683K	0229	0529	0829	1129	3229	3529	3829	4129	68,000	K	100
CKR23BX683M	0230	0530	0830	1130	3230	3530	3830	4130	68,000	M	100
CKR23BX823K	0231	0531	0831	1131	3231	3531	3831	4131	82,000	K	100
CKR23BX104K	0232	0532	0832	1132	3232	3532	3832	4132	100,000	K	100
CKR23BX104M	0233	0533	0833	1133	3233	3533	3833	4133	100,000	M	100
CKR23BX124K	0234	0534	0834	1134	3234	3534	3834	4134	120,000	K	50
CKR23BX154K	0235	0535	0835	1135	3235	3535	3835	4135	150,000	K	50
CKR23BX154M	0236	0536	0836	1136	3236	3536	3836	4136	150,000	M	50
CKR23BX184K	0237	0537	0837	1137	3237	3537	3837	4137	180,000	K	50
CKR23BX224K	0238	0538	0838	1138	3238	3538	3838	4138	220,000	K	50
CKR23BX224M	0239	0539	0839	1139	3239	3539	3839	4139	220,000	M	50

Add appropriate failure rate level letter (M, P, R or S)

Military Type Designation	Failure Rate Level (%/1,000 Hours)								Cap. (pF)	Cap. Tol.	WV DC
	Standard Lead Length				Optional Longer Lead Length						
	1.0 (M)	0.1 (P)	0.01 (R)	0.001 (S)	1.0 (M)	0.1 (P)	0.01 (R)	0.001 (S)			
Style CKR24, Voltage-temperature limits of ±15% (+15%, -40% for Rated Voltage)											
CKR24BR124K	0240	0540	0840	1140	3240	3540	3840	4140	120,000	K	100
CKR24BR154K	0241	0541	0841	1141	3241	3541	3841	4141	150,000	K	100
CKR24BR154M	0242	0542	0842	1142	3242	3542	3842	4142	150,000	M	100
CKR24BR184K	0243	0543	0843	1143	3243	3543	3843	4143	180,000	K	50
CKR24BR224K	0244	0544	0844	1144	3244	3544	3844	4144	220,000	K	50
CKR24BR224M	0245	0545	0845	1145	3245	3545	3845	4145	220,000	M	50
CKR24BR274K	0246	0546	0846	1146	3246	3546	3846	4146	270,000	K	50
CKR24BR334K	0247	0547	0847	1147	3247	3547	3847	4147	330,000	K	50
CKR24BR334M	0248	0548	0848	1148	3248	3548	3848	4148	330,000	M	50
CKR24BR394K	0249	0549	0849	1149	3249	3549	3849	4149	390,000	K	50
CKR24BR474K	0250	0550	0850	1150	3250	3550	3850	4150	470,000	K	50
CKR24BR474M	0251	0551	0851	1151	3251	3551	3851	4151	470,000	M	50
CKR24BR564K	0252	0552	0852	1152	3252	3552	3852	4152	560,000	K	50
CKR24BR684K	0253	0553	0853	1153	3253	3553	3853	4153	680,000	K	50
CKR24BR684M	0254	0554	0854	1154	3254	3554	3854	4154	680,000	M	50
CKR24BR824K	0255	0555	0855	1155	3255	3555	3855	4155	820,000	K	50
CKR24BR105K	0256	0556	0856	1156	3256	3556	3856	4156	1,000,000	K	50
CKR24BR105M	0257	0557	0857	1157	3257	3557	3857	4157	1,000,000	M	50

Add appropriate failure rate level letter (M, P, R or S)

MARKING

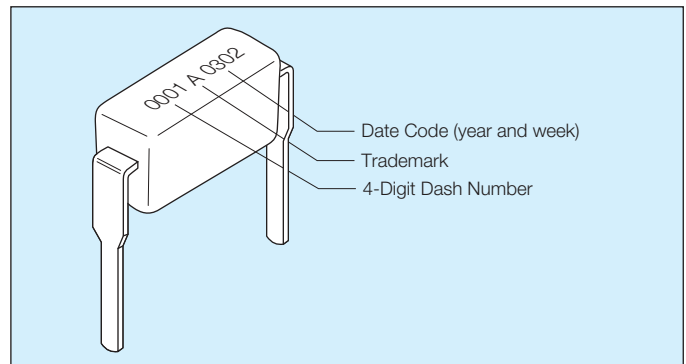

Military Ceramic Leaded Capacitors



MIL-PRF-11015/18, /19 - Radial Leads

HOW TO ORDER

Military Type Designation: Styles CK05, CK06

For values, tolerances, voltages, sizes, configurations and dielectrics not shown, contact AVX facilities directly for information.

CK05

Style

BX

Voltage-Temperature Limits

104

Capacitance Code

K

Capacitance Tolerance

MIL PART NO. CODES

Style: CK = General purpose, ceramic dielectric, fixed capacitors.

05 = Remaining two numbers identify shape and dimension.

Voltage-Temperature Limits:

First letter identifies temperature range.

B = -55°C to +125°C

Second letter identifies voltage-temperature coefficient.

Capacitance Change with Reference to 25°C		
Second Letter	No Voltage	Rated Voltage
X	+15, -15%	+15, -25%

Sig. Fig. Capacitance and Multiplier:

First two digits are the significant figures of capacitance. Third digit indicates the additional number of zeros. For example, order 100,000 pF as 104.

Capacitance Tolerances: K = ±10%, M = ±20%

Packaging: CK05 1000 per bag
CK06 1000 per bag

Radial tape and reel packaging available upon request (2500 pcs./reel).

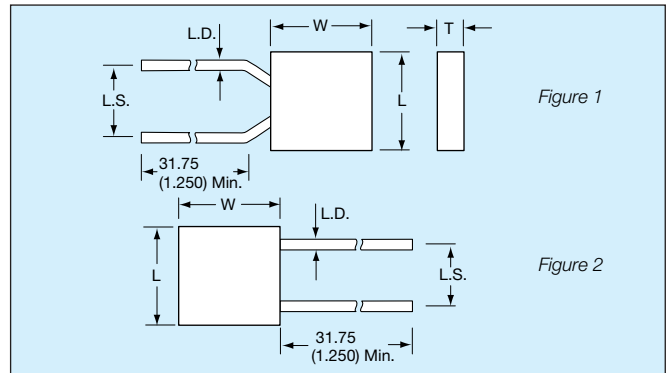

SIZE SPECIFICATIONS millimeters (inches)

Case Size	Per Mil Spec	
	CK05 (Fig. 1)	CK06 (Fig. 2)
MIL-PRF-11015		
Length (L)	4.83±.25 (0.190±0.010)	7.37±.25 (0.290±0.010)
Width (W)	4.83±.25 (0.190±0.010)	7.37±.25 (0.290±0.010)
Thickness (T)	2.29±.25 (0.090±0.010)	2.29±.25 (0.090±0.010)
Lead Spacing (L.S.)	5.08±.38 (0.200±0.015)	5.08±.38 (0.200±0.015)
Lead Diameter (L.D.)	.64±.05 (0.025±0.002)	.64±.05 (0.025±0.002)

Military Ceramic Leaded Capacitors



MIL-PRF-11015/18, /19 - Radial Leads

MILITARY PART NUMBER IDENTIFICATION CK05 AND CK06

Military Type Designation	Capacitance (pF)	Capacitance Tolerance	WVDC
CK05 (BX)			
CK05BX100_	10	K, M	200
CK05BX120K_	12	K	200
CK05BX150	15	K, M	200
CK05BX180K_	18	K	200
CK05BX220_	22	K, M	200
CK05BX270K_	27	K	200
CK05BX330	33	K, M	200
CK05BX390K_	39	K	200
CK05BX470	47	K, M	200
CK05BX560K_	56	K	200
CK05BX680	68	K, M	200
CK05BX820K_	82	K	200
CK05BX101_	100	K, M	200
CK05BX121K_	120	K	200
CK05BX151_	150	K, M	200
CK05BX181K_	180	K	200
CK05BX221_	220	K, M	200
CK05BX271K_	270	K	200
CK05BX331	330	K, M	200
CK05BX391K_	390	K	200
CK05BX471	470	K, M	200
CK05BX561K_	560	K	200
CK05BX681	680	K, M	200
CK05BX821K_	820	K	200
CK05BX102_	1,000	K, M	200
CK05BX122_	1,200	K	100
CK05BX152_	1,500	K, M	100
CK05BX182K_	1,800	K	100
CK05BX222_	2,200	K, M	100
CK05BX272K_	2,700	K	100
CK05BX332	3,300	K, M	100
CK05BX392K_	3,900	K	100
CK05BX472	4,700	K, M	100
CK05BX562K_	5,600	K	100
CK05BX682_	6,800	K, M	100
CK05BX822K_	8,200	K	100
CK05BX103	10,000	K, M	100
CK05BX123K_	12,000	K	50
CK05BX153	15,000	K, M	50
CK05BX183K_	18,000	K	50
CK05BX223_	22,000	K, M	50
CK05BX273K_	27,000	K	50
CK05BX333	33,000	K, M	50
CK05BX393K_	39,000	K	50
CK05BX473_	47,000	K, M	50
CK05BX563K_	56,000	K	50
CK05BX683_	68,000	K, M	50
CK05BX823K_	82,000	K	50
CK05BX104_	100,000	K, M	50

Add Capacitance Tolerance Letter K = ±10% or M = ±20%

Military Type Designation	Capacitance (pF)	Capacitance Tolerance	WVDC
CK06 (BX)			
CK06BX122K_	1,200	K	200
CK06BX152	1,500	K, M	200
CK06BX182K_	1,800	K	200
CK06BX222	2,200	K, M	200
CK06BX272K_	2,700	K	200
CK06BX332	3,300	K, M	200
CK06BX392K_	3,900	K	200
CK06BX472	4,700	K, M	200
CK06BX562K_	5,600	K	200
CK06BX682_	6,800	K, M	200
CK06BX822K_	8,200	K	200
CK06BX103	10,000	K, M	200
CK06BX123K_	12,000	K	100
CK06BX153	15,000	K, M	100
CK06BX183K_	18,000	K	100
CK06BX223	22,000	K, M	100
CK06BX273K_	27,000	K	100
CK06BX333	33,000	K, M	100
CK06BX393K_	39,000	K	100
CK06BX473_	47,000	K, M	100
CK06BX563K_	56,000	K	100
CK06BX683	68,000	K, M	100
CK06BX823K_	82,000	K	100
CK06BX104	100,000	K, M	100
CK06BX124K_	120,000	K	50
CK06BX154	150,000	K, M	50
CK06BX184K_	180,000	K	50
CK06BX224	220,000	K, M	50
CK06BX274K_	270,000	K	50
CK06BX334	330,000	K, M	50
CK06BX394K_	390,000	K	50
CK06BX474	470,000	K, M	50
CK06BX564K_	560,000	K	50
CK06BX684	680,000	K, M	50
CK06BX824K_	820,000	K	50
CK06BX105	1.0 mfd	K, M	50

Add Capacitance Tolerance Letter K = ±10% or M = ±20%

MARKING

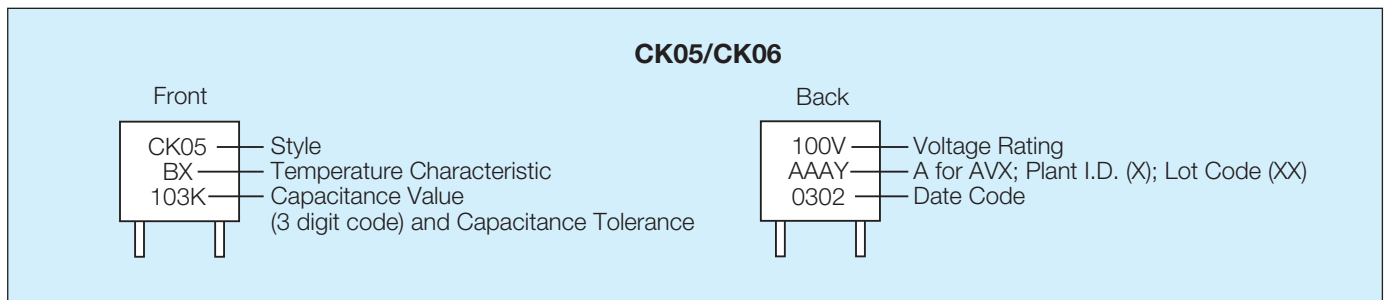

Military Ceramic Leaded Capacitors



MIL-PRF-11015/20, /25 - Axial Leads

HOW TO ORDER

Military Type Designation: Styles CK12, CK13, CK14, CK15, CK16

CK12

Style

BX

Voltage-Temperature Limits

103

Capacitance Code

K

Capacitance Tolerance

MIL PART NO. CODES

Style: CK = general purpose, ceramic dielectric, fixed capacitors.

12 = Remaining two numbers identify shape and dimension.

Voltage-Temperature Limits:

First letter identifies temperature range.

B = -55°C to +125°C

Second letter identifies voltage-temperature coefficient.

Capacitance Change with Reference to 25°C		
Second Letter	No Voltage	Rated Voltage
R	+15, -15%	+15, -40%
X	+15, -15%	+15, -25%

Sig. Fig. Capacitance and Multiplier:

First two digits are the significant figures of capacitance. Third digit indicates the additional number of zeros. For example, order 10,000 pF as 103.

Capacitance Tolerances: K = ±10%, M = ±20%

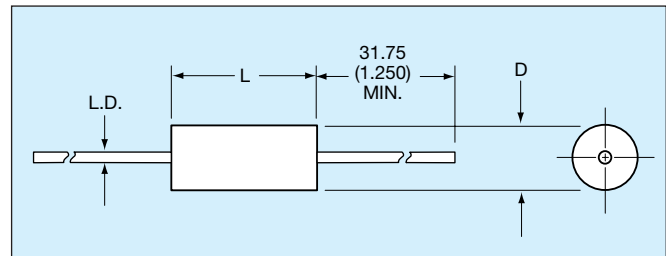

SIZE SPECIFICATIONS millimeters (inches)

Case Size	Per Mil Spec				
	CK12	CK13	CK14	CK15	CK16
MIL-PRF-11015					
Length (L)	4.07±.25 (0.160±0.010)	6.35±.25 (0.250±0.010)	9.91±.25 (0.390±0.010)	12.7±.51 (0.500±0.020)	17.53±.51 (0.690±0.020)
Diameter (D)	2.29±.25 (0.090±0.010)	2.29±.25 (0.090±0.010)	3.56±.25 (0.140±0.010)	6.35±.38 (0.250±0.015)	8.89±.51 (0.350±0.015)
Lead Diameter (L.D.)	.48±.05 (0.019±0.002)	.48±.05 (0.019±0.002)	.63±.05 (0.025±0.002)	.63±.05 (0.025±0.002)	.63±.05 (0.025±0.002)

PACKAGING REQUIREMENTS

Packaging:

Bulk

CK12, 13 & 14 100 pcs per bag

CK15 & 16 50 pcs per bag

Tape & Reel

CK12, 13 5000 pcs per reel

CK14 3000 pcs per reel

CK15 950 pcs per reel

CK16 650 pcs per reel

Military Ceramic Leaded Capacitors



MIL-PRF-11015/20, /25 - Axial Leads

MILITARY PART NUMBER IDENTIFICATION CK12 THRU CK16

Military Type Designation	Capacitance (pF)	Capacitance Tolerance	WVDC
CK12 (BX)			
CK12BX100_	10	K, M	100
CK12BX120K	12	K	100
CK12BX150_	15	K, M	100
CK12BX180K	18	K	100
CK12BX220_	22	K, M	100
CK12BX270K	27	K	100
CK12BX330_	33	K, M	100
CK12BX390K	39	K	100
CK12BX470_	47	K, M	100
CK12BX560K	56	K	100
CK12BX680_	68	K, M	100
CK12BX820K	82	K	100
CK12BX101_	100	K, M	100
CK12BX121K	120	K	100
CK12BX151_	150	K, M	100
CK12BX181K	180	K	100
CK12BX221_	220	K, M	100
CK12BX271K	270	K	100
CK12BX331_	330	K, M	100
CK12BX391K	390	K	100
CK12BX471_	470	K, M	100
CK12BX561K	560	K	100
CK12BX681_	680	K, M	100
CK12BX821K	820	K	100
CK12BX102_	1,000	K, M	100
CK12BX122K	1,200	K	100
CK12BX152_	1,500	K, M	100
CK12BX182K	1,800	K	100
CK12BX222_	2,200	K, M	100
CK12BX272K	2,700	K	100
CK12BX332_	3,300	K, M	100
CK12BX392K	3,900	K	100
CK12BX472_	4,700	K, M	100
CK12BX562K	5,600	K	50
CK12BX682_	6,800	K, M	50
CK12BX822K	8,200	K	50
CK12BX103_	10,000	K, M	50
CK13 (BX)			
CK13BX562K	5,600	K	100
CK13BX682_	6,800	K, M	100
CK13BX822K	8,200	K	100
CK13BX103_	10,000	K, M	100
CK13BX123K	12,000	K	50
CK13BX153_	15,000	K, M	50
CK13BX183K	18,000	K	50
CK13BX223_	22,000	K, M	50
CK13 (BR)			
CK13BR273K	27,000	K	50
CK13BR333_	33,000	K, M	50
CK13BR393K	39,000	K	50
CK13BR473_	47,000	K, M	50

Add Capacitance Tolerance Letter K = ±10% or M = ±20%

Military Type Designation	Capacitance (pF)	Capacitance Tolerance	WVDC
CK14 (BX)			
CK14BX123K	12,000	K	100
CK14BX153_	15,000	K, M	100
CK14BX183K	18,000	K	100
CK14BX223_	22,000	K, M	100
CK14BX273K	27,000	K	100
CK14BX333_	33,000	K, M	100
CK14BX393K	39,000	K	100
CK14BX473_	47,000	K, M	100
CK14 (BR)			
CK14BR563K	56,000	K	100
CK14BR683_	68,000	K, M	100
CK14BR823K	82,000	K	100
CK14BR104_	100,000	K, M	100
CK14BR124K	120,000	K	50
CK14BR154_	150,000	K, M	50
CK14BR184K	180,000	K	50
CK14BR224_	220,000	K, M	50
CK14BR274K	270,000	K	50
CK15 (BX)			
CK15BX104K	100,000	K, M	100
CK15 (BR)			
CK15BR124K	120,000	K	100
CK15BR154_	150,000	K, M	100
CK15BR184K	180,000	K	100
CK15BR224_	220,000	K, M	100
CK15BR274K	270,000	K	100
CK15BR334_	330,000	K, M	100
CK15BR474K	470,000	K, M	50
CK15BR105_	1,000,000	K, M	50
CK16 (BR)			
CK16BR474K	470,000	K, M	100
CK16BR105_	1,000,000	K, M	100
CK16BR225_	2,200,000	K, M	50
CK16BR335_	3,300,000	K, M	50

Add Capacitance Tolerance Letter K = ±10% or M = ±20%

MARKING

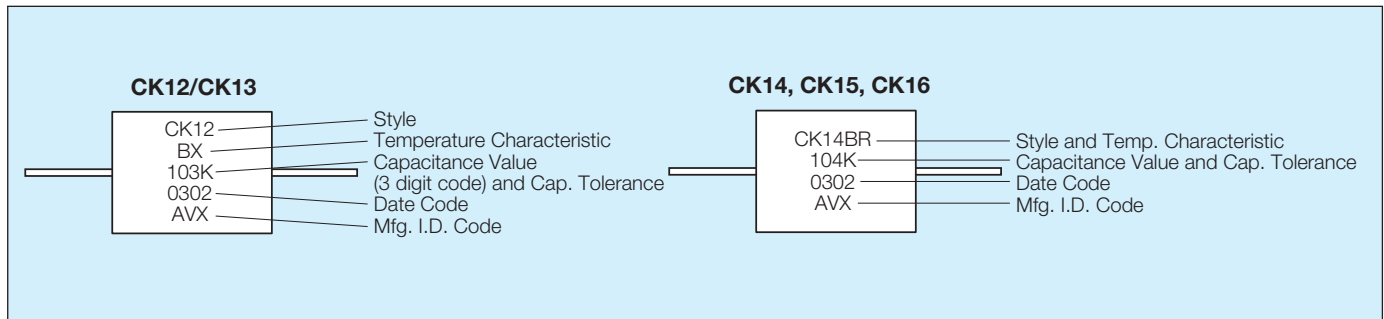

Military Ceramic Leaded Capacitors



MIL-PRF-20/35, /36 - Radial Leads

HOW TO ORDER

Military Type Designation:

Established Reliability = CCR05, CCR06, CCR07, CCR08, CCR09

Non-Established Reliability = CC05, CC06, CC07, CC08, CC09

CCR06

Style

CG

Temperature Characteristic

183

Capacitance Code

J

Capacitance Tolerance

R

Military Failure Rate

(V)

Stand-off Option

MIL PART NO. CODES

Style: CC = Identifies temperature compensating, ceramic dielectric, fixed capacitors.

R = Identifies Established Reliability parts.

06 = Numbers identify shape and dimension.

Temperature Characteristic:

Permissible capacitance change from capacitance at +25°C in ppm/°C					
Temp.	Characteristic				
	CX	CK	CJ	CH	CG
+125°C	1/	±250 ppm/°C	±120 ppm/°C	±60 ppm/°C	±30 ppm/°C
-55°C 2/	1/	+246.25 -326.25	+116.25 -166.25	+55.00 -91.25	+27.50 -53.75

1/ Not practically measurable.

2/ The ppm/°C values for -55°C were calculated by dividing ppm by negative 80°C.

Capacitance Code:

First two digits are the significant figures of capacitance. Third digit indicates the additional number of zeros. For example, order 18,000 pF as 183. (For values below 10 pF, use "R" in place of decimal point, e.g., 1R4 = 1.4pF).

Capacitance Tolerance:

C = ±0.25 pF, D = ±0.5 pF, F = ±1%, G = ±2%,

J = ±5%, K = ±10%

Military Failure Rate:

M = 1% per 1000 hours, P = 0.1% per 1000 hours,

R = 0.01% per 1000 hours, S = 0.001% per 1000 hours.

PACKAGING REQUIREMENTS

Packaging: CCR0X: 100 pcs/bag; CC0X: 1000 pcs/bag

MILITARY PART NUMBER IDENTIFICATION

Military Type Designation	Capacitance (pF)	Capacitance Tolerance	WVDC
CC05-CCR05, CC09-CCR09			
CCR05CX1R0_	1.0	C	200
CCR05CX1R1_	1.1	C	200
CCR05CX1R2_	1.2	C	200
CCR05CX1R3_	1.3	C	200
CCR05CX1R5_	1.5	C	200
CCR05CX1R6_	1.6	C	200
CCR05CX1R8_	1.8	C	200
CCR05CX2R0_	2.0	C	200
CCR05CK2R2_	2.2	C	200
CCR05CK2R4_	2.4	C	200
CCR05CK2R7_	2.7	C, D	200
CCR05CK3R0_	3.0	C, D	200
CCR05CK3R3_	3.3	C, D	200
CCR05CK3R6_	3.6	C, D	200
CCR05CK3R9_	3.9	C, D	200

— Add appropriate failure rate level (M, P, R, or S), add V for Stand-off
— Add appropriate cap. tolerance letter

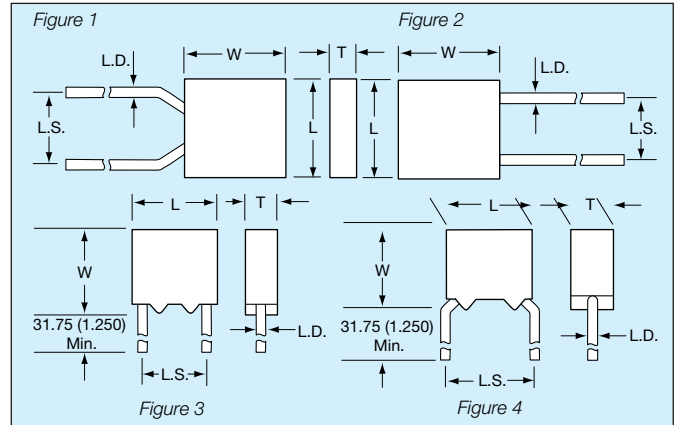

To order stand-off option, place "V" at the end of the part number. For example: CCR05CG332FSV.

SIZE SPECIFICATIONS millimeters (inches)

Per Mil Spec	Case Size				
	Length (L)	Width (W)	Thickness (T)	Lead Spacing (L.S.)	Lead Diameter (L.D.)
MIL-PRF-20 CCR05/CC05 Figures 1, 4	4.83±.25 (0.190±0.010)	4.83±.25 (0.190±0.010)	2.29±.25 (0.090±0.010)	5.08±.38 (0.200±0.015)	.64±.05 (0.025±0.002)
CCR06/CC06 Figures 2, 3	7.37±.25 (0.290±0.010)	7.37±.25 (0.290±0.010)	2.29±.25 (0.090±0.010)	5.08±.38 (0.200±0.015)	.64±.05 (0.025±0.002)
CCR07/CC07 Figure 2	12.19±.51 (0.480±0.020)	12.19±.51 (0.480±0.020)	3.56±.25 (0.140±0.010)	10.16±.51 (0.400±0.020)	.64±.05 (0.025±0.002)
CCR08/CC08 Figure 2	12.19±.51 (0.480±0.020)	12.19±.51 (0.480±0.020)	6.1±.25 (0.240±0.010)	10.16±.51 (0.400±0.020)	.64±.05 (0.025±0.002)
CCR09/CC09 Figure 2	4.83±.25 (0.190±0.010)	4.83±.25 (0.190±0.010)	2.29±.25 (0.090±0.010)	2.54±.38 (0.100±0.015)	.64±.05 (0.025±0.002)

Military Type Designation	Capacitance (pF)	Capacitance Tolerance	WVDC
CC05-CCR05, CC09-CCR09			
CCR05CJ4R3_	4.3	C, D	200
CCR05CJ4R7_	4.7	C, D	200
CCR05CJ5R1_	5.1	C, D	200
CCR05CJ5R6_	5.6	C, D	200
CCR05CJ6R2_	6.2	C, D	200
CCR05CJ6R8_	6.8	C, D	200
CCR05CJ7R5_	7.5	C, D	200
CCR05CH8R2_	8.2	C, D	200
CCR05CH9R1_	9.1	C, D	200
CCR05CH100_	10	G, J	200
CCR05CH110_	11	G, J	200
CCR05CH120_	12	G, J	200
CCR05CH130_	13	G, J	200
CCR05CH150_	15	G, J	200
CCR05CH160_	16	G, J	200

— Add appropriate failure rate level (M, P, R, or S), add V for Stand-off
— Add appropriate cap. tolerance letter



Military Ceramic Leaded Capacitors



MIL-PRF-20/35, /36 - Radial Leads

MILITARY PART NUMBER IDENTIFICATION

Military Type Designation	Capacitance (pF)	Capacitance Tolerance	WVDC
CC05-CCR05, CC09-CCR09			
CCR05CH180	18	G, J	200
CCR05CG200	20	G, J	200
CCR05CG220	22	G, J	200
CCR05CG240	24	G, J	200
CCR05CG270	27	F, G, J	200
CCR05CG300	30	F, G, J	200
CCR05CG330	33	F, G, J	200
CCR05CG360	36	F, G, J	200
CCR05CG390	39	F, G, J	200
CCR05CG430	43	F, G, J	200
CCR05CG470	47	F, G, J	200
CCR05CG510	51	F, G, J	200
CCR05CG560	56	F, G, J	200
CCR05CG620	62	F, G, J	200
CCR05CG680	68	F, G, J	200
CCR05CG750	75	F, G, J	200
CCR05CG820	82	F, G, J	200
CCR05CG910	91	F, G, J	200
CCR05CG101	100	F, G, J	200
CCR05CG111	110	F, G, J	200
CCR05CG121	120	F, G, J	200
CCR05CG131	130	F, G, J	200
CCR05CG151	150	F, G, J	200
CCR05CG161	160	F, G, J	200
CCR05CG181	180	F, G, J	200
CCR05CG201	200	F, G, J	200
CCR05CG221	220	F, G, J	200
CCR05CG241	240	F, G, J	200
CCR05CG271	270	F, G, J	200
CCR05CG301	300	F, G, J	200
CCR05CG331	330	F, G, J	200
CCR05CG361	360	F, G, J	100
CCR05CG391	390	F, G, J	100
CCR05CG431	430	F, G, J	100
CCR05CG471	470	F, G, J	100
CCR05CG511	510	F, G, J	100
CCR05CG561	560	F, G, J	100
CCR05CG621	620	F, G, J	100
CCR05CG681	680	F, G, J	100
CCR05CG751	750	F, G, J	100
CCR05CG821	820	F, G, J	100
CCR05CG911	910	F, G, J	100
CCR05CG102	1,000	F, G, J	100
CCR05CG112	1,100	F, G, J	100
CCR05CG122	1,200	F, G, J	100
CCR05CG132	1,300	F, G, J	100
CCR05CG152	1,500	F, G, J	100
CCR05CG162	1,600	F, G, J	100
CCR05CG182	1,800	F, G, J	100
CCR05CG202	2,000	F, G, J	50
CCR05CG222	2,200	F, G, J	50
CCR05CG242	2,400	F, G, J	50
CCR05CG272	2,700	F, G, J	50
CCR05CG302	3,000	F, G, J	50
CCR05CG332	3,300	F, G, J	50
CC06, CCR06			
CCR06CG361	360	F, G, J	200
CCR06CG391	390	F, G, J	200
CCR06CG431	430	F, G, J	200
CCR06CG471	470	F, G, J	200
CCR06CG511	510	F, G, J	200
CCR06CG561	560	F, G, J	200
CCR06CG621	620	F, G, J	200
CCR06CG681	680	F, G, J	200
CCR06CG751	750	F, G, J	200
CCR06CG821	820	F, G, J	200

— Add appropriate failure rate level (M, P, R or S)
 — Add appropriate cap. tolerance letter

Military Type Designation	Capacitance (pF)	Capacitance Tolerance	WVDC
CC06, CCR06 (cont)			
CCR06CG911	910	F, G, J	200
CCR06CG102	1,000	F, G, J	200
CCR06CG112	1,100	F, G, J	200
CCR06CG122	1,200	F, G, J	200
CCR06CG132	1,300	F, G, J	200
CCR06CG152	1,500	F, G, J	200
CCR06CG162	1,600	F, G, J	200
CCR06CG182	1,800	F, G, J	200
CCR06CG202	2,000	F, G, J	100
CCR06CG222	2,200	F, G, J	100
CCR06CG242	2,400	F, G, J	100
CCR06CG272	2,700	F, G, J	100
CCR06CG302	3,000	F, G, J	100
CCR06CG332	3,300	F, G, J	100
CCR06CG362	3,600	F, G, J	100
CCR06CG392	3,900	F, G, J	100
CCR06CG432	4,300	F, G, J	100
CCR06CG472	4,700	F, G, J	100
CCR06CG512	5,100	F, G, J, K	50
CCR06CG562	5,600	F, G, J, K	50
CCR06CG622	6,200	F, G, J, K	50
CCR06CG682	6,800	F, G, J, K	50
CCR06CG752	7,500	F, G, J, K	50
CCR06CG822	8,200	F, G, J, K	50
CCR06CG912	9,100	F, G, J, K	50
CCR06CG103	10,000	F, G, J, K	50
CCR06CG123	12,000	F, G, J, K	50
CCR06CG153	15,000	F, G, J, K	50
CCR06CG183	18,000	F, G, J, K	50
CC07, CCR07			
CCR07CG222	2,200	F, G, J, K	200
CCR07CG272	2,700	F, G, J, K	200
CCR07CG332	3,300	F, G, J, K	200
CCR07CG392	3,900	F, G, J, K	200
CCR07CG472	4,700	F, G, J, K	200
CCR07CG562	5,600	F, G, J, K	100
CCR07CG682	6,800	F, G, J, K	100
CCR07CG822	8,200	F, G, J, K	100
CCR07CG103	10,000	F, G, J, K	100
CCR07CG123	12,000	F, G, J, K	100
CCR07CG153	15,000	F, G, J, K	50
CCR07CG183	18,000	F, G, J, K	50
CCR07CG223	22,000	F, G, J, K	50
CCR07CG273	27,000	F, G, J, K	50
CCR07CG333	33,000	F, G, J, K	50
CCR07CG393	39,000	F, G, J, K	50
CCR07CG473	47,000	F, G, J, K	50
CCR07CG563	56,000	F, G, J, K	50
CCR07CG683	68,000	F, G, J, K	50
CCR07CG823	82,000	F, G, J, K	50
CCR07CG104	100,000	F, G, J, K	50
CC08, CCR08			
CCR08CG392	3,900	G, J, K	200
CCR08CG472	4,700	G, J, K	200
CCR08CG153	15,000	G, J, K	100
CCR08CG183	18,000	G, J, K	100
CCR08CG563	56,000	G, J, K	50
CCR08CG683	68,000	G, J, K	50

— Add appropriate failure rate level (M, P, R or S)
 — Add appropriate cap. tolerance letter

Note: For marking information, see page 23.



Military Ceramic Leaded Capacitors



MIL-PRF-20/28, /29, /30, /31 - Axial Leads

HOW TO ORDER

Military Type Designation:

Established Reliability = CCR75, CCR76, CCR77, CCR78, CCR79

Non-Established Reliability = CC75, CC76, CC77, CC78, CC79

CCR76

Style

CG

Temperature Characteristic

102

Capacitance Code

J

Capacitance Tolerance

R

Military Failure Rate

MIL PART NO. CODES

Style: CC = Identifies temperature compensating, ceramic dielectric, fixed capacitors.

R = Identifies Established Reliability parts.

76 = Numbers identify shape and dimension.

Temperature Characteristic:

Permissible capacitance change from capacitance at +25°C in ppm/°C					
Temp.	Characteristic				
	CX	CK	CJ	CH	CG
+125°C	1/	±250 ppm/°C	±120 ppm/°C	±60 ppm/°C	±30 ppm/°C
-55°C 2/	1/	+246.25 -326.25	+116.25 -166.25	+55.00 -91.25	+27.50 -53.75

1/ Not practically measurable.

Capacitance Code:

First two digits are the significant figures of capacitance. Third digit indicates the additional number of zeros. For example, order 1,000 pF as 102. (For values below 10 pF, use "R" in place of decimal point, e.g., 1R8 - 1.8pF).

Capacitance Tolerance:

C = ±0.25 pF, D = ±0.5 pF, F = ±1%,

G = ±2%, J = ±5%, K = ±10%

Military Failure Rate:

M = 1% per 1000 hours, P = 0.1% per 1000 hours,

R = 0.01% per 1000 hours, S = 0.001% per 1000 hours.

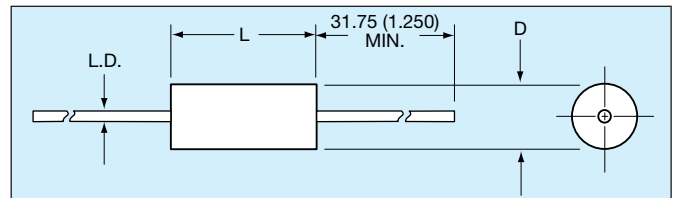

SIZE SPECIFICATIONS millimeters (inches)

Per Mil Spec	Case Size		
	Length (L)	Diameter (D)	Lead Diameter (L.D.)
MIL-PRF-20			
CCR75 CC75	4.07±.25 (0.160±0.010)	2.29±.25 (0.090±0.010)	.48±.05 (0.019±0.002)
CCR76 CC76	6.35±.25 (0.250±0.010)	2.29±.25 (0.090±0.010)	.48±.05 (0.019±0.002)
CCR77 CC77	9.91±.25 (0.390±0.010)	3.56±.25 (0.140±0.010)	.63±.051 (0.025±0.002)
CCR78 CC78	12.7±.51 (0.500±0.020)	6.35±.38 (0.250±0.015)	.63±.05 (0.025±0.002)
CCR79 CC79	17.53±.51 (0.690±0.020)	8.89±.51 (0.350±0.015)	.63±.05 (0.025±0.002)

PACKAGING REQUIREMENTS

Packaging:

Bulk

CCR75/CC75, CCR76/CC76, CCR77/CC77, 100 pcs/bag
CCR78/CC78, CCR79/CC79 50 pcs/bag

Tape & Reel

CCR75/CC75, CCR76/CC76
CCR77/CC77
CCR78/CC78
CCR79/CC79

5000 pcs/reel
3000 pcs/reel
950 pcs/reel
650 pcs/reel

Military Ceramic Leaded Capacitors



MIL-PRF-20/28, /29, /30, /31 - Axial Leads

MILITARY PART NUMBER IDENTIFICATION CC75 THRU CC79 AND CCR75 THRU CCR79

Military Type Designation	Cap. (pF)	Cap. Tol.	WVDC
CC75-CCR75			
CCR75CX1R0_	1.0	C	200
CCR75CX1R1_	1.1	C	200
CCR75CX1R2_	1.2	C	200
CCR75CX1R3_	1.3	C	200
CCR75CX1R5_	1.5	C	200
CCR75CX1R6_	1.6	C	200
CCR75CX1R8_	1.8	C	200
CCR75CX2R0_	2.0	C	200
CCR75CK2R2_	2.2	C	200
CCR75CK2R4_	2.4	C	200
CCR75CK2R7_	2.7	C, D	200
CCR75CK3R0_	3.0	C, D	200
CCR75CK3R3_	3.3	C, D	200
CCR75CK3R6_	3.6	C, D	200
CCR75CK3R9_	3.9	C, D	200
CCR75CJ4R3_	4.3	C, D	200
CCR75CJ4R7_	4.7	C, D	200
CCR75CJ5R1_	5.1	C, D	200
CCR75CJ5R6_	5.6	C, D	200
CCR75CJ6R2_	6.2	C, D	200
CCR75CJ6R8_	6.8	C, D	200
CCR75CJ7R5_	7.5	C, D	200
CCR75CH8R2_	8.2	C, D	200
CCR75CH9R1_	9.1	C, D	200
CCR75CH100_	10	G, J	200
CCR75CH110_	11	G, J	200
CCR75CH120_	12	G, J	200
CCR75CH130_	13	G, J	200
CCR75CH150_	15	G, J	200
CCR75CH160_	16	G, J	200
CCR75CH180_	18	G, J	200
CCR75CG200_	20	F, G, J	200
CCR75CG220_	22	F, G, J	200
CCR75CG240_	24	F, G, J	200
CCR75CG270_	27	F, G, J	200
CCR75CG300_	30	F, G, J	200
CCR75CG330_	33	F, G, J	200
CCR75CG360_	36	F, G, J	200
CCR75CG390_	39	F, G, J	200
CCR75CG430_	43	F, G, J	200
CCR75CG470_	47	F, G, J	200
CCR75CG510_	51	F, G, J	200
CCR75CG560_	56	F, G, J	200
CCR75CG620_	62	F, G, J	200
CCR75CG680_	68	F, G, J	200
CCR75CG750_	75	F, G, J	200
CCR75CG820_	82	F, G, J	100
CCR75CG910_	91	F, G, J	100
CCR75CG101_	100	F, G, J	100
CCR75CG111_	110	F, G, J	100
CCR75CG121_	120	F, G, J	100
CCR75CG131_	130	F, G, J	100
CCR75CG151_	150	F, G, J	100
CCR75CG161_	160	F, G, J	100
CCR75CG181_	180	F, G, J	100
CCR75CG201_	200	F, G, J	100
CCR75CG221_	220	F, G, J	100
CCR75CG241_	240	F, G, J	100
CCR75CG271_	270	F, G, J	50
CCR75CG301_	300	F, G, J	50
CCR75CG331_	330	F, G, J	50
CCR75CG361_	360	F, G, J	50
CCR75CG391_	390	F, G, J	50
CCR75CG431_	430	F, G, J	50
CCR75CG471_	470	F, G, J	50
CCR75CG511_	510	F, G, J	50
CCR75CG561_	560	F, G, J	50
CCR75CG621_	620	F, G, J	50
CCR75CG681_	680	F, G, J	50

— Add appropriate failure rate level (M, P, R or S)
— Add appropriate cap. tolerance letter

Military Type Designation	Cap. (pF)	Cap. Tol.	WVDC
CC76, CCR76			
CCR76CG820_	82	F, G, J	200
CCR76CG910_	91	F, G, J	200
CCR76CG101_	100	F, G, J	200
CCR76CG111_	110	F, G, J	200
CCR76CG121_	120	F, G, J	200
CCR76CG131_	130	F, G, J	200
CCR76CG271_	270	F, G, J	100
CCR76CG301_	300	F, G, J	100
CCR76CG331_	330	F, G, J	100
CCR76CG361_	360	F, G, J	100
CCR76CG391_	390	F, G, J	100
CCR76CG431_	430	F, G, J	100
CCR76CG471_	470	F, G, J	100
CCR76CG511_	510	F, G, J	100
CCR76CG561_	560	F, G, J	100
CCR76CG621_	620	F, G, J	100
CCR76CG681_	680	F, G, J	100
CCR76CG751_	750	F, G, J	50
CCR76CG821_	820	F, G, J	50
CCR76CG911_	910	F, G, J	50
CCR76CG102_	1,000	F, G, J	50
CC77, CCR77			
CCR77CG151_	150	F, G, J	200
CCR77CG161_	160	F, G, J	200
CCR77CG181_	180	F, G, J	200
CCR77CG201_	200	F, G, J	200
CCR77CG221_	220	F, G, J	200
CCR77CG241_	240	F, G, J	200
CCR77CG271_	270	F, G, J	200
CCR77CG301_	300	F, G, J	200
CCR77CG331_	330	F, G, J	200
CCR77CG361_	360	F, G, J	200
CCR77CG391_	390	F, G, J	200
CCR77CG431_	430	F, G, J	200
CCR77CG471_	470	F, G, J	200
CCR77CG511_	510	F, G, J	200
CCR77CG561_	560	F, G, J	200
CCR77CG621_	620	F, G, J	200
CCR77CG681_	680	F, G, J	200
CCR77CG751_	750	F, G, J	100
CCR77CG821_	820	F, G, J	100
CCR77CG911_	910	F, G, J	100
CCR77CG102_	1,000	F, G, J	100
CCR77CG112_	1,100	F, G, J	100
CCR77CG122_	1,200	F, G, J	100
CCR77CG132_	1,300	F, G, J	100
CCR77CG152_	1,500	F, G, J	100
CCR77CG162_	1,600	F, G, J	100
CCR77CG182_	1,800	F, G, J	100
CCR77CG202_	2,000	F, G, J	100
CCR77CG222_	2,200	F, G, J	100
CCR77CG242_	2,400	F, G, J	50
CCR77CG272_	2,700	F, G, J	50
CCR77CG302_	3,000	F, G, J	50
CCR77CG332_	3,300	F, G, J	50
CCR77CG362_	3,600	F, G, J	50
CCR77CG392_	3,900	F, G, J	50
CCR77CG432_	4,300	F, G, J	50
CCR77CG472_	4,700	F, G, J	50
CCR77CG512_	5,100	F, G, J, K	50
CCR77CG562_	5,600	F, G, J, K	50

— Add appropriate failure rate level (M, P, R or S)
— Add appropriate cap. tolerance letter

Military Type Designation	Cap. (pF)	Cap. Tol.	WVDC
CC78, CCR78			
CCR78CG821_	820	F, G, J, K	200
CCR78CG102_	1,000	F, G, J, K	200
CCR78CG122_	1,200	F, G, J, K	200
CCR78CG152_	1,500	F, G, J, K	200
CCR78CG182_	1,800	F, G, J, K	200
CCR78CG222_	2,200	F, G, J, K	200
CCR78CG272_	2,700	F, G, J, K	200
CCR78CG332_	3,300	F, G, J, K	200
CCR78CG392_	3,900	F, G, J, K	100
CCR78CG472_	4,700	F, G, J, K	100
CCR78CG562_	5,600	F, G, J, K	100
CCR78CG682_	6,800	F, G, J, K	100
CCR78CG822_	8,200	F, G, J, K	100
CCR78CG103_	10,000	F, G, J, K	100
CCR78CG123_	12,000	F, G, J, K	100
CCR78CG153_	15,000	F, G, J, K	50
CCR78CG183_	18,000	F, G, J, K	50
CCR78CG223_	22,000	F, G, J, K	50
CCR78CG273_	27,000	F, G, J, K	50
CC79, CCR79			
CCR79CG392_	3,900	F, G, J, K	200
CCR79CG472_	4,700	F, G, J, K	200
CCR79CG562_	5,600	F, G, J, K	200
CCR79CG682_	6,800	F, G, J, K	200
CCR79CG822_	8,200	F, G, J, K	200
CCR79CG103_	10,000	F, G, J, K	200
CCR79CG153_	15,000	F, G, J, K	100
CCR79CG183_	18,000	F, G, J, K	100
CCR79CG223_	22,000	F, G, J, K	100
CCR79CG273_	27,000	F, G, J, K	100
CCR79CG333_	33,000	F, G, J, K	100
CCR79CG393_	39,000	F, G, J, K	100
CCR79CG473_	47,000	F, G, J, K	50
CCR79CG563_	56,000	F, G, J, K	50
CCR79CG683_	68,000	F, G, J, K	50
CCR79CG823_	82,000	F, G, J, K	50

— Add appropriate failure rate level (M, P, R or S)
— Add appropriate cap. tolerance letter

Note: For marking information, see page 23.

Note: Complete type designation will include the appropriate capacitance tolerance in the 11th digit. For CC styles, delete 3rd and 12th digits.



Military Ceramic Leaded Capacitors



MIL-PRF-20

MARKING

Radials

CC05 & CC09

CC05
CH
100G
FRONT

0302
A0
4222
BACK

Date Code
A=Lot Letter
0=1st Digit of AVX FSCM #
4222=Last four digits of AVX FSCM #

CCR05 & CCR09

CCR0
5CH1
00GM
FRONT

0302
AJ0
4222
BACK

Date Code
A=Lot Letter
J="J" or "JAN" Brand
0=1st Digit of AVX FSCM #
4222=Last four digits of AVX FSCM #

CC06

CC06
CG
102F
FRONT

0302A
200V
04222
BACK

Date Code & Lot Letter
200V=Rated Voltage
04222=AVX FSCM #

CCR06

CCR06
CG102
FM
FRONT

0302A
J200V
04222
BACK

Date Code & Lot Letter
J="J" or "JAN" Brand
200V=Rated Voltage
04222=AVX FSCM #

CC07

CG
103
G3
AAVX

Characteristic
Capacitance Value
Cap. Tolerance & Year Code (3 for 2003)

CCR07

JCG
103
GM3
AAVX

"J" Brand (J) and Characteristic (CG)
Capacitance Value
Cap. Tolerance (G) FR Level (M), & Year Code (3 for 2003)
Lot Code (A); and Trademark (AVX)

CC08

CC08CG
392K
AVX
96095
200V 0302A

Trademark or Manufacturer's Name
Source Code (FSCM)
Voltage, Date Code and Lot Symbol

CCR08

CCR08CG
392KM
JAN AVX
96095
200V 0302A

"JAN" Brand & Trademark or Manufacturer's Name
Source Code (FSCM)
Voltage, Date Code and Lot Symbol

Axials

CC75, CC76

CG
101
G03
20AAA

Characteristic
Capacitance Value
Cap. Tolerance & 2 digit Year Code
2 digit Week, 2 digit Lot Code, A for AVX

CCR75, CCR76

JCG
101
GM03
20AAA

"J" Brand (J) and Characteristic (CG)
Capacitance Value
Cap. Tolerance (G) FR Level (M), & 2 digit Year Code
2 digit Week, A for AVX

CC77

CC77C
G151F
04222
0302AA

Type Designation
FSCM
4 digit Date Code, 2 digit Lot Code

CCR77

CCR77C
G151FM
J04222
0302AA

Type Designation
"J" Brand and FSCM
4 digit Date Code, 2 digit Lot Code

CC78, CC79

CC78CG
821K
AVX
04222
200V
0302AA

Type Designation
Trademark or Manufacturer's Name
Source Code (FSCM)
Voltage
4 digit Date Code

CCR78, CCR79

CCR78
CG
821KM
JAN A
04222
200V
0302AA

Type Designation
TC
Capacitance Tolerance, Failure Rate
"JAN" Brand, A for AVX
FSCM
Voltage
4 digit Date Code, 2 digit Lot Code

Military Ceramic Leaded Capacitors



MIL-PRF-123/01, /02, /04, /05, /06, /07, /08, /16, /17, /18

HOW TO ORDER

Military Type Designation: Capacitors, Fixed, Ceramic Dielectric, (Temperature Stable and General Purpose), High Reliability

M123

Mil-Spec Number

A

Modification Spec.

01

Slash Sheet Number

BX

Characteristic Temperature

B

Voltage

103

Capacitance Code

K

Capacitance Tolerance

C

Termination

PART NUMBER CODES

Voltage-Temperature Limits:

Symbol	Capacitance change with reference to 25°C over temperature range -55°C to +125°C	
	Without Voltage	With Rated DC Voltage
BP	0 ± 30 ppm/°C	0 ± 30 ppm/°C
BX	+15, -15 percent	+15, -25 percent

Rated Voltage:

Symbol	Rated Voltage Volts, DC
B	50
C	100

Capacitance Tolerance:

Symbol	Cap. Tolerance ±
C	0.25pF
D	0.5 pF
E	1%
J	5%
K	10%

Termination:

Lead Capacitors	
Symbol	Termination Style
C	Copper, solder coated (type C-4 or C-5 of MIL-STD-1276)
W	Copper clad steel, solder coated, 60 micro inches minimum.

CROSS REFERENCE MIL-SPEC TEST REQUIREMENTS

TEST DESCRIPTION	MIL-PRF-123	MIL-PRF-39014	MIL-PRF-20	MIL-PRF-55681
NDT (Non-Destructive Test)	100% Ultrasonic Scan or Neutron-Radiography	No	No	No
Pre-Cap Visual (Pre-Encapsulation Visual Examination)	100%	No	No	No
D.P.A. (Destructive Physical Analysis)	Lot by Lot — Pre-Termination Lot by Lot — Finished Product	No	No	No
Pre-Cap Terminal Strength (Pre-Encapsulation Pull Test)	Lot by Lot	No	No	No
Life Test (Lot by Lot)	Lot by Lot — 1000 Hours	No	No	No
Low Voltage Humidity	Lot by Lot	No	No	No
Thermal Shock 100 Cycles	Lot by Lot	No	No	No

Military Ceramic Leaded Capacitors



MIL-PRF-123/01, /02, /04, /05, /06, /07, /08, /16, /17, /18

MIL-PRF-123/STYLE CKS05, -/01

Part Number 1/	Capacitance pF	Capacitance Tolerance	Voltage-Temperature Limits	Rated Voltage
M123A01BPC4R7_C	4.7	C, D	BP	100
M123A01BPC5R1_C	5.1			
M123A01BPC5R6_C	5.6			
M123A01BPC6R2_C	6.2			
M123A01BPC6R8_C	6.8			
M123A01BPC7R5_C	7.5			
M123A01BPC8R2_C	8.2			
M123A01BPC9R1_C	9.1			
M123A01BPC100_C	10			
M123A01BPC110_C	11			
M123A01BPC120_C	12			
M123A01BPC130_C	13			
M123A01BPC150_C	15			
M123A01BPC160_C	16			
M123A01BPC180_C	18			
M123A01BPC200_C	20			
M123A01BPC220_C	22			
M123A01BPC240_C	24			
M123A01BPC270_C	27			
M123A01BPC300_C	30			
M123A01BPC330_C	33	F, J, K	BP	100
M123A01BPC360_C	36			
M123A01BPC390_C	39			
M123A01BPC430_C	43			
M123A01BPC470_C	47			
M123A01BPC510_C	51			
M123A01BPC560_C	56			
M123A01BPC620_C	62			
M123A01BPC680_C	68			
M123A01BPC750_C	75			
M123A01BPC820_C	82			
M123A01BPC910_C	91			
M123A01BPC101_C	100			
M123A01BPC111_C	110			
M123A01BPC121_C	120			
M123A01BPC131_C	130			
M123A01BPC151_C	150			
M123A01BPC161_C	160			
M123A01BPC181_C	180			
M123A01BPC201_C	200			
M123A01BPC221_C	220	F, J, K	BP	100
M123A01BPC241_C	240			
M123A01BPC271_C	270			
M123A01BPC301_C	300			
M123A01BPC331_C	330			
M123A01BPC361_C	360			
M123A01BPC391_C	390			
M123A01BPC431_C	430			
M123A01BPC471_C	470			
M123A01BPC511_C	510			
M123A01BPC561_C	560			
M123A01BPC621_C	620			
M123A01BPC681_C	680			
M123A01BPC751_C	750			
M123A01BPC821_C	820			
M123A01BPC911_C	910			
M123A01BPC102_C	1,000			
M123A02BPC112_C	1,100			
M123A02BPC122_C	1,200			
M123A02BPC132_C	1,300			
M123A02BPC152_C	1,500	F, J, K	BP	100
M123A02BPC162_C	1,600			
M123A02BPC182_C	1,800			
M123A02BPC202_C	2,000			
M123A02BPC222_C	2,200			
M123A02BPC242_C	2,400			
M123A02BPC272_C	2,700			
M123A01BPC282_C	2,800			
M123A01BPC302_C	3,000			
M123A01BPC332_C	3,300			
M123A01BPC362_C	3,600			
M123A01BPC392_C	3,900			
M123A02BPC432_C	4,300			
M123A02BPC472_C	4,700			
M123A02BXC562KC	5,600			
M123A02BXC682KC	6,800			
M123A02BXC822KC	8,200			
M123A02BXC103KC	10,000			
M123A02BXC123KC	12,000			
M123A02BXC153KC	15,000			
M123A02BXC183KC	18,000	K	BX	100
M123A02BXC223KC	22,000			
M123A02BXC273KC	27,000			
M123A02BXC333KC	33,000			
M123A02BXC393KC	39,000			
M123A02BXC473KC	47,000			
M123A02BXC563KC	56,000			
M123A02BXC683KC	68,000			
M123A02BXC823KC	82,000			
M123A02BXC104KC	100,000			
M123A02BXC154KC	150,000			
M123A02BXC184KC	180,000			
M123A02BXC224KC	220,000			
M123A02BXC274KC	270,000			
M123A02BXC334KC	330,000			
M123A02BXC394KC	390,000			
M123A02BXC474KC	470,000			

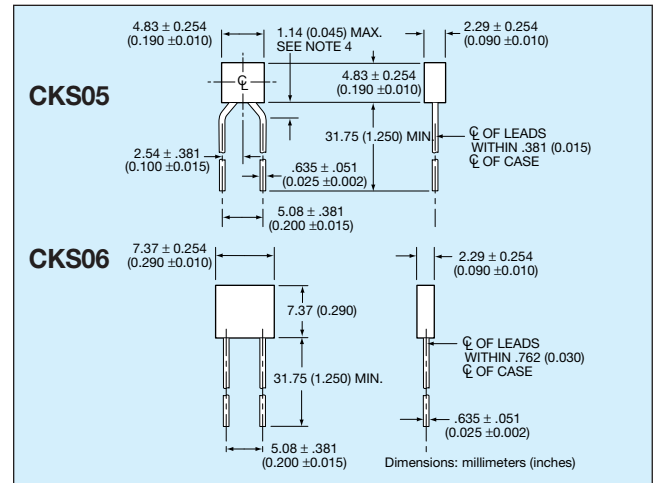

MIL-PRF-123/STYLE CKS06, -/02

Part Number 1/	Capacitance pF	Capacitance Tolerance	Voltage-Temperature Limits	Rated Voltage
M123A02BPC271_C	270	F, J, K	BP	100
M123A02BPC301_C	300			
M123A02BPC331_C	330			
M123A02BPC361_C	360			
M123A02BPC391_C	390			
M123A02BPC431_C	430			
M123A02BPC471_C	470			
M123A02BPC511_C	510			
M123A02BPC561_C	560			
M123A02BPC621_C	620			
M123A02BPC681_C	680			
M123A02BPC751_C	750			
M123A02BPC821_C	820			
M123A02BPC911_C	910			
M123A02BPC102_C	1,000			
M123A02BPC112_C	1,100			
M123A02BPC122_C	1,200			
M123A02BPC132_C	1,300			
M123A02BPC152_C	1,500			
M123A02BPC162_C	1,600			
M123A02BPC182_C	1,800	F, J, K	BP	100
M123A02BPC202_C	2,000			
M123A02BPC222_C	2,200			
M123A02BPC242_C	2,400			
M123A02BPC272_C	2,700			
M123A02BPC302_C	3,000			
M123A02BPC332_C	3,300			
M123A02BPC362_C	3,600			
M123A02BPC392_C	3,900			
M123A02BPC432_C	4,300			
M123A02BPC472_C	4,700			
M123A02BXC562KC	5,600			
M123A02BXC682KC	6,800			
M123A02BXC822KC	8,200			
M123A02BXC103KC	10,000			
M123A02BXC123KC	12,000			
M123A02BXC153KC	15,000			
M123A02BXC183KC	18,000			
M123A02BXC223KC	22,000			
M123A02BXC273KC	27,000			
M123A02BXC333KC	33,000	K	BX	100
M123A02BXC393KC	39,000			
M123A02BXC473KC	47,000			
M123A02BXC563KC	56,000			
M123A02BXC683KC	68,000			
M123A02BXC823KC	82,000			
M123A02BXC104KC	100,000			
M123A02BXC154KC	150,000			
M123A02BXC184KC	180,000			
M123A02BXC224KC	220,000			
M123A02BXC274KC	270,000			
M123A02BXC334KC	330,000			
M123A02BXC394KC	390,000			
M123A02BXC474KC	470,000			



Military Ceramic Leaded Capacitors



MIL-PRF-123/01, /02, /04, /05, /06, /07, /08, /16, /17, /18

millimeters (inches)

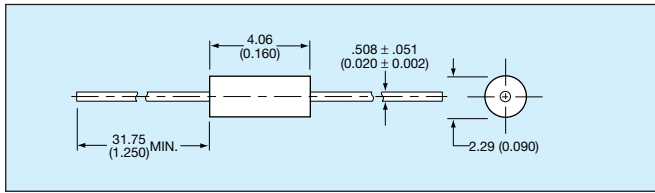

millimeters (inches)

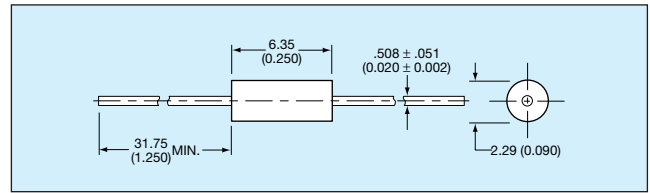

MIL-PRF-123/STYLE CKS11, -/04

Part Number 1/	Capacitance pF	Capacitance Tolerance	Voltage-Temperature Limits	Rated Voltage
M123A04BPC4R7_W M123A04BPC5R1_W M123A04BPC6R2_W M123A04BPC6R8_W M123A04BPC7R5_W	4.7 5.1 6.2 6.8 7.5	C, D	BP	100
M123A04BPC8R2_W M123A04BPC9R1_W M123A04BPC100_W M123A04BPC110_W M123A04BPC120_W	8.2 9.1 10 11 12	C, J, K		
M123A04BPC130_W M123A04BPC150_W M123A04BPC160_W M123A04BPC180_W M123A04BPC200_W	13 15 16 18 20			
M123A04BPC220_W M123A04BPC240_W M123A04BPC270_W M123A04BPC300_W M123A04BPC330_W	22 24 27 30 33			
M123A04BPC360_W M123A04BPC390_W M123A04BPC430_W M123A04BPC470_W M123A04BPC510_W	36 39 43 47 51			
M123A04BPC560_W M123A04BPC620_W M123A04BPC680_W M123A04BPC750_W M123A04BPC820_W	56 62 68 75 82			
M123A04BPC910_W M123A04BPC101_W	91 100	C, J, K	BP	100
M123A04BPP111_W M123A04BPP121_W M123A04BPP131_W M123A04BPP151_W M123A04BPP161_W	110 120 130 150 160	F, J, K	BP	50
M123A04BPP181_W M123A04BPP201_W M123A04BPP221_W M123A04BPP241_W M123A04BPP271_W	180 200 220 240 270			
M123A04BPP301_W M123A04BPP331_W M123A04BPP361_W M123A04BPP391_W M123A04BPP431_W	300 330 360 390 430			
M123A04BPP471_W M123A04BPP511_W M123A04BPP561_W	470 510 560	F, J, K	BP	50
M123A04BXC101KW M123A04BXC121KW M123A04BXC151KW M123A04BXC181KW M123A04BXC221KW	100 120 150 180 220	K	BX	100
M123A04BXC271KW M123A04BXC331KW M123A04BXC391KW M123A04BXC471KW M123A04BXC561KW	270 330 390 470 560			
M123A04BXC681KW M123A04BXC821KW M123A04BXC102KW	680 820 1,000	K	BX	100
M123A04BXC122KW M123A04BXC152KW M123A04BXC182KW M123A04BXC222KW M123A04BXC272KW	1,200 1,500 1,800 2,200 2,700			
M123A04BXC332KW M123A04BXC392KW M123A04BXC472KW	3,300 3,900 4,700	K	BX	50

MIL-PRF-123/STYLE CKS12, -/05

Part Number 1/	Capacitance pF	Capacitance Tolerance	Voltage-Temperature Limits	Rated Voltage
M123A05BPC111_W M123A05BPC121_W M123A05BPC131_W M123A05BPC151_W M123A05BPC161_W	110 120 130 150 160	F, J, K	BP	100
M123A05BPC181_W M123A05BPC201_W M123A05BPC221_W	180 200 220	F, J, K	BP	100
M123A05BPP241_W M123A05BPP271_W M123A05BPP301_W M123A05BPP331_W M123A05BPP361_W	240 270 300 330 360	F, J, K	BP	50
M123A05BPP391_W M123A05BPP431_W M123A05BPP471_W	390 430 470	F, J, K	BP	50
M123A05BXC122KW M123A05BXC152KW M123A05BXC182KW M123A05BXC222KW M123A05BXC272KW	1,200 1,500 1,800 2,200 2,700	K	BX	100
M123A05BXC332KW M123A05BXC392KW M123A05BXC472KW	3,300 3,900 4,700	K	BX	100
M123A05BXC562KW M123A05BXC682KW M123A05BXC822KW M123A05BXC103KW	5,600 6,800 8,200 10,000	K	BX	50

millimeters (inches)

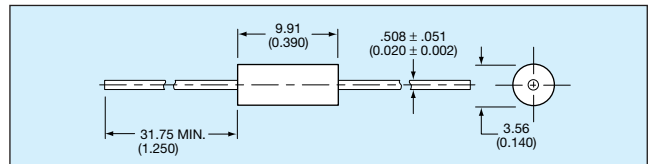

MIL-PRF-123/STYLE CKS14, -/06

Part Number 1/	Capacitance pF	Capacitance Tolerance	Voltage-Temperature Limits	Rated Voltage
M123A06BPC241_W M123A06BPC271_W M123A06BPC301_W M123A06BPC331_W M123A06BPC361_W	240 270 300 330 360	F, J, K	BP	100
M123A06BPC391_W M123A06BPC431_W M123A06BPC471_W M123A06BPC511_W M123A06BPC561_W	390 430 470 510 560			
M123A06BPC621_W M123A06BPC681_W M123A06BPC751_W M123A06BPC821_W M123A06BPC911_W	620 680 750 820 910			
M123A06BPC102_W	1,000	F, J, K	BP	100
M123A06BPP112_W M123A06BPP122_W M123A06BPP132_W M123A06BPP152_W M123A06BPP162_W	1,100 1,200 1,300 1,500 1,600	F, J, K	BP	50
M123A06BPP182_W M123A06BPP202_W M123A06BPP222_W M123A06BPP242_W	1,800 2,000 2,200 2,400	F, J, K	BP	50

Military Ceramic Leaded Capacitors



MIL-PRF-123/01, /02, /04, /05, /06, /07, /08, /16, /17, /18

MIL-PRF-123/STYLE CKS14, -/06 (continued)

Part Number 1/	Capacitance pF	Capacitance Tolerance	Voltage-Temperature Limits	Rated Voltage
M123A06BPP272_W M123A06BPP302_W M123A06BPP332_W M123A06BPP362_W M123A06BPP392_W	2,700 3,000 3,300 3,600 3,900	F, J, K	BP	50
M123A06BPP432_W M123A06BPP472_W M123A06BPP512_W M123A06BPP562_W M123A06BPP622_W	4,300 4,700 5,100 5,600 6,200	↓	↓	↓
M123A06BPP682_W	6,800	F, J, K	BP	50
M123A06BXC562KW M123A06BXC682KW M123A06BXC822KW M123A06BXC103KW	5,600 6,800 8,200 10,000	K	BX	100
M123A06BXC123KW M123A06BXC153KW M123A06BXC183KW M123A06BXC223KW M123A06BXC273KW	12,000 15,000 18,000 22,000 27,000	K	BX	50
M123A06BXC333KW M123A06BXC393KW M123A06BXC473KW	33,000 39,000 47,000	K	BX	50

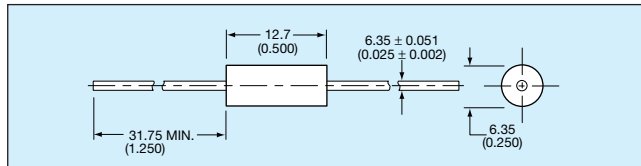
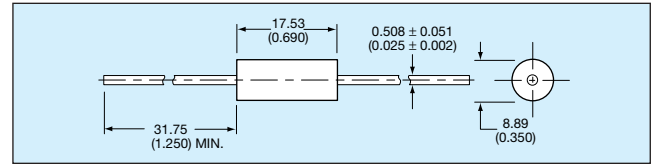

MIL-PRF-123/STYLE CKS15, -/07

Part Number 1/	Capacitance pF	Capacitance Tolerance	Voltage-Temperature Limits	Rated Voltage
M123A07BPC112_W M123A07BPC122_W M123A07BPC132_W M123A07BPC152_W M123A07BPC162_W	1,100 1,200 1,300 1,500 1,600	F, J, K	BP	100
M123A07BPC182_W M123A07BPC202_W M123A07BPC222_W	1,800 2,000 2,200	↓	↓	↓
M123A07BPP242_W M123A07BPP272_W M123A07BPP302_W M123A07BPP332_W M123A07BPP362_W	2,400 2,700 3,000 3,300 3,600	F, J, K	BP	50
M123A07BPP392_W M123A07BPP432_W M123A07BPP472_W M123A07BPP512_W M123A07BPP562_W	3,900 4,300 4,700 5,100 5,600	↓	↓	↓
M123A07BPP622_W M123A07BPP682_W M123A07BPP752_W M123A07BPP822_W M123A07BPP912_W	6,200 6,800 7,500 8,200 9,100	↓	↓	↓
M123A07BPP103_W M123A07BPP113_W M123A07BPP123_W M123A07BPP133_W M123A07BPP153_W	10,000 11,000 12,000 13,000 15,000	↓	↓	↓
M123A07BPP163_W M123A07BPP183_W M123A07BPP203_W M123A07BPP223_W	16,000 18,000 20,000 22,000	F, J, K	BP	50
M123A07BXC123KW M123A07BXC153KW M123A07BXC183KW M123A07BXC223KW M123A07BXC273KW	12,000 15,000 18,000 22,000 27,000	K	BX	100
M123A07BXC333KW M123A07BXC393KW M123A07BXC473KW M123A07BXC563KW M123A07BXC683KW M123A07BXC823KW	33,000 39,000 47,000 56,000 68,000 82,000	↓	↓	↓
M123A07BXC104KW	100,000	K	BX	100
M123A07BXC124KW M123A07BXC154KW M123A07BXC184KW	120,000 150,000 180,000	K	BX	50 ↓ ↓

MIL-PRF-123/STYLE CKS16, -/08

Part Number 1/	Capacitance pF	Capacitance Tolerance	Voltage-Temperature Limits	Rated Voltage
M123A08BPC242_W M123A08BPC272_W M123A08BPC302_W M123A08BPC332_W	2,400 2,700 3,000 3,300	F, J, K	BP	100
M123A08BPC362_W M123A08BPC392_W M123A08BPC432_W M123A08BPC472_W M123A08BPC512_W	3,600 3,900 4,300 4,700 5,100	↓	↓	↓
M123A08BPC562_W M123A08BPC622_W M123A08BPC682_W M123A08BPC822_W M123A08BPC912_W	5,600 6,200 6,800 8,200 9,100	↓	↓	↓
M123A08BPC103_W	10,000	F, J, K	BP	100
M123A08BPP113_W M123A08BPP123_W M123A08BPP133_W M123A08BPP153_W M123A08BPP163_W	11,000 12,000 13,000 15,000 16,000	F, J, K	BP	50
M123A08BPP183_W M123A08BPP203_W M123A08BPP223_W	18,000 20,000 22,000	↓	↓	↓
M123A08BXC124KW M123A08BXC154KW M123A08BXC184KW M123A08BXC224KW M123A08BXC274KW	120,000 150,000 180,000 220,000 270,000	K	BX	100
M123A08BXC334KW M123A08BXC394KW M123A08BXC474KW	330,000 390,000 470,000	K	BX	100
M123A08BXC564KW M123A08BXC684KW M123A08BXC824KW M123A08BXC105KW	560,000 680,000 820,000 1,000,000	K	BX	50 ↓ ↓ ↓



Military Ceramic Leaded Capacitors



MIL-PRF-123/01, /02, /04, /05, /06, /07, /08, /16, /17, /18

STYLE CKS22, -/16

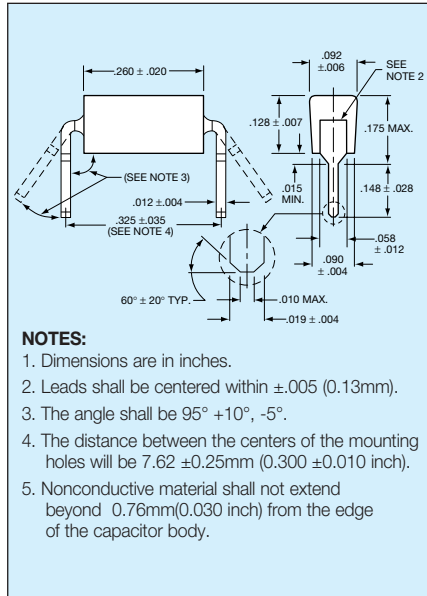

STYLE CKS23, -/17

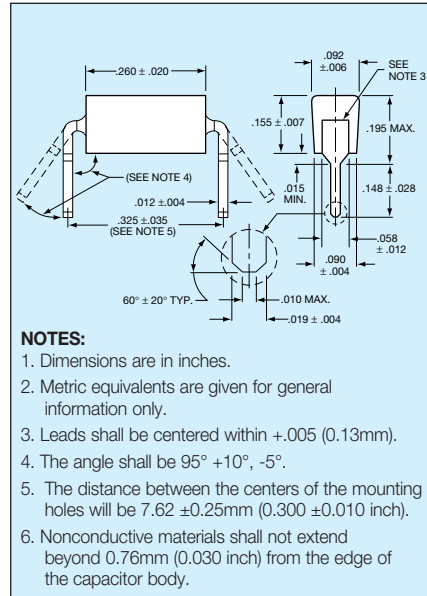

STYLE CKS24, -/18

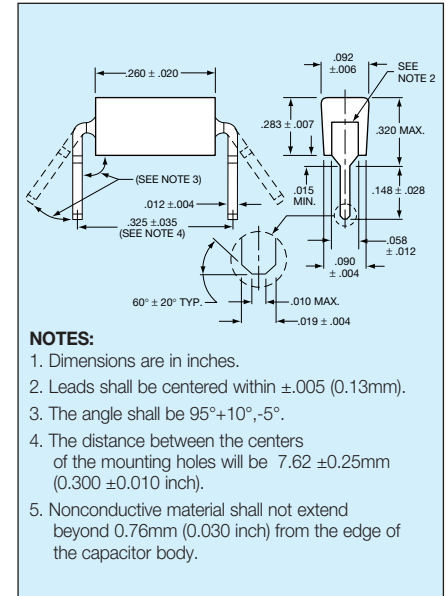

MIL-PRF-123/STYLE CKS22, -/16

Part Number 1/	Capacitance pf	Capacitance Tolerance	Voltage-Temperature Limits	Rated Voltage
M123A16BPD1R0DC	1.0	D	BP	200
M123A16BPD1R2DC	1.2			
M123A16BPD1R5DC	1.5			
M123A16BPD1R8DC	1.8			
M123A16BPD2R2DC	2.2			
M123A16BPD2R7DC	2.7			
M123A16BPD3R3DC	3.3			
M123A16BPD3R9DC	3.9			
M123A16BPD4R7DC	4.7			
M123A16BPD5R6DC	5.6			
M123A16BPD6R8DC	6.8			
M123A16BPD8R2DC	8.2			
M123A16BPD100.C	10			
M123A16BPD120.C	12			
M123A16BPD150.C	15			
M123A16BPD180.C	18			
M123A16BPD220.C	22			
M123A16BPD270.C	27			
M123A16BPD330.C	33			
M123A16BPD390.C	39			
M123A16BPD470.C	47			
M123A16BPD560.C	56			
M123A16BPD680.C	68			
M123A16BPD820.C	82			
M123A16BPD101.C	100			
M123A16BPD121.C	120			
M123A16BPD151.C	150			
M123A16BPD181.C	180			
M123A16BPD221.C	220			
M123A16BPD271.C	270			
M123A16BPD331.C	330			
M123A16BPD391.C	390			
M123A16BPD471.C	470	F, J, K	BP	200
M123A16BPC361.C	560	F, J, K	BP	100
M123A16BPC681.C	680			
M123A16BPC821.C	820			
M123A16BPC102.C	1000			
M123A16BPC122.C	1200			
M123A16BPC152.C	1500			
M123A16BPC182.C	1800			
M123A16BPC222.C	2200	F, J, K	BP	100
M123A16BPB272.C	2700	F, J, K	BP	50
M123A16BPB332.C	3300			
M123A16BPB392.C	3900			
M123A16BPB472.C	4700	F, J, K	BP	50
M123A16BXD271KC	270	K	BX	200
M123A16BXD331.C	330	K, M		
M123A16BXD391KC	390	K		
M123A16BXD471.C	470	K, M		
M123A16BXD561KC	560	K		
M123A16BXD681.C	680	K, M		
M123A16BXD821KC	820	K	BX	200
M123A16BXC102.C	1000	K, M	BX	100
M123A16BXC122KC	1200	K		
M123A16BXC152.C	1500	K, M		
M123A16BXC182KC	1800	K		
M123A16BXC222.C	2200	K, M	BX	100

Part Number 1/	Capacitance pf	Capacitance Tolerance	Voltage-Temperature Limits	Rated Voltage
M123A16BXC272KC	2700	K	BX	100
M123A16BXC332.C	3300	K, M		
M123A16BXC392KC	3900	K		
M123A16BXC472.C	4700	K, M		
M123A16BXC562KC	5600	K		
M123A16BXC682.C	6800	K, M		
M123A16BXC822KC	8200	K		
M123A16BXC103.C	10000	K, M	BX	100
M123A16BXB123KC	12000	K	BX	50
M123A16BXB153.C	15000	K, M		
M123A16BXB183KC	18000	K		
M123A16BXB223.C	22000	K, M		
M123A16BXB273KC	27000	K		
M123A16BXB333.C	33000	K, M		
M123A16BXB393KC	39000	K		
M123A16BXB473.C	47000	K, M		
M123A16BXB563KC	56000	K		
M123A16BXB683.C	68000	K, M		
M123A16BXB823KC	82000	K		
M123A16BXB104.C	100000	K, M	BX	50

1/The complete part number shall include a symbol to indicate capacitance tolerance, as applicable.

MIL-PRF-123/STYLE CKS23, -/17

Part Number 1/	Capacitance pf	Capacitance Tolerance	Voltage-Temperature Limits	Rated Voltage
M123A17BPD561.C	560	F, J, K	BP	200
M123A17BPD681.C	680			
M123A17BPD821.C	820			
M123A17BPD102.C	1000			
M123A17BPD122.C	1200	F, J, K	BP	200
M123A17BPC272.C	2700	F, J, K	BP	100
M123A17BPC332.C	3300	F, J, K	BP	100
M123A17BPC472.C	4700	F, J, K	BP	50
M123A17BPC562.C	5600			
M123A17BPC682.C	6800			
M123A17BPC822.C	8200			
M123A17BPC103.C	10000	F, J, K	BP	50
M123A17BXD102.C	1000	K, M	BX	200
M123A17BXD122KC	1200	K		
M123A17BXD152.C	1500	K, M		
M123A17BXD182KC	1800	K		
M123A17BXD222.C	2200	K, M		
M123A17BXD272KC	2700	K		
M123A17BXD332.C	3300	K, M		
M123A17BXD392KC	3900	K		
M123A17BXD472.C	4700	K, M		
M123A17BXD562KC	5600	K		
M123A17BXD682.C	6800	K, M		
M123A17BXD822KC	8200	K		
M123A17BXD103.C	10000	K, M	BX	200
M123A17BXC123KC	12000	K	BX	100
M123A17BXC153.C	15000	K, M		
M123A17BXC183KC	18000	K		
M123A17BXC223.C	22000	K, M		
M123A17BXC273KC	27000	K	BX	100

Part Number 1/	Capacitance pf	Capacitance Tolerance	Voltage-Temperature Limits	Rated Voltage
M123A17BXC333.C	33000	K, M	BX	100
M123A17BXC393KC	39000	K		
M123A17BXC473.C	47000	K, M		
M123A17BXC563KC	56000	K		
M123A17BXC683.C	68000	K, M		
M123A17BXC823KC	82000	K		
M123A17BXC104.C	100000	K, M	BX	100
M123A17BXC124KC	120000	K	BX	50
M123A17BXC154.C	150000	K, M		
M123A17BXC184KC	180000	K, M		
M123A17BXC224.C	220000	K, M	BX	50

1/The complete part number shall include a symbol to indicate capacitance tolerance, as applicable.

MIL-PRF-123/STYLE CKS24, -/18

Part Number 1/	Capacitance pf	Capacitance Tolerance	Rated Voltage Limits
M123A18BRC124KC	120000	K	100
M123A18BRC154.C	150000	K, M	100
M123A18BRB184KC	180000	K	50
M123A18BRB224.C	220000	K, M	
M123A18BRB274KC	270000	K, M	
M123A18BRB334.C	330000	K, M	
M123A18BRB394KC	390000	K	
M123A18BRB474.C	470000	K, M	50

1/The complete part number shall include a symbol to indicate capacitance tolerance, as applicable.



Military Ceramic Leaded Capacitors



MIL-PRF-123

MARKING

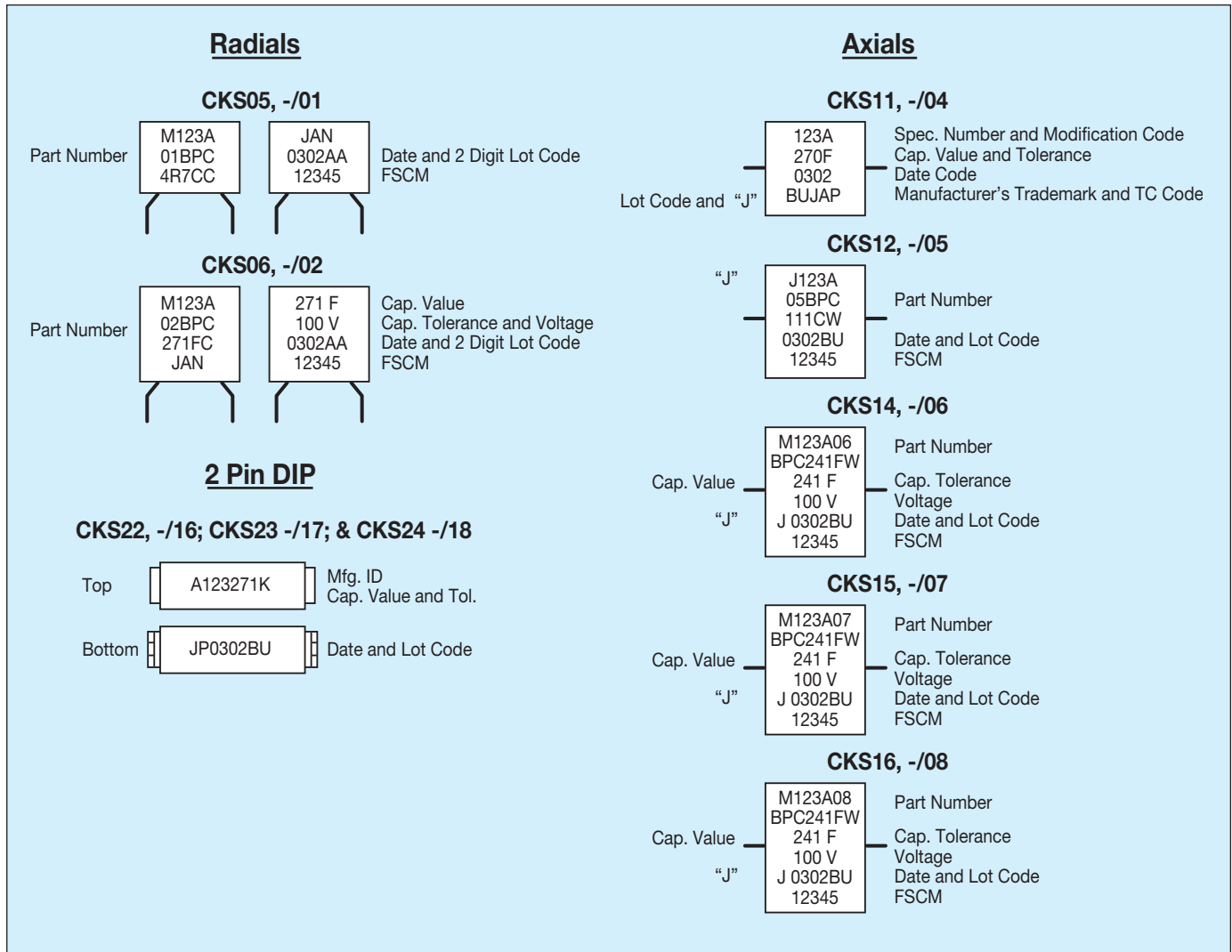

Military Ceramic Leaded Capacitors



Radial Leads Packaging / Tape and Reel

GENERAL INFORMATION

- Standard reel diameter is 355 millimeters (14 inches) maximum.
- Reeling standard (#1 or #2) should be specified when ordering.

STANDARD 1

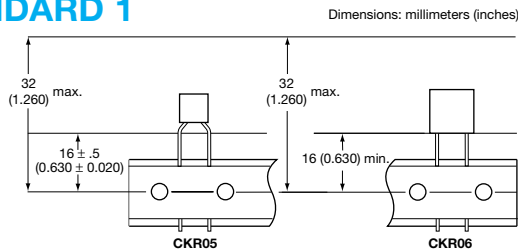

STANDARD 2

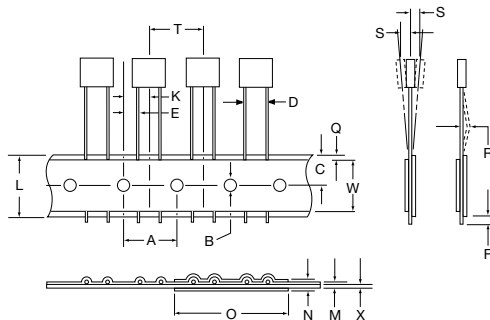
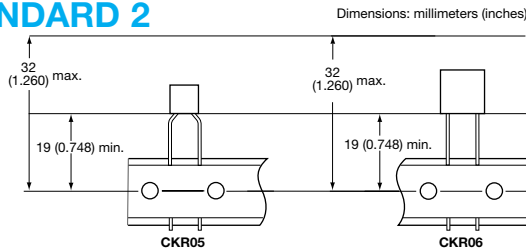

DESCRIPTION	DIMENSIONS millimeters (inches)
A. Feed Hole Pitch	12.70 (0.500) ± .20 (0.008)
B. Feed Hole Diameter	3.99 (0.157) ± .20 (0.008)
C. Feed Hole Location	9.02 (0.355) ± .51 (0.020)
D. Component Lead Spacing	5.00 (0.197) +.79 (0.031) - .20 (0.008) or 2.54 +.79 (0.031) - .20 (0.008)
E. Component Lead Location	3.81 (0.150) ± .51 (0.020) or 5.00 (0.197) ± .51 (0.200) for 2.54 lead spacing
F. Component Lead Protrusion (edge of carrier to cut end of lead)	2.00 (0.079) maximum
K. Component Body Location	6.35 (0.025) ± .41 (0.016)
L. Carrier Tape Width	18.01 (0.709) +1.02 (0.040) - .51 (0.020)
M. Carrier Tape Assembly Thickness	.71 (0.028) ± .20 (0.008)
N. Carrier Tape Spliced Thickness	1.42 (0.056) maximum
O. Carrier Tape Spliced Length	50.80 (2.00) - 88.90 (3.50)
Q. Adhesive Tape Border	3.00 (0.118) maximum
R. Component Bent Leads (either direction)	.79 (0.031) maximum
S. Component Misalignment	.99 (0.039) maximum
T. Component Pitch	12.70 (0.500) ± .99 (0.039)
W. Adhesive Tape Width	5.00 (0.197) minimum
X. Carrier Tape Thickness	.51 (0.020) ± .10 (0.004)
Y. Cumulative Pitch over 20 Pitches	254 (10.00) ± 2.00 (0.078)

REEL DIRECTION

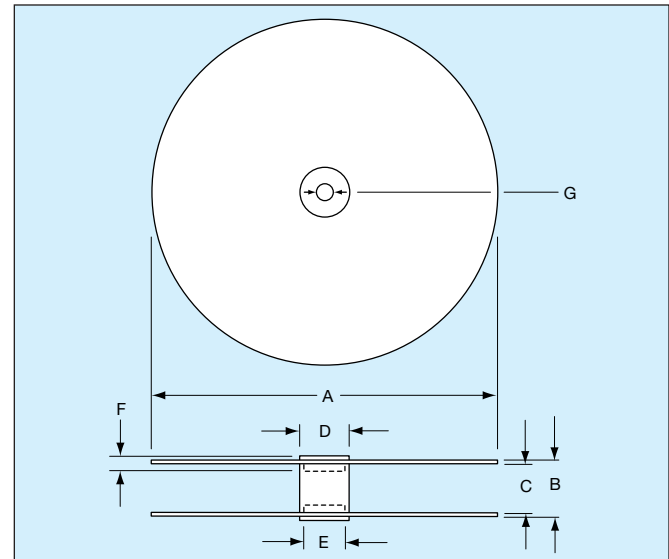
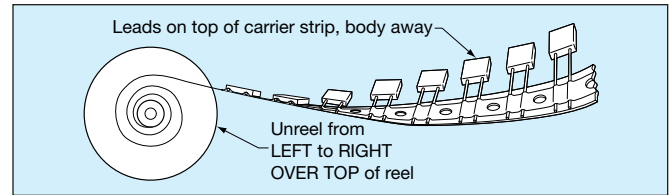

DESCRIPTION	DIMENSIONS millimeters (inches)
A. Reel Diameter	304.80 (12.00) - 355 (13.98)
B. Reel Outside Width	50.80 (0.200) maximum
C. Reel Inside Width	38.10 (1.500) - 46.02 (1.812)
D. Core Diameter (O.D.)	102.01 (4.016) maximum
E. Hub Recess Diameter	86.36 (3.400) maximum
F. Hub Recess Depth	9.50 (0.374) minimum
G. Arbor Hole Diameter	25.40 (1.000) - 30.48 (1.200)

2 PIN DIP PACKAGING:

200 pieces per slide pack*

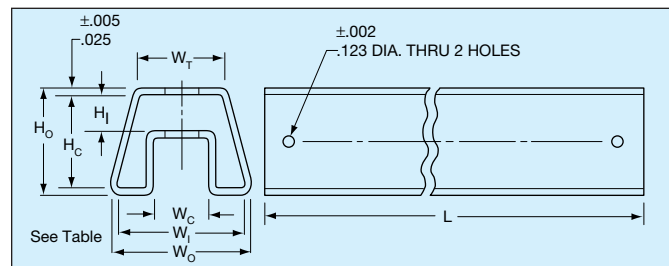

SLIDE PACKAGE DIMENSIONS

	CKR22	CKR23
(H ₀) Overall Height	.400 (0.016) ref.	.430 (0.017) ref.
(H _c) Channel Height	.141 (0.006) ± .006 (.0002)	.171 (0.007) ± .006 (.0002)
(H ₁) Inside Height	.350 (0.014)	.380 (0.015)
(W ₀) Overall Width	.540 (0.021) ref.	.540 (0.021) ref.
(W _i) Inside Width	.490 (0.019)	.490 (0.019)
(W _c) Channel Width	.210 (0.008)	.210 (0.008)
(W _t) Top Width	.350 (0.014)	.310 (0.012)
(L) Length	20.073 (0.790) ± .06 (0.002)	20.073 (0.790) ± .06 (0.002)

*Note: CKR24 are packaged in reels of 200 pieces

Military Ceramic Leaded Capacitors



Axial Leads Packaging / Tape and Reel

TAPE AND REEL

CLASS I / RS-296	
A.	5 ± 0.5 (0.200 ± 0.020)
B*	52.4 ± 1.5 (2.063 ± 0.059)
C.	6.35 ± 0.4 (0.250 ± 0.016)
D ¹ -D ² .	1.4 (0.055) MAX.
E.	1.2 (0.047) MAX.
F.	1.6 (0.063) MAX.
G.	356 (14.00)
H.	76 (3.000)
I.	25.4 (1.000)
J.	84 (3.300)
K.	70 (2.750)

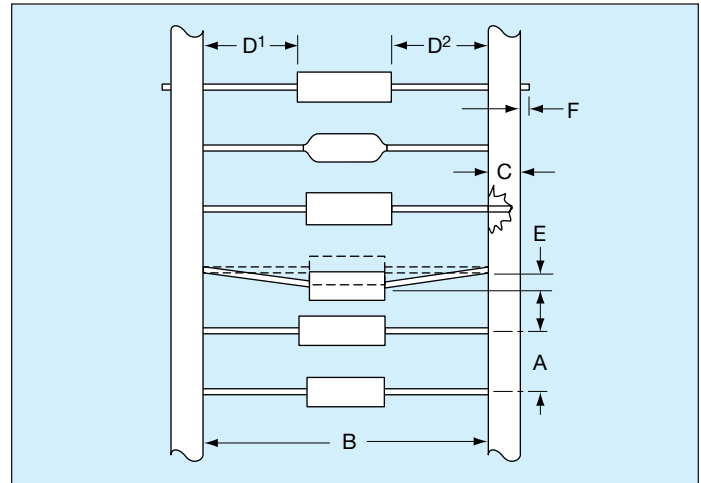

Leader Tape: 300mm min. (12")

Splicing: Tape Only

Missing Parts: 0.25% of component count max.-
No consecutive missing parts

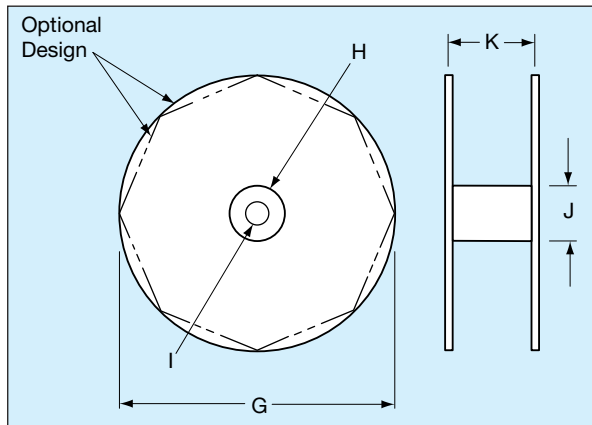

REEL QUANTITIES (MAX.) ‡

MA10	5,000 pcs.	MA40	3,000 pcs.
MA20	5,000 pcs.	MA50	950 pcs.
MA30	3,000 pcs.	MA60	650 pcs.

‡ 1000 pc. reels available for distribution pack only in ±1% and ±2% tolerance.

* Standard Tape Spacing Shown. Also available in 26.0mm + 1.5mm, - 0mm, (1.023 in. + .059 in. - 0 in.) for SpinGuards only. EIA Class I, II and III tape spacings are available for molded axials. Tape spacing for Class II is 63.5mm ± 1.5mm (2.50 in. ± .059 in.), and for Class III 73mm ± 1.5mm (2.87 in. ± .059 in.)

BULK PACK (MOLDED AXIALS ONLY)

MA10	100 pcs. (bag)	MA40	100 pcs. (bag)
MA20	100 pcs. (bag)	MA50	50 pcs. (bag)
MA30	100 pcs. (bag)	MA60	50 pcs. (bag)

Military Glass Capacitors



Glass/Glass-K Capacitors

GLASS CAPACITOR MIL-PRF-23269 ESTABLISHED RELIABILITY

M AND S FAILURE RATE LEVEL

100V, 300V, 500V

Style CYR10, CYR15, CYR20, CYR30
CYR51, CYR52, CYR53

Slash Sheets

/01, 3001-3126, 7001-7126
/02, 3001-3057, 7001-7057
/03, 3001-3072, 7001-7057
/04, 3001-3036, 7001-7021
/10, 3001-3150, 3201-3218, 3301-3327

MIL-PRF-11272

300V, 500V

Style CY10, CY15, CY20, CY30, CY06, CY07, CY08

Slash Sheets /01, /02, /03, /04, /13, /14, /15

GLASS-K CAPACITOR MIL-PRF-11015

50V

Style CK31, CK32

Slash Sheet /25

MIL-PRF-39014

50V

Style CKR31, CKR32

Slash Sheet /21

Glass dielectric capacitors have been the capacitors of choice for extreme long-term stability and reliability for almost fifty years. They are available in glass or glass composition, and are covered by MIL-PRF-11272 and MIL-PRF-23269 or MIL-PRF-11015 and MIL-PRF-39014, respectively.

- **CY Series Glass Dielectric capacitors**, available in both axial and radial configurations, offer the industry's highest performance and maximum stability for aerospace, military and satellite applications which require "S" level reliability, radiation hardness and operating temperatures up to +200°C. Capacitance values range from 0.5 pF to 10,000 pF with tolerances to ±0.5%. Rated voltage is from 50 to 2,000 VDC, with a temperature coefficient of 140±25 ppm/°C. Operating temperature range is -75°C to +200°C.

- **CK Series Glass-K capacitors**, available in axial configurations, offer low noise and low dielectric absorption rate (<0.1%), for digital systems and sensor applications where low loss and stability are required. The Glass-K technology features "M" level reliability, radiation resistance and operating temperatures up to +200°C. Capacitance values range from 270 pF to 100,000 pF (0.1 µF) with tolerances to ±5%. Rated voltage is from 25 to 50 VDC, with three temperature characteristics: +2, -10%; +2, -15% and +20, -45%. Operating temperature range is -75°C to +200°C.

CAPACITORS – MILITARY SPECIFICATION CROSS-REFERENCE

Military Specification	Military Part No.	AVX Part No.	Military Specification	Military Part No.	AVX Part No.
MIL-PRF-11015 (Ceramic Capacitors)	CK31	CK31	MIL-PRF-39014 (Established Reliability) (Ceramic Capacitors)	CKR31	CKR31
	CK32	CK32		CKR32	CKR32
MIL-PRF-11272 (Glass Capacitors)	CY06	CY06	MIL-PRF-23269 (Established Reliability)	CYR10	CYR10
	CY07	CY07		CYR15	CYR15
	CY08	CY08		CYR20	CYR20
	CY10	CY10		CYR30	CYR30
	CY15	CY15		CYR51	CYR51
	CY20	CY20		CYR52	CYR52
	CY30	CY30		CYR53	CYR53

Military Glass Capacitors

MIL-PRF-11272/13, /14, /15
CY06, 07, 08



APPLICATIONS

These precision miniature glass capacitors, AVX style CY0, meet or exceed all requirements of MIL-PRF-11272. Constructed of a fused monolithic capacitive element in a rectangular case with gold-plated radial Dumet leads, this series permits high packaging efficiency for printed circuit applications where extremely stable, low-loss capacitors are required.

PERFORMANCE CHARACTERISTICS

Tolerance: Available tolerances for each value of capacitance are shown in the ordering information table. For codes, refer to the Part Numbers paragraph.

Temperature Coefficient: +140 ±25 ppm/°C at 100 kHz. TC will track and retrace to within ±5 ppm. Capacitance drift is less than 0.1% or 0.1 pF, whichever is greater.

Voltage Coefficient: Zero.

Losses: Extremely low, and remain relatively low at elevated temperatures. Dissipation factor at 1 kHz and 25°C is less than 0.001 for values greater than 100 pF and less than 0.002 for values of 100 pF and below.

Life: After 2,000 hours at 125°C with 150% of rated voltage applied, capacitance change is less than 0.5% or 0.5 pF; dissipation factor is less than 0.0025 for values above 100 pF and less than 0.0045 for values of 100 pF and below.

Insulation Resistance: Greater than 100,000 megohms at 25°C; greater than 10,000 megohms at 125°C.

Voltage/Temperature Rating: 300 WVDC over the temperature range of -55°C to +125°C with no derating required.

Additional performance details are given in the AVX "Performance Characteristics of Multilayer Glass Dielectric Capacitors" technical paper.

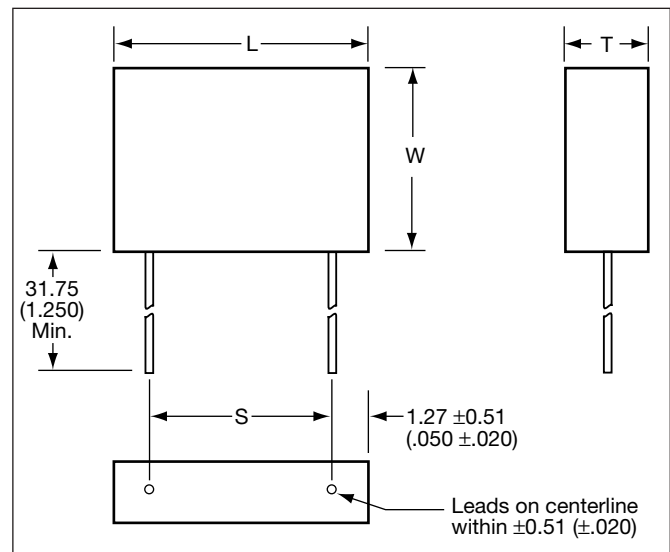
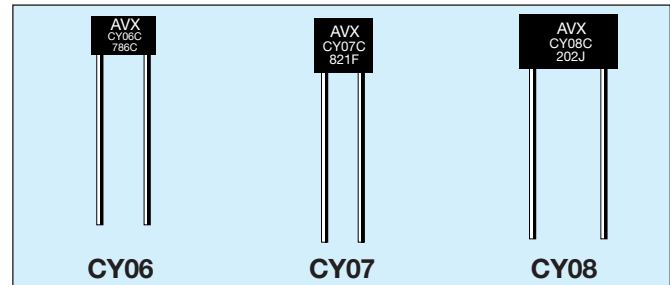

DIMENSIONS:

millimeters (inches)

Case Size	L ±0.13 (±0.005)	W ±0.25 (±0.010)	T ±0.13 (±0.005)	S ±0.51 (±0.020)	Weight (Grams)
CY06	7.62 (0.300)	5.08 (0.200)	2.92 (0.115)	5.08 (0.200)	.3 - .4
CY07	7.62 (0.300)	7.62 (0.300)	2.92 (0.115)	5.08 (0.200)	.4 - .5
CY08	12.70 (0.500)	7.62 (0.300)	2.92 (0.115)	10.16 (0.400)	.7 - .8

Note: All leads are 24 AWG, 0.51 ± .05 (0.020 ± 0.002) diameter. Leads are solderable and weldable gold-plated Dumet, per MIL-STD-1276, Type D.

Military Glass Capacitors

MIL-PRF-11272/13, /14, /15

CY06, 07, 08



HOW TO ORDER

Military Type Designation: Styles CY06, CY07, CY08

Dash Number Option: MIL-PRF-11272/13, 14, 15 (Add Appropriate Dash Number)

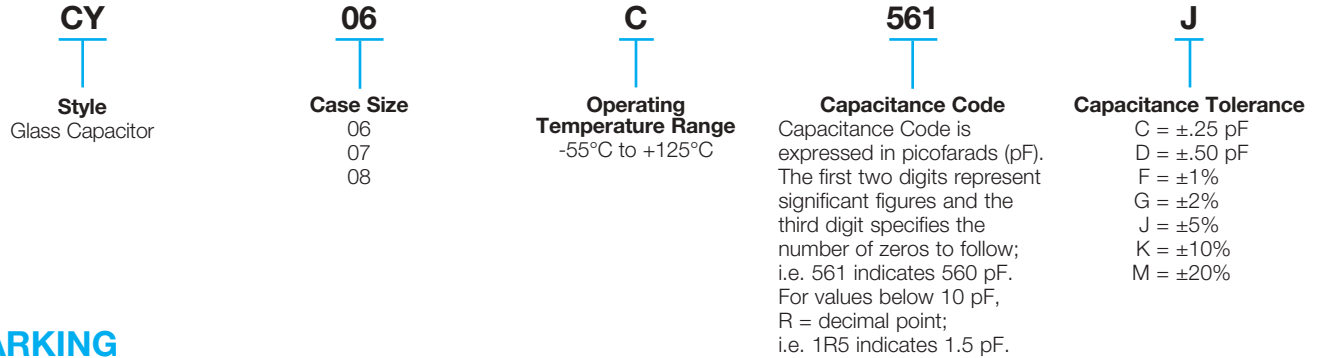

MARKING

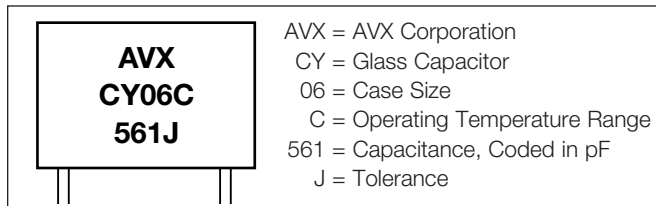

MILITARY PART NUMBER IDENTIFICATION (Standard Values)

Military Type Designation	Capacitance (pF)	Capacitance Tolerance	WVDC
CY06			
CY06C1R0_	1.0	C, D	300
CY06C1R5_	1.5	C, D	300
CY06C2R2_	2.2	C, D	300
CY06C2R7_	2.7	C, D	300
CY06C3R0_	3.0	C, D	300
CY06C3R3_	3.3	C, D	300
CY06C3R6_	3.6	C, D	300
CY06C3R9_	3.9	C, D	300
CY06C4R3_	4.3	C, D	300
CY06C4R7_	4.7	C, K	300
CY06C5R1_	5.1	C, J, K	300
CY06C5R6_	5.6	C, J, K	300
CY06C6R2_	6.2	C, J, K	300
CY06C6R8_	6.8	C, J, K	300
CY06C7R5_	7.5	C, J, K	300
CY06C8R2_	8.2	C, J, K	300
CY06C9R1_	9.1	C, J, K	300
CY06C100_	10	C, J, K, M	300
CY06C110_	11	C, J, K, M	300
CY06C120_	12	C, J, K, M	300
CY06C130_	13	C, G, J, K, M	300
CY06C150_	15	C, G, J, K, M	300
CY06C160_	16	C, G, J, K, M	300
CY06C180_	18	C, G, J, K, M	300
CY06C200_	20	C, G, J, K, M	300
CY06C220_	22	C, G, J, K, M	300
CY06C240_	24	C, G, J, K, M	300
CY06C270_	27	F, G, J, K, M	300
CY06C300_	30	F, G, J, K, M	300
CY06C330_	33	F, G, J, K, M	300
CY06C360_	36	F, G, J, K, M	300
CY06C390_	39	F, G, J, K, M	300
CY06C430_	43	F, G, J, K, M	300
CY06C470_	47	F, G, J, K, M	300
CY06C510_	51	F, G, J, K, M	300
CY06C560_	56	F, G, J, K, M	300
CY06C620_	62	F, G, J, K, M	300
CY06C680_	68	F, G, J, K, M	300
CY06C750_	75	F, G, J, K, M	300
CY06C820_	82	F, G, J, K, M	300

Military Type Designation	Capacitance (pF)	Capacitance Tolerance	WVDC
CY06 (cont)			
CY06C910_	91	F, G, J, K, M	300
CY06C101_	100	F, G, J, K, M	300
CY06C111_	110	F, G, J, K, M	300
CY06C121_	120	F, G, J, K, M	300
CY06C131_	130	F, G, J, K, M	300
CY06C151_	150	F, G, J, K, M	300
CY06C161_	160	F, G, J, K, M	300
CY06C181_	180	F, G, J, K, M	300
CY06C201_	200	F, G, J, K, M	300
CY06C221_	220	F, G, J, K, M	300
CY06C241_	240	F, G, J, K, M	300
CY06C271_	270	F, G, J, K, M	300
CY06C301_	300	F, G, J, K, M	300
CY06C331_	330	F, G, J, K, M	300
CY06C361_	360	F, G, J, K, M	300
CY06C391_	390	F, G, J, K, M	300
CY06C431_	430	F, G, J, K, M	300
CY06C471_	470	F, G, J, K, M	300
CY06C511_	510	F, G, J, K, M	300
CY06C561_	560	F, G, J, K, M	300
CY07			
CY07C621_	620	F, G, J, K, M	300
CY07C681_	680	F, G, J, K, M	300
CY07C751_	750	F, G, J, K, M	300
CY07C821_	820	F, G, J, K, M	300
CY07C911_	910	F, G, J, K, M	300
CY07C102_	1,000	F, G, J, K, M	300
CY08			
CY08C112_	1,100	F, G, J, K, M	300
CY08C122_	1,200	F, G, J, K, M	300
CY08C132_	1,300	F, G, J, K, M	300
CY08C152_	1,500	F, G, J, K, M	300
CY08C162_	1,600	F, G, J, K, M	300
CY08C182_	1,800	F, G, J, K, M	300
CY08C202_	2,000	F, G, J, K, M	300
CY08C222_	2,200	F, G, J, K, M	300
CY08C242_	2,400	F, G, J, K, M	300

—Add letter for tolerance code above lines.

—Add letter for tolerance code above lines.



Military Glass Capacitors

MIL-PRF-11272/01, /02, /03, /04
CY10, 15, 20, 30



APPLICATIONS

These extremely stable glass capacitors, AVX style CY, meet or exceed all requirements of MIL-PRF-11272. With glass dielectric, fused monolithic construction, and true glass-to-metal seals at the leads, they have very low losses and are virtually immune to severe environmental stresses.

PERFORMANCE CHARACTERISTICS

Tolerance: Available tolerances for each value of capacitance are shown in the ordering information table. For codes, refer to the Part Numbers paragraph.

Temperature Coefficient: +140 ±25 ppm/°C at 100 kHz. TC will track and retrace to within ±5 ppm. Capacitance drift is less than 0.1% or 0.1 pF, whichever is greater.

Voltage Coefficient: Zero.

Losses: Extremely low, and remain relatively low at elevated temperatures. Dissipation factor is not more than 0.001 at 1.0 kHz and 25°C.

Life: After 2,000 hours at 125°C with 150% of rated voltage applied, capacitance change is less than 0.5% or 0.5 pF, whichever is greater.

Insulation Resistance: Greater than 100,000 megohms at 25°C; greater than 10,000 megohms at 125°C.

Voltage/Temperature Rating: Voltage ratings are shown in the ordering information table. The operating temperature range is -55°C to +125°C with no derating required.

Moisture Resistance: Meets or exceeds all requirements of MIL-PRF-11272 and MIL-STD-202, Method 106.

Radiation Resistance: The unique materials and construction techniques involved with glass capacitors make them ideal for use in radiation environments. After a total dose of nearly 10⁸ rads (H₂O) glass capacitors exhibit only a minor change in capacitance (≤.5%) and an 8% change in dissipation factor. Furthermore, glass capacitors can operate in fast neutron flux environments of 10¹⁵ N cm⁻²sec⁻¹ and experience little or no damage in component parameters.

Additional performance details are given in the AVX "Performance Characteristics of Multilayer Glass Dielectric Capacitors" technical paper.

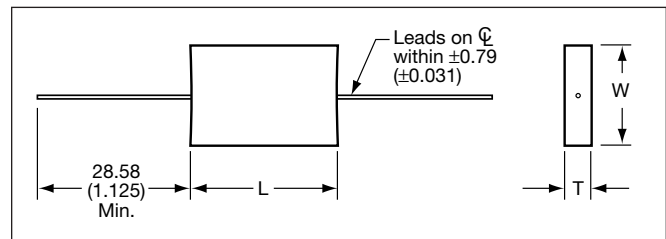
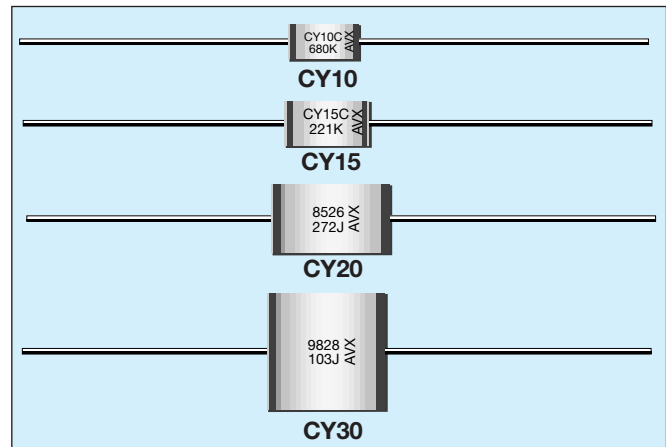

DIMENSIONS:

millimeters (inches)

Case Size	L	W	T	Lead Dia. +0.1 (+0.004) -0.03 (-0.001)	Weight (Grams)
CY10	8.74 ± 1.19 (0.344 ± 0.047)	4.37 ± .79 (0.172 ± 0.031)	1.98 ± .79 (0.078 ± 0.031)	.51 (0.020)	25 – 50
CY15	11.91 ± 1.19 (0.469 ± 0.047)	6.76 ± .79 (0.266 ± 0.031)	2.77 ± 1.19 (0.109 ± 0.047)	.51 (0.020)	75 – 1.25
CY20	18.64 ± 1.57 (0.734 ± 0.062)	10.72 ± 1.19 (0.422 ± 0.047)	3.58 ± 1.19 (0.141 ± 0.047)	.63 (0.025)	2.50 – 4.00
CY30	19.46 ± 1.57 (0.766 ± 0.062)	19.05 ± 1.98 (0.750 ± 0.078)	3.58 ± 1.19 (0.141 ± 0.047)	.63 (0.025)	5.00 – 7.00

Note: Standard leads are solder-coated Dumet.

Military Glass Capacitors

MIL-PRF-11272/01, /02, /03, /04
CY10, 15, 20, 30



HOW TO ORDER

Military Type Designation: Styles CY10, CY15, CY20, CY30

Dash Number Option: MIL-PRF-11272/01, 02, 03, 04 (Add Appropriate Dash Number)

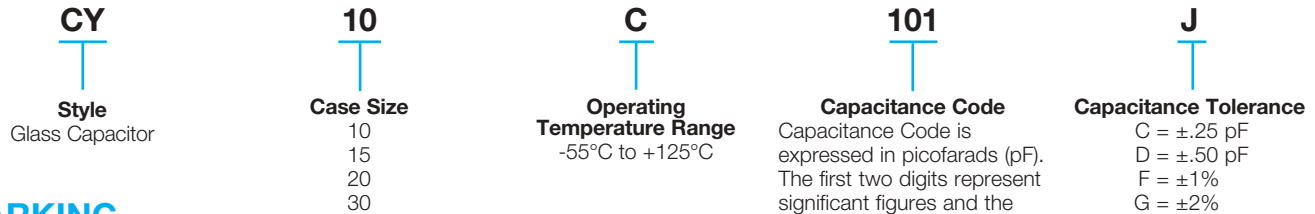

MARKING

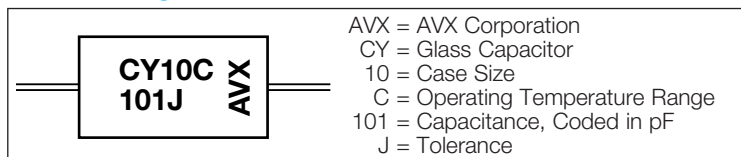

MILITARY PART NUMBER IDENTIFICATION (Standard Values)

Military Type Designation	Cap. (pF)	Cap. Tol.	WVDC
CY10			
CY10C0R5_	0.5	C	500
CY10C1R0_	1.0	C, D	500
CY10C1R5_	1.5	C, D	500
CY10C2R2_	2.2	C, D	500
CY10C2R7_	2.7	C, D	500
CY10C3R0_	3.0	C, D	500
CY10C3R3_	3.3	C, D	500
CY10C3R6_	3.6	C, D	500
CY10C3R9_	3.9	C, D	500
CY10C4R3_	4.3	C, D	500
CY10C4R7_	4.7	C, K	500
CY10C5R1_	5.1	C, J, K	500
CY10C5R6_	5.6	C, J, K	500
CY10C6R2_	6.2	C, J, K	500
CY10C6R8_	6.8	C, J, K	500
CY10C7R5_	7.5	C, J, K	500
CY10C8R2_	8.2	C, J, K	500
CY10C9R1_	9.1	C, J, K	500
CY10C100_	10	C, J, K, M	500
CY10C110_	11	C, J, K, M	500
CY10C120_	12	C, J, K, M	500
CY10C130_	13	C, G, J, K, M	500
CY10C150_	15	C, G, J, K, M	500
CY10C160_	16	C, G, J, K, M	500
CY10C180_	18	C, G, J, K, M	500
CY10C200_	20	C, G, J, K, M	500
CY10C220_	22	C, G, J, K, M	500
CY10C240_	24	C, G, J, K, M	500
CY10C270_	27	F, G, J, K, M	500
CY10C300_	30	F, G, J, K, M	500
CY10C330_	33	F, G, J, K, M	500
CY10C360_	36	F, G, J, K, M	500
CY10C390_	39	F, G, J, K, M	500
CY10C430_	43	F, G, J, K, M	500
CY10C470_	47	F, G, J, K, M	500
CY10C510_	51	F, G, J, K, M	500
CY10C560_	56	F, G, J, K, M	500
CY10C620_	62	F, G, J, K, M	500
CY10C680_	68	F, G, J, K, M	500
CY10C750_	75	F, G, J, K, M	500
CY10C820_	82	F, G, J, K, M	500
CY10C910_	91	F, G, J, K, M	500
CY10C101_	100	F, G, J, K, M	500
CY10C111_	110	F, G, J, K, M	500
CY10C121_	120	F, G, J, K, M	500
CY10C131_	130	F, G, J, K, M	500
CY10C151_	150	F, G, J, K, M	500
CY10C161_	160	F, G, J, K, M	500
CY10C181_	180	F, G, J, K, M	500
CY10C201_	200	F, G, J, K, M	500
CY10C221_	220	F, G, J, K, M	300
CY10C241_	240	F, G, J, K, M	300
CY10C271_	270	F, G, J, K, M	300
CY10C301_	300	F, G, J, K, M	300

—Add letter for tolerance code above lines.

Military Type Designation	Cap. (pF)	Cap. Tol.	WVDC
CY15			
CY15C221_	220	F, G, J, K, M	500
CY15C241_	240	F, G, J, K, M	500
CY15C271_	270	F, G, J, K, M	500
CY15C301_	300	F, G, J, K, M	500
CY15C331_	330	F, G, J, K, M	500
CY15C361_	360	F, G, J, K, M	500
CY15C391_	390	F, G, J, K, M	500
CY15C431_	430	F, G, J, K, M	500
CY15C471_	470	F, G, J, K, M	500
CY15C511_	510	F, G, J, K, M	500
CY15C561_	560	F, G, J, K, M	300
CY15C621_	620	F, G, J, K, M	300
CY15C681_	680	F, G, J, K, M	300
CY15C751_	750	F, G, J, K, M	300
CY15C821_	820	F, G, J, K, M	300
CY15C911_	910	F, G, J, K, M	300
CY15C102_	1,000	F, G, J, K, M	300
CY15C112_	1,100	F, G, J, K, M	300
CY15C122_	1,200	F, G, J, K, M	300
CY20			
CY20C561_	560	F, G, J, K, M	500
CY20C621_	620	F, G, J, K, M	500
CY20C681_	680	F, G, J, K, M	500
CY20C751_	750	F, G, J, K, M	500
CY20C821_	820	F, G, J, K, M	500
CY20C911_	910	F, G, J, K, M	500
CY20C102_	1,000	F, G, J, K, M	500
CY20C112_	1,100	F, G, J, K, M	500
CY20C122_	1,200	F, G, J, K, M	500
CY20C132_	1,300	F, G, J, K, M	500
CY20C152_	1,500	F, G, J, K, M	500
CY20C162_	1,600	F, G, J, K, M	500
CY20C182_	1,800	F, G, J, K, M	500
CY20C202_	2,000	F, G, J, K, M	500
CY20C222_	2,200	F, G, J, K, M	500
CY20C242_	2,400	F, G, J, K, M	500
CY20C272_	2,700	F, G, J, K, M	500
CY20C302_	3,000	F, G, J, K, M	500
CY20C332_	3,300	F, G, J, K, M	500
CY20C362_	3,600	F, G, J, K, M	300
CY20C392_	3,900	F, G, J, K, M	300
CY20C432_	4,300	F, G, J, K, M	300
CY20C472_	4,700	F, G, J, K, M	300
CY20C512_	5,100	F, G, J, K, M	300

—Add letter for tolerance code above lines.

Military Type Designation	Cap. (pF)	Cap. Tol.	WVDC
CY30			
CY30C362_	3,600	F, G, J, K, M	500
CY30C392_	3,900	F, G, J, K, M	500
CY30C432_	4,300	F, G, J, K, M	500
CY30C472_	4,700	F, G, J, K, M	500
CY30C512_	5,100	F, G, J, K, M	500
CY30C562_	5,600	F, G, J, K, M	500
CY30C622_	6,200	F, G, J, K, M	500
CY30C682_	6,800	F, G, J, K, M	300
CY30C752_	7,500	F, G, J, K, M	300
CY30C822_	8,200	F, G, J, K, M	300
CY30C912_	9,100	F, G, J, K, M	300
CY30C103_	10,000	F, G, J, K, M	300

—Add letter for tolerance code above lines.



Military Glass Capacitors

MIL-PRF-23269/10

CYR51, 52, 53



APPLICATIONS

These precision glass-dielectric capacitors are QPL to Established Reliability specification MIL-PRF-23269. Fused monolithic construction provides excellent electrical performance, environmental immunity, stability and retraceability. These capacitors have radial leads.

PERFORMANCE CHARACTERISTICS

Temperature Coefficient: +140 ±25 ppm/°C from -55°C to +125°C. TC of all units will track and retrace to within ±5 ppm.

Life: At rated conditions (100% rated voltage, 125°C), capacitance change is less than:

- ±0.5% after 2,000 hours
- ±2.0% after 30,000 hours

At accelerated conditions (150% rated voltage, 125°C), capacitance change is less than:

- ±0.5% after 2,000 hours
- ±2.0% after 6,000 hours

Insulation Resistance: A minimum of 100,000 megohms at 25°C and 10,000 megohms at 125°C.

Voltage/Temperature Rating: Voltage ratings are shown in the part number tables. The operating temperature range is -55°C to +125°C.

Additional performance details are given in the AVX “Performance Characteristics of Multilayer Glass Dielectric Capacitors” technical paper.

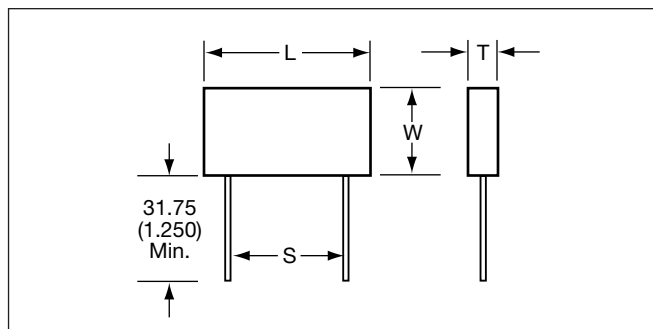
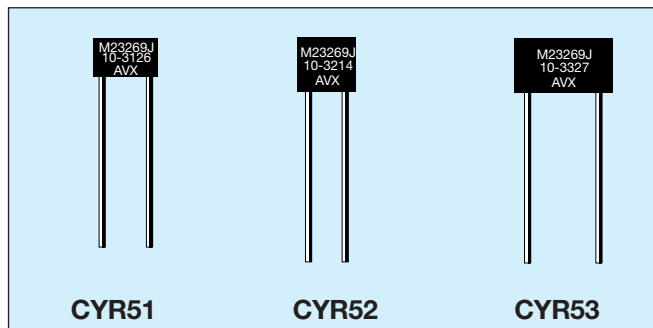

DIMENSIONS: millimeters (inches)

Case Size	L ±0.13 (±0.005)	W ±0.25 (±0.010)	T ±0.13 (±0.005)	S ±0.51 (±0.020)	Lead Dia. ±0.051 (±0.002)
CYR51	7.62 (0.300)	5.08 (0.200)	2.92 (0.115)	5.08 (0.200)	.51 (0.020)
CYR52	7.62 (0.300)	7.62 (0.300)	2.92 (0.115)	5.08 (0.200)	.51 (0.020)
CYR53	12.70 (0.500)	7.62 (0.300)	2.92 (0.115)	10.16 (0.400)	.51 (0.020)

Note: Leads are solderable and weldable gold-plated Dumet, per MIL-STD-1276, Type D.

Military Glass Capacitors

MIL-PRF-23269/10

CYR51, 52, 53



HOW TO ORDER

Military Type Designation: Styles CYR51, CYR52, CYR53

Dash Number Option: MIL-PRF-23269/10 (Add Appropriate Dash Number)

M23269

Style

Military Specification
Established Reliability
Glass Capacitor

10

Case Size

Slash sheet
CYR51
CYR52
CYR53

3

Failure Rate

3 = M level, 1%/1000 hrs.

001

Capacitance Code

Capacitance value
coded in accordance
with MIL-PRF-23269 –
(see Part Number section)

MARKING

CYR51, 52, 53

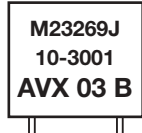

M23269 = Military specification established reliability glass capacitor

J = JAN Trademark

10 = Slash sheet for case sizes –
CYR51, CYR52, CYR53

3 = Failure rate (M level)

001 = Capacitance value coded in
accordance with MIL-PRF-23269

AVX = AVX Corporation

03 = Year

B = Lot Code

CROSS REFERENCE

MIL-PRF-23269 Style	MIL-PRF-11272 Style
CYR10	CY10
CYR15	CY15
CYR20	CY20
CYR30	CY30
CYR51	CY06
CYR52	CY07
CYR53	CY08

MILITARY PART NUMBER IDENTIFICATION

Cap. Value (pF)	Part Number Capacitance Tolerance		
CYR51 M23269/10-			
300 Volts	±.25pF	±2%	±5%
1	3001	—	—
1.5	3002	—	—
2.2	3003	—	—
2.7	3004	—	—
3.0	3005	—	—
3.3	3006	—	—
3.6	3007	—	—
3.9	3008	—	—
4.3	3009	—	—
4.7	3010	—	—
5.1	3011	—	3012
5.6	3013	—	3014
6.2	3015	—	3016
6.8	3017	—	3018
7.5	3019	—	3020
8.2	3021	—	3022
9.1	3023	—	3024
10	3025	—	3026
11	3027	—	3028
12	3029	—	3030
13	3031	3032	3033
15	3034	3035	3036
16	3037	3038	3039
18	3040	3041	3042
20	3043	3044	3045
22	3046	3047	3048
24	3049	3050	3051

*Add first digit to indicate failure rate.

Cap. Value (pF)	Part Number Capacitance Tolerance		
CYR51 M23269/10-			
300 Volts	±1%	±2%	±5%
27	3052	3053	3054
30	3055	3056	3057
33	3058	3059	3060
36	3061	3062	3063
39	3064	3065	3066
43	3067	3068	3069
47	3070	3071	3072
51	3073	3074	3075
56	3076	3077	3078
62	3079	3080	3081
68	3082	3083	3084
75	3085	3086	3087
82	3088	3089	3090
91	3091	3092	3093
100	3094	3095	3096
110	3097	3098	3099
120	3100	3101	3102
130	3103	3104	3105
150	3106	3107	3108
160	3109	3110	3111
180	3112	3113	3114
200	3115	3116	3117
220	3118	3119	3120
240	3121	3122	3123
270	3124	3125	3126
300	3127	3128	3129
330	3130	3131	3132
360	3133	3134	3135
390	3136	3137	3138
430	3139	3140	3141
470	3142	3143	3144
510	3145	3146	3147
560	3148	3149	3150

*Add first digit to indicate failure rate.

Cap. Value (pF)	Part Number Capacitance Tolerance		
CYR52 M23269/10-			
300 Volts	±1%	±2%	±5%
620	3201	3202	3203
680	3204	3205	3206
750	3207	3208	3209
820	3210	3211	3212
910	3213	3214	3215
1,000	3216	3217	3218
CYR53 M23269/10-			
1,100	3301	3302	3303
1,200	3304	3305	3306
1,300	3307	3308	3309
1,500	3310	3311	3312
1,600	3313	3314	3315
1,800	3316	3317	3318
2,000	3319	3320	3321
2,200	3322	3323	3324
2,400	3325	3326	3327

*Add first digit to indicate failure rate.

Military Glass Capacitors

MIL-PRF-23269/01, /02, /03, /04

CYR10, 15, 20, 30



APPLICATIONS

These precision glass-dielectric capacitors are QPL to Established Reliability specification MIL-PRF-23269. Fused monolithic construction provides excellent electrical performance, environmental immunity, stability and retraceability. These capacitors have axial leads.

PERFORMANCE CHARACTERISTICS

Temperature Coefficient: +140 ±25 ppm/°C from -55°C to +125°C. TC of all units will track and retrace to within ±5 ppm.

Life: At rated conditions (100% rated voltage, 125°C), capacitance change is less than:

- ±0.5% after 2,000 hours
- ±2.0% after 30,000 hours

At accelerated conditions (150% rated voltage, 125°C), capacitance change is less than:

- ±0.5% after 2,000 hours
- ±2.0% after 6,000 hours

Insulation Resistance: A minimum of 100,000 megohms at 25°C and 10,000 megohms at 125°C.

Voltage/Temperature Rating: Voltage ratings are shown in the part number tables. The operating temperature range is -55°C to +125°C.

Radiation Resistance: The unique materials and construction techniques involved with glass capacitors make them ideal for use in radiation environments. After a total dose of nearly 10⁸ rads (H₂O) glass capacitors exhibit only a minor change in capacitance (≤.5%) and an 8% change in dissipation factor. Furthermore, glass capacitors can operate in fast neutron flux environments of 10¹⁵ N cm⁻²sec⁻¹ and experience little or no damage in component parameters.

Voltage Coefficient: Zero.

Additional performance details are given in the AVX "Performance Characteristics of Multilayer Glass Dielectric Capacitors" technical paper.

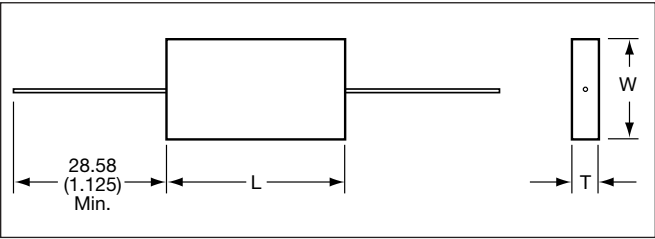
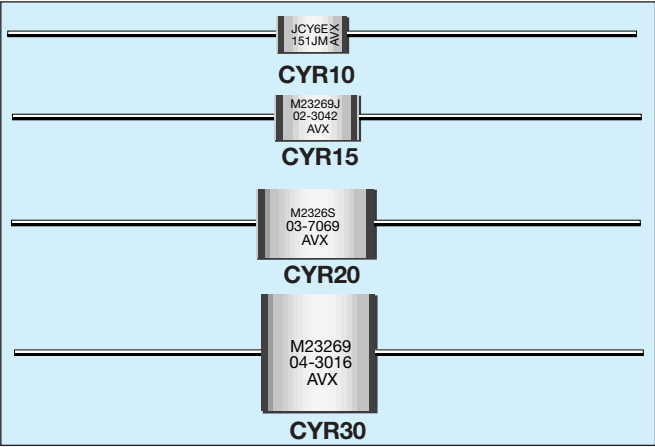

DIMENSIONS: millimeters (inches)

Case Size	L	W	T	Lead Dia. +0.1(+0.004) -0.03(±0.001)
CYR10	8.74 ± 1.19 (0.344 ± 0.047)	4.37 ± .79 (0.172 ± 0.031)	1.98 ± .79 (0.078 ± 0.031)	.51 (0.020)
CYR15	11.91 ± 1.19 (0.469 ± 0.047)	6.76 ± .79 (0.266 ± 0.031)	2.77 ± 1.19 (0.109 ± 0.047)	.51 (0.020)
CYR20	18.64 ± 1.57 (0.734 ± 0.062)	10.72 ± 1.19 (0.422 ± 0.047)	3.58 ± 1.19 (0.141 ± 0.047)	.63 (0.025)
CYR30	19.46 ± 1.57 (0.766 ± 0.062)	19.05 ± 1.98 (0.750 ± 0.078)	3.58 ± 1.19 (0.141 ± 0.047)	.63 (0.025)

Note: Standard leads are solder-coated Dumet.

Military Glass Capacitors

MIL-PRF-23269/01, /02, /03, /04

CYR10, 15, 20, 30



HOW TO ORDER

Military Type Designation: Styles CYR10, CYR15, CYR20, CYR30

Dash Number Option: MIL-PRF-23269/01, 02, 03, 04 (Add Appropriate Dash Number)

M23269

Style

Military Specification
Established Reliability
Glass Capacitor

01

Case Size

01 = CYR10
02 = CYR15
03 = CYR20
04 = CYR30

3

Failure Rate

3 = M level 1%/1000 hrs.
7 = S level .001%/1000 hrs.
(100 volt rating only)

001

Capacitance Code

Capacitance value
coded in accordance
with MIL-PRF-23269 –
(see Part Number section)

MARKING

<p>CYR10</p> <div style="border: 1px solid black; padding: 5px; width: fit-content; margin: auto;"> <p>JCY3A 0R5JM AVX</p> </div>	<p>CYR15-30</p> <div style="border: 1px solid black; padding: 5px; width: fit-content; margin: auto;"> <p>M23269J 02-3057 AVX 03 B</p> </div>
<p>J = JAN Trademark OR5 = Capacitance code – C = Capacitor OR5 = 0.5pF Y = Glass Dielectric J = Capacitance tolerance – 3 = Last digit of year J = ±5%, G = ±2%, F = ±1% A = 4 week lot code M = Failure level AVX = AVX Corporation</p>	<p>M23269 = Military specification established reliability glass capacitor J = JAN Trademark 02 = Case size (CYR15) 3 = Failure rate (M level)</p> <p>057 = Dash Number – (capacitance in pF and capacitance tolerance) AVX = AVX Corporation 03 = Year B = Lot Code</p>

MILITARY PART NUMBER IDENTIFICATION

Cap. Value (pF)	Part Number* Capacitance Tolerance		
CYR10 M23269/01-			
500 Volts**	±.25pF	±.5pF	±5%
.5	* 001	—	—
1.0	002	—	—
1.5	003	—	—
2.2	004	* 005	—
2.7	006	—	—
3.0	007	008	—
3.3	009	—	—
3.6	010	011	—
3.9	012	—	—
4.3	013	014	—
4.7	015	—	—
5.1	016	—	—
5.6	017	—	* 018
6.2	019	—	020
6.8	021	—	022
7.5	023	—	024
8.2	025	—	026
9.1	027	—	028
10	029	—	030
11	031	—	032
12	033	—	034
	±1%	±2%	±5%
13	—	* 035	* 036
15	—	037	038
16	—	039	040
18	—	041	042
20	—	043	044
22	—	045	046
24	—	047	048
27	* 049	050	051
30	052	053	054
33	055	056	057
36	058	059	060
39	061	062	063
43	064	065	066
47	067	068	069
51	070	071	072
56	073	074	075
62	076	077	078

* Add first digit to indicate failure rate.
** S LEVEL = 100V rating for all values.

Cap. Value (pF)	Part Number* Capacitance Tolerance		
CYR10 M23269/01- (cont'd.)			
500 Volts**	±1%	±2%	±5%
68	* 079	* 080	* 081
75	082	083	084
82	085	086	087
91	088	089	090
100	091	092	093
110	094	095	096
120	097	098	099
130	100	101	102
150	103	104	105
160	106	107	108
180	109	110	111
200	112	113	114
300 Volts**	±1%	±2%	±5%
220	115	116	117
240	118	119	120
270	121	122	123
300	124	125	126
CYR15 M23269/02-			
500 Volts**	±1%	±2%	±5%
220	* 001	* 002	* 003
240	004	005	006
270	007	008	009
300	010	011	012
330	013	014	015
360	016	017	018
390	019	020	021
430	022	023	024
470	025	026	027
510	028	029	030
300 Volts**	±1%	±2%	±5%
560	031	032	033
620	034	035	036
680	037	038	039
750	040	041	042
820	043	044	045
910	046	047	048
1,000	049	050	051
1,100	052	053	054
1,200	055	056	057

* Add first digit to indicate failure rate.
** S LEVEL = 100V rating for all values.

Cap. Value (pF)	Part Number* Capacitance Tolerance		
CYR20 M23269/03-			
500 Volts**	±1%	±2%	±5%
560	* 001	* 002	* 003
620	004	005	006
680	007	008	009
750	010	011	012
820	013	014	015
910	016	017	018
1,000	019	020	021
1,100	022	023	024
1,200	025	026	027
1,300	028	029	030
1,500	031	032	033
1,600	034	035	036
1,800	037	038	039
2,000	040	041	042
2,200	043	044	045
2,400	046	047	048
2,700	049	050	051
3,000	052	053	054
3,300	055	056	057
300 Volts**	±1%	±2%	±5%
3,600	3058	3059	3060
3,900	3061	3062	3063
4,300	3064	3065	3066
4,700	3067	3068	3069
5,100	3070	3071	3072
CYR30 M23269/04-			
500 Volts**	±1%	±2%	±5%
3,600	* 001	* 002	* 003
3,900	004	005	006
4,300	007	008	009
4,700	010	011	012
5,100	013	014	015
5,600	016	017	018
6,200	019	020	021
300 Volts**	±1%	±2%	±5%
6,800	3022	3023	3024
7,500	3025	3026	3027
8,200	3028	3029	3030
9,100	3031	3032	3033
10,000	3034	3035	3036

* Add first digit to indicate failure rate.
** S LEVEL = 100V rating for all values.



Military Glass-K Capacitors



MIL-PRF-11015/25 CK31, 32

APPLICATIONS

These miniature multilayer ceramic capacitors, style CK31 and CK32, meet or exceed all requirements of MIL-PRF-11015/25. High volumetric efficiency and reliable performance result from the special GLASS-K dielectric, which is fused into a compact monolithic structure. Available in three different stability characteristics, these capacitors are suitable for both military and commercial applications in miniature circuitry.

PERFORMANCE CHARACTERISTICS

Tolerance: $\pm 20\%$ and $\pm 10\%$ in characteristics "U" and "V", and $\pm 10\%$ and $\pm 5\%$ in characteristic "T".

Stability Characteristics: Available as follows:

- BT-TC: +2, -10%; TVC: +2, -10%
- BU-TC: +2, -15%; TVC: +2, -15%
- BV-TC: +20, -45%; TVC: +20, -50%

Dissipation Factor:

- BT: $\leq 1.0\%$
- BU: $\leq 1.5\%$
- BV: $\leq 3.0\%$

Life: Meets or exceeds requirements of MIL-PRF-11015. At 200% of rated voltage, 125°C, the maximum capacitance change for each stability characteristic is as follows:

- BT: $\pm 2\%$
- BU: $\pm 5\%$
- BV: $\pm 20\%$

Insulation Resistance: 100,000 megohms or 1,000 megohm-microfarads, whichever is less.

Voltage/Temperature Rating: Rated voltage is 50 Vdc. The operating temperature range is -55°C to +125°C.

Moisture Resistance: Meets or exceeds requirements of MIL-PRF-11015 and MIL-STD-202, Method 106. The capacitance change is less than 2% for stability characteristics T and U, and less than 5% for characteristic V.

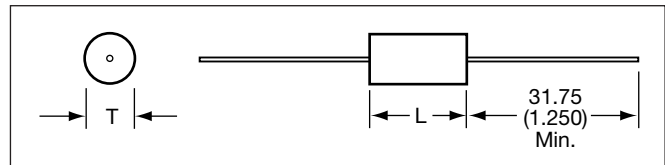
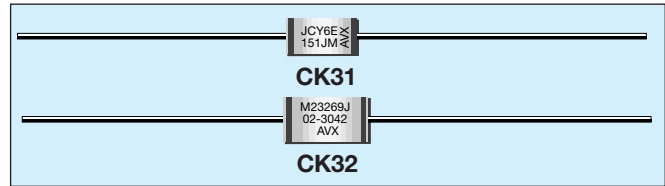

DIMENSIONS:

millimeters (inches)

Case Size	L $\pm .254$ (0.010)	D $\pm .254$ (0.010)	Lead Dia. $+0.1(+0.004)$ $-0.03(\pm 0.001)$	Weight (Grams) (Typ.)
CK31	6.09 (0.240)	2.29 (0.090)	.41 (0.016)	.2
CK32	6.09 (0.240)	3.30 (0.130)	.41 (0.016)	.3

Note: Leads are gold-plated, solderable and weldable Dumet per MIL-STD-1276, Type D.

QUICK SELECTION GUIDE

Capacitance - pF	Style CK	Stability Char.
270 - 10,000	31	BT
12,000 - 20,000	31 32	BU BT
22,000 - 39,000	31 32	BV BU
47,000 - 51,000	31	BV
56,000 - 100,000	32	BV

Military Glass-K Capacitors



MIL-PRF-11015/25

CK31, 32

HOW TO ORDER

Military Type Designation: Styles CK31, CK32

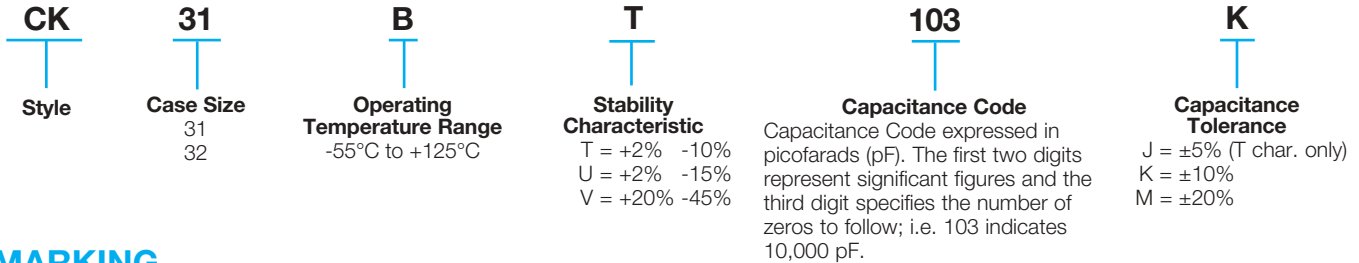

MARKING

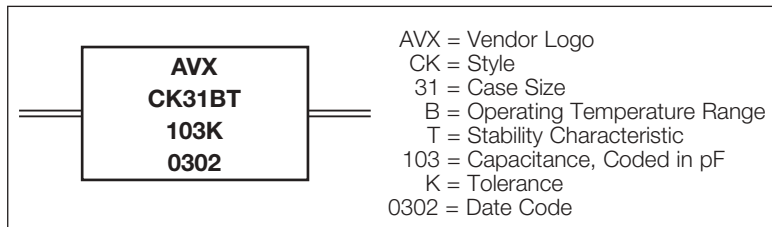

MILITARY PART NUMBER IDENTIFICATION (Standard Values)

Military Type Designation	Capacitance (pF)	Capacitance Tolerance	WVDC
CK31 (BT)			
CK31BT271*	270	J, K	50
CK31BT331_	330	J, K	50
CK31BT391_	390	J, K	50
CK31BT471_	470	J, K	50
CK31BT561_	560	J, K	50
CK31BT681_	680	J, K	50
CK31BT821_	820	J, K	50
CK31BT102_	1,000	J, K	50
CK31BT122_	1,200	J, K	50
CK31BT152_	1,500	J, K	50
CK31BT182_	1,800	J, K	50
CK31BT222_	2,200	J, K	50
CK31BT272_	2,700	J, K	50
CK31BT332_	3,300	J, K	50
CK31BT392_	3,900	J, K	50
CK31BT472_	4,700	J, K	50
CK31BT562_	5,600	J, K	50
CK31BT682_	6,800	J, K	50
CK31BT822_	8,200	J, K	50
CK31BT103_	10,000	J, K	50
CK31 (BU)			
CK31BU123*	12,000	K, M	50
CK31BU153_	15,000	K, M	50
CK31BU183_	18,000	K, M	50
CK31BU203_	20,000	K, M	50
CK31 (BV)			
CK31BV223*	22,000	K, M	50
CK31BV273_	27,000	K, M	50
CK31BV333_	33,000	K, M	50
CK31BV393_	39,000	K, M	50
CK31BV473_	47,000	K, M	50
CK31BV513_	51,000	K, M	50

* Add Capacitance Tolerance Letter
 J = ±5%, K = ±10% or M = ±20%

Military Type Designation	Capacitance (pF)	Capacitance Tolerance	WVDC
CK32 (BT)			
CK32BT123*	12,000	J, M	50
CK32BT153_	15,000	J, M	50
CK32BT183_	18,000	J, M	50
CK32BT203_	20,000	J, M	50
CK32 (BU)			
CK32BU223*	22,000	K, M	50
CK32BU273_	27,000	K, M	50
CK32BU333_	33,000	K, M	50
CK32BU393_	39,000	K, M	50
CK32 (BV)			
CK32BV563*	56,000	K, M	50
CK32BV623_	62,000	K, M	50
CK32BV683_	68,000	K, M	50
CK32BV753_	75,000	K, M	50
CK32BV823_	82,000	K, M	50
CK32BV913_	91,000	K, M	50
CK32BV104_	100,000	K, M	50

* Add Capacitance Tolerance Letter
 J = ±5%, K = ±10% or M = ±20%



Military Glass-K Capacitors



MIL-PRF-39014/21

CKR31, 32

APPLICATIONS

These miniature multilayer ceramic capacitors, style CKR31 and CKR32, are qualified to Established Reliability specification MIL-PRF-39014/21. High volumetric efficiency and reliable performance result from the special GLASS-K dielectric, which is fused into a compact monolithic structure. These capacitors are available in three different stability characteristics.

PERFORMANCE CHARACTERISTICS

Tolerance: $\pm 20\%$ and $\pm 10\%$ in characteristics "U" and "V", and $\pm 10\%$ and $\pm 5\%$ in characteristic "T".

Stability Characteristics: Available as follows:

BT-TC: +2, -10%; TVC: +2, -10%

BU-TC: +2, -15%; TVC: +2, -15%

BV-TC: +20, -45%; TVC: +20, -50%

Dissipation Factor:

BT: $\leq 1.0\%$

BU: $\leq 1.5\%$

BV: $\leq 3.0\%$

Life: Meets or exceeds requirements of MIL-PRF-39014. At 200% of rated voltage, 125°C, at 4,000 hours, the capacitance change for each stability characteristic is as follows:

BT: $\pm 5\%$

BU: $\pm 10\%$

BV: $\pm 20\%$

Insulation Resistance: At 25°C, 100,000 megohms or 1,000 megohm-microfarads. At 125°C, 10,000 megohms or 100 megohm-microfarads.

Voltage/Temperature Rating: Rated voltage is 50 Vdc. The operating temperature range is -55°C to +125°C.

Moisture Resistance: Meets or exceeds requirements of MIL-PRF-39014 and MIL-STD-202, Method 106. The capacitance change is less than 2% for stability characteristics T and U, and less than 5% for characteristic V.

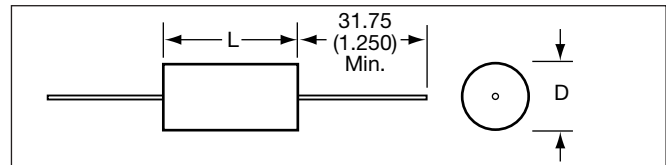
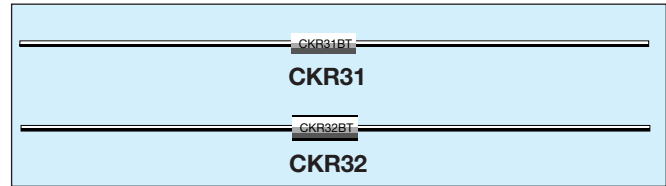

DIMENSIONS:

millimeters (inches)

Case Size	L $\pm .254$ (0.010)	D $\pm .254$ (0.010)	Lead Dia. $+0.1(+0.004)$ $-0.03(\pm 0.001)$	Weight (Grams) (Typ.)
CKR31	6.09 (0.240)	2.29 (0.090)	.41 (0.016)	.2
CKR32	6.09 (0.240)	3.30 (0.130)	.41 (0.016)	.3

Note: Leads are gold-plated, solderable and weldable per MIL-STD-1276, Type D.

QUICK SELECTION GUIDE

Capacitance - pF	Style CKR	Stability Char.
270 - 10,000	31	BT
12,000 - 20,000	31 32	BU BT
22,000 - 39,000	31 32	BV BU
47,000 - 51,000	31	BV
56,000 - 100,000	32	BV

Military Glass-K Capacitors



MIL-PRF-39014/21

CKR31, 32

MARKING

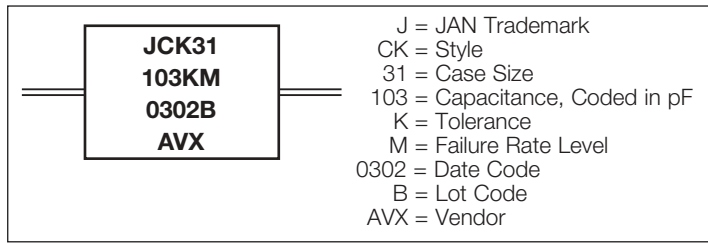

Part Number Explanation

Part numbers are formed by adding a dash number from the part number table to the basic mil spec number – M39014/21 – (add dash number)
 M39014/21 – Example: M39014/21-0040
 CKR31 10,000pF ±10% 50V
 M Failure Rate
 (BT Characteristic)

CROSS REFERENCE

MIL-PRF-39014/21 Style	MIL-PRF-11015/25 Style
CKR31	CK31
CKR32	CK32

M39014/21 (Dash Number) Failure Rate Level (%/1,000 hours) 1.0 (M)	Capacitance Value (pF)	Capacitance Tolerance ± Percent	DC Rated Voltage
CKR31 (BT)			
0001	270	5	50
0002	270	10	50
0003	330	5	50
0004	330	10	50
0005	390	5	50
0006	390	10	50
0007	470	5	50
0008	470	10	50
0009	560	5	50
0010	560	10	50
0011	680	5	50
0012	680	10	50
0013	820	5	50
0014	820	10	50
0015	1,000	5	50
0016	1,000	10	50
0017	1,200	5	50
0018	1,200	10	50
0019	1,500	5	50
0020	1,500	10	50
0021	1,800	5	50
0022	1,800	10	50
0023	2,200	5	50
0024	2,200	10	50
0025	2,700	5	50
0026	2,700	10	50
0027	3,300	5	50
0028	3,300	10	50
0029	3,900	5	50
0030	3,900	10	50
0031	4,700	5	50
0032	4,700	10	50
0033	5,600	5	50
0034	5,600	10	50
0035	6,800	5	50
0036	6,800	10	50
0037	8,200	5	50
0038	8,200	10	50
0039	10,000	5	50
0040	10,000	10	50
CKR31 (BU)			
0041	12,000	10	50
0042	12,000	20	50
0043	15,000	10	50
0044	15,000	20	50
0045	18,000	10	50
0046	18,000	20	50
0047	20,000	10	50
0048	20,000	20	50

M39014/21 (Dash Number) Failure Rate Level (%/1,000 hours) 1.0 (M)	Capacitance Value (pF)	Capacitance Tolerance ± Percent	DC Rated Voltage
CKR31 (BV)			
0049	22,000	10	50
0050	22,000	20	50
0051	27,000	10	50
0052	27,000	20	50
0053	33,000	10	50
0054	33,000	20	50
0055	39,000	10	50
0056	39,000	20	50
0057	47,000	10	50
0058	47,000	20	50
0059	51,000	10	50
0060	51,000	20	50
CKR32 (BT)			
0061	12,000	5	50
0062	12,000	10	50
0063	15,000	5	50
0064	15,000	10	50
0065	18,000	5	50
0066	18,000	10	50
0067	20,000	5	50
0068	20,000	10	50
CKR32 (BU)			
0069	22,000	10	50
0070	22,000	20	50
0071	27,000	10	50
0072	27,000	20	50
0073	33,000	10	50
0074	33,000	20	50
0075	39,000	10	50
0076	39,000	20	50
CKR32 (BV)			
0077	56,000	10	50
0078	56,000	20	50
0079	62,000	10	50
0080	62,000	20	50
0081	68,000	10	50
0082	68,000	20	50
0083	75,000	10	50
0084	75,000	20	50
0085	82,000	10	50
0086	82,000	20	50
0087	91,000	10	50
0088	91,000	20	50
0089	100,000	10	50
0090	100,000	20	50



Military Surface Mount and Microwave Capacitors



MIL-PRF-55681

M, P, R AND S FAILURE RATE LEVEL

50V, 100V (BP and BX)

Style CDR01, CDR02, CDR03, CDR04, CDR05, CDR06, CDR31, CDR32, CDR33, CDR34, CDR35

Slash Sheets

/01, /02, /03, /07, /08, /09, /10, /11

M, P, R AND S FAILURE RATE LEVEL

50V, 100V, 200V, 300V, 500V (BP, BG)

Style CDR11, CDR12, CDR13, CDR14

Slash Sheet

/04

End Terminations

- M = Palladium/Silver
- N = Silver, Nickel, Gold
- S = Solder Coated
- U = Base Metallization, Barrier Metal, Solder Coated
- W = Base Metallization, Barrier Metal, Tin/Lead Alloy
- Y = Base Metallization, Barrier Metal, Tin (100%)

AVX military chip ceramic capacitors offer a wide range of approvals to MIL-PRF-55681. These include standard chip sizes to english (CDR01-CDR06) and metric (CDR31-CDR35) units as well as microwave chip capacitor (CDR11-CDR14).

AVX also offers the engineering support necessary for reliable handling of ceramic chip capacitors. Contact AVX for additional information on attachment of ceramic chip capacitors.

MIL-PRF-55681/CDR31 THRU CDR35

millimeters (inches)

Per MIL-PRF-55681	AVX Style	Length (L)	Width (W)	Thickness (T)		D		Termination Band (t)	
				Max.	Min.	Max.	Min.	Max.	Min.
CDR31	0805	2.00 (0.079)	1.25 (0.049)	1.3 (0.051)	.50 (0.020)	—	.70 (0.028)	.30 (0.012)	.30 (0.012)
CDR32	1206	3.20 (0.126)	1.60 (0.063)	1.3 (0.051)	—	—	.70 (0.028)	.30 (0.012)	.30 (0.012)
CDR33	1210	3.20 (0.126)	2.50 (0.098)	1.5 (0.059)	—	—	.70 (0.028)	.30 (0.012)	.30 (0.012)
CDR34	1812	4.50 (0.177)	3.20 (0.126)	1.5 (0.059)	—	—	.70 (0.028)	.30 (0.012)	.30 (0.012)
CDR35	1825	4.50 (0.177)	6.40 (0.252)	1.5 (0.059)	—	—	.70 (0.028)	.30 (0.012)	.30 (0.012)

MIL-PRF-55681/CDR01 THRU CDR06

millimeters (inches)

Per MIL-PRF-55681	AVX Style	Length (L)	Width (W)	Thickness (T)		D		Termination Band (t)	
				Max.	Min.	Max.	Min.	Max.	Min.
CDR01	0805	2.03 ± .381 (0.080 ± 0.015)	1.27 ± .381 (0.050 ± 0.015)	1.40 (0.055)	.508 (0.020)	—	.762 (0.030)	—	.254 (0.010)
CDR02	1805	4.57 ± .381 (0.180 ± 0.015)	1.27 ± .381 (0.050 ± 0.015)	1.40 (0.055)	.508 (0.020)	—	—	.762 (0.030)	.254 (0.010)
CDR03	1808	4.57 ± .381 (0.180 ± 0.015)	2.03 ± .457 (0.080 ± 0.018)	2.03 (0.080)	.508 (0.020)	—	—	.762 (0.030)	.254 (0.010)
CDR04	1812	4.57 ± .381 (0.180 ± 0.015)	2.03 ± .381 (0.125 ± 0.015)	2.03 (0.080)	.508 (0.020)	—	—	.762 (0.030)	.254 (0.010)
CDR05	1825	4.57 + .508 - .381 (0.180 + 0.020 - 0.015)	6.35 + .508 - .381 (0.250 + 0.020 - 0.015)	2.03 (0.080)	.508 (0.020)	—	—	.762 (0.030)	.254 (0.010)
CDR06	2225	5.71 ± .508 (0.225 ± 0.020)	6.35 ± .508 (0.250 ± 0.020)	2.03 (0.080)	.508 (0.020)	—	—	.762 (0.030)	.254 (0.010)

MIL-PRF-55681E

millimeters (inches)

Per MIL-PRF-55681	AVX Style	Length (L)	Width (W)	Thickness (T)		Termination Band (TB)	
				Max.	Min.	Max.	Min.
CDR11	AQ11	1.40 ± .381 (0.055 ± 0.015)	1.40 ± .381 (0.055 ± 0.015)	1.45 (0.057)	.508 (0.020)	.508 (0.020)	.127 (0.005)
CDR12	AQ12	1.40 ± .635 (0.055 ± 0.025)	1.40 ± .381 (0.055 ± 0.015)	1.45 (0.057)	.508 (0.020)	.508 (0.020)	.127 (0.005)
CDR13	AQ13	2.79 ± .508 (0.110 ± 0.020)	2.79 ± .508 (0.110 ± 0.020)	2.59 (0.102)	.762 (0.030)	.635 (0.025)	.127 (0.005)
CDR14	AQ14	2.79 + .889 - .508 (0.110 + 0.035 - 0.020)	2.79 ± .508 (0.110 ± 0.020)	2.59 (0.102)	.762 (0.020)	.635 (0.025)	.127 (0.005)





Military Surface Mount and Microwave Capacitors

MIL-PRF-55681/01, /02, /03

HOW TO ORDER

Military Type Designation: Styles CDR01, CDR02, CDR03, CDR04, CDR05, CDR06

Dash Number Option: MIL-PRF-55681 (Appropriate Dash Number)

CDR01

MIL Style

BP

Voltage Temperature Limits

101

Capacitance Code

B

Rated Voltage

K

Capacitance Tolerance

S

Termination Finish

M

Failure Rate

MIL Style: CDR01, CDR02, CDR03, CDR04, CDR05, CDR06

Voltage Temperature Limits:

BP = 0 ± 30 ppm/°C without voltage; 0 ± 30 ppm/°C with rated voltage from -55°C to +125°C

BX = $\pm 15\%$ without voltage; +15, -25% with rated voltage from -55°C to +125°C

Capacitance:

Two digit figures followed by multiplier (number of zeros to be added) e.g., 101 = 100 pF

Rated Voltage: A = 50V, B = 100V

Capacitance Tolerance: J = $\pm 5\%$, K = $\pm 10\%$, M = $\pm 20\%$

Termination Finish:

M = Palladium/Silver

U = Base Metallization/Barrier Metal/Solder Coated*

N = Silver, Nickel, Gold

S = Solder Coated

W = Base Metallization/Barrier Metal/Tinned (Tin or Tin/Lead Alloy)

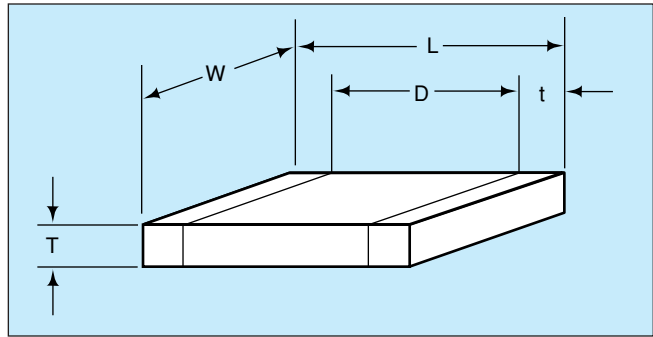

Failure Rate Level: M = 1.0%, P = .1%, R = .01%, S = .001%

Packaging: Bulk is standard packaging. Tape and reel per RS481 is available upon request.

*Solder shall have a melting point of 200°C or less.

AVX/MIL-PRF-55681/CDR01 THRU CDR06*

millimeters (inches)

Per MIL-PRF-55681	AVX Style	Length (L)	Width (W)	Thickness (T)		D		Termination Band (t)	
				Max.	Min.	Max.	Min.	Max.	Min.
CDR01	0805	2.03 ± .381 (0.080 ± 0.015)	1.27 ± .381 (0.050 ± 0.015)	1.40 (0.055)	.508 (0.020)	—	.762 (0.030)	—	.254 (0.010)
CDR02	1805	4.57 ± .381 (0.180 ± 0.015)	1.27 ± .381 (0.050 ± 0.015)	1.40 (0.055)	.508 (0.020)	—	—	.762 (0.030)	.254 (0.010)
CDR03	1808	4.57 ± .381 (0.180 ± 0.015)	2.03 ± .457 (0.080 ± 0.018)	2.03 (0.080)	.508 (0.020)	—	—	.762 (0.030)	.254 (0.010)
CDR04	1812	4.57 ± .381 (0.180 ± 0.015)	2.03 ± .381 (0.125 ± 0.015)	2.03 (0.080)	.508 (0.020)	—	—	.762 (0.030)	.254 (0.010)
CDR05	1825	4.57 ± .508 - .381 (0.180 ± 0.020 - 0.015)	6.35 ± .508 - .381 (0.250 ± 0.020 - 0.015)	2.03 (0.080)	.508 (0.020)	—	—	.762 (0.030)	.254 (0.010)
CDR06	2225	5.71 ± .508 (0.225 ± 0.020)	6.35 ± .508 (0.250 ± 0.020)	2.03 (0.080)	.508 (0.020)	—	—	.762 (0.030)	.254 (0.010)

*For CDR11, 12, 13, and 14 see AVX Microwave Chip Capacitor Catalog



Military Surface Mount and Microwave Capacitors



MIL-PRF-55681/01, /02, /03

CDR01 thru CDR06 to MIL-PRF-55681

Military Type Designation	Capacitance in pF	Capacitance tolerance	Rated temperature and voltage-temperature limits	WVDC
AVX Style 0805/CDR01				
CDR01BP100B---	10	J,K	BP	100
CDR01BP120B---	12	J	BP	100
CDR01BP150B---	15	J,K	BP	100
CDR01BP180B---	18	J	BP	100
CDR01BP220B---	22	J,K	BP	100
CDR01BP270B---	27	J	BP	100
CDR01BP330B---	33	J,K	BP	100
CDR01BP390B---	39	J	BP	100
CDR01BP470B---	47	J,K	BP	100
CDR01BP560B---	56	J	BP	100
CDR01BP680B---	68	J,K	BP	100
CDR01BP820B---	82	J	BP	100
CDR01BP101B---	100	J,K	BP	100
CDR01B--121B---	120	J,K	BP,BX	100
CDR01B--151B---	150	J,K	BP,BX	100
CDR01B--181B---	180	J,K	BP,BX	100
CDR01BX221B---	220	K,M	BX	100
CDR01BX271B---	270	K	BX	100
CDR01BX331B---	330	K,M	BX	100
CDR01BX391B---	390	K	BX	100
CDR01BX471B---	470	K,M	BX	100
CDR01BX561B---	560	K	BX	100
CDR01BX681B---	680	K,M	BX	100
CDR01BX821B---	820	K	BX	100
CDR01BX102B---	1,000	K,M	BX	100
CDR01BX122B---	1,200	K	BX	100
CDR01BX152B---	1,500	K,M	BX	100
CDR01BX182B---	1,800	K	BX	100
CDR01BX222B---	2,200	K,M	BX	100
CDR01BX272B---	2,700	K	BX	100
CDR01BX332B---	3,300	K,M	BX	100
CDR01BX392A---	3,900	K	BX	50
CDR01BX472A---	4,700	K,M	BX	50
AVX Style 1805/CDR02				
CDR02BP221B---	220	J,K	BP	100
CDR02BP271B---	270	J	BP	100
CDR02BX392B---	3,900	K	BX	100
CDR02BX472B---	4,700	K,M	BX	100
CDR02BX562B---	5,600	K	BX	100
CDR02BX682B---	6,800	K,M	BX	100
CDR02BX822B---	8,200	K	BX	100
CDR02BX103B---	10,000	K,M	BX	100
CDR02BX123A---	12,000	K	BX	50
CDR02BX153A---	15,000	K,M	BX	50
CDR02BX183A---	18,000	K	BX	50
CDR02BX223A---	22,000	K,M	BX	50

- Add appropriate failure rate
- Add appropriate termination finish
- Capacitance Tolerance

Military Type Designation	Capacitance in pF	Capacitance tolerance	Rated temperature and voltage-temperature limits	WVDC
AVX Style 1808/CDR03				
CDR03BP331B---	330	J,K	BP	100
CDR03BP391B---	390	J	BP	100
CDR03BP471B---	470	J,K	BP	100
CDR03BP561B---	560	J	BP	100
CDR03BP681B---	680	J,K	BP	100
CDR03BP821B---	820	J	BP	100
CDR03BP102B---	1,000	J,K	BP	100
CDR03BX123B---	12,000	K	BX	100
CDR03BX153B---	15,000	K,M	BX	100
CDR03BX183B---	18,000	K	BX	100
CDR03BX223B---	22,000	K,M	BX	100
CDR03BX273B---	27,000	K	BX	100
CDR03BX333B---	33,000	K,M	BX	100
CDR03BX393A---	39,000	K	BX	50
CDR03BX473A---	47,000	K,M	BX	50
CDR03BX563A---	56,000	K	BX	50
CDR03BX683A---	68,000	K,M	BX	50
AVX Style 1812/CDR04				
CDR04BP122B---	1,200	J	BP	100
CDR04BP152B---	1,500	J,K	BP	100
CDR04BP182B---	1,800	J	BP	100
CDR04BP222B---	2,200	J,K	BP	100
CDR04BP272B---	2,700	J	BP	100
CDR04BP332B---	3,300	J,K	BP	100
CDR04BX393B---	39,000	K	BX	100
CDR04BX473B---	47,000	K,M	BX	100
CDR04BX563B---	56,000	K	BX	100
CDR04BX823A---	82,000	K	BX	50
CDR04BX104A---	100,000	K,M	BX	50
CDR04BX124A---	120,000	K	BX	50
CDR04BX154A---	150,000	K,M	BX	50
CDR04BX184A---	180,000	K	BX	50
AVX Style 1825/CDR05				
CDR05BP392B---	3,900	J,K	BP	100
CDR05BP472B---	4,700	J,K	BP	100
CDR05BP562B---	5,600	J,K	BP	100
CDR05BX683B---	68,000	K,M	BX	100
CDR05BX823B---	82,000	K	BX	100
CDR05BX104B---	100,000	K,M	BX	100
CDR05BX124B---	120,000	K	BX	100
CDR05BX154B---	150,000	K,M	BX	100
CDR05BX224A---	220,000	K,M	BX	50
CDR05BX274A---	270,000	K	BX	50
CDR05BX334A---	330,000	K,M	BX	50
AVX Style 2225/CDR06				
CDR06BP682B---	6,800	J,K	BP	100
CDR06BP822B---	8,200	J,K	BP	100
CDR06BP103B---	10,000	J,K	BP	100
CDR06BX394A---	390,000	K	BX	50
CDR06BX474A---	470,000	K,M	BX	50

- Add appropriate failure rate
- Add appropriate termination finish
- Capacitance Tolerance



Military Surface Mount and Microwave Capacitors

MIL-PRF-55681/07, /08, /09, /10, /11

HOW TO ORDER

Military Type Designation: Styles CDR31, CDR32, CDR33, CDR34, CDR35
Dash Number Option: MIL-PRF-55681 (Appropriate Dash Number)

CDR31

MIL Style

BP

Voltage Temperature Limits

101

Capacitance Code

B

Rated Voltage

K

Capacitance Tolerance

S

Termination Finish

M

Failure Rate

MIL Style: CDR31, CDR32, CDR33, CDR34, CDR35

Voltage Temperature Limits:

BP = 0 ± 30 ppm/°C without voltage; 0 ± 30 ppm/°C with rated voltage from -55°C to +125°C

BX = $\pm 15\%$ without voltage; +15, -25% with rated voltage from -55°C to +125°C

Capacitance:

Two digit figures followed by multiplier (number of zeros to be added) e.g., 101 = 100 pF

Rated Voltage: A = 50V, B = 100V

Capacitance Tolerance: C = $\pm 25\%$ pF, D = $\pm 5\%$ pF,
 F = $\pm 1\%$ J = $\pm 5\%$,
 K = $\pm 10\%$, M = $\pm 20\%$

Termination Finish:

M = Palladium/Silver U = Base Metallization/Barrier Metal/Solder Coated*
 N = Silver, Nickel, Gold
 S = Solder Coated W = Base Metallization/Barrier Metal/Tinned (Tin or Tin/Lead Alloy)

*Solder shall have a melting point of 200°C or less.

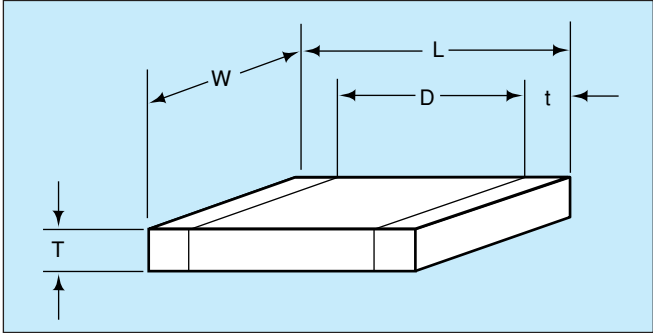

Failure Rate Level: M = 1.0%, P = .1%,
 R = .01%, S = .001%

Packaging: Bulk is standard packaging. Tape and reel per RS481 is available upon request.

Military Surface Mount and Microwave Capacitors



MIL-PRF-55681/07, /08, /09, /10, /11

CDR31 to MIL-PRF-55681/07

Military Type Designation 1/	Capacitance in pF	Capacitance tolerance	Rated temperature and voltage-temperature limits	WVDC
AVX Style 0805/CDR31 (BP)				
CDR31BP1R0B---	1.0	C	BP	100
CDR31BP1R1B---	1.1	C	BP	100
CDR31BP1R2B---	1.2	C	BP	100
CDR31BP1R3B---	1.3	C	BP	100
CDR31BP1R5B---	1.5	C	BP	100
CDR31BP1R6B---	1.6	C	BP	100
CDR31BP1R8B---	1.8	C	BP	100
CDR31BP2R0B---	2.0	C	BP	100
CDR31BP2R2B---	2.2	C	BP	100
CDR31BP2R4B---	2.4	C	BP	100
CDR31BP2R7B---	2.7	C,D	BP	100
CDR31BP3R0B---	3.0	C,D	BP	100
CDR31BP3R3B---	3.3	C,D	BP	100
CDR31BP3R6B---	3.6	C,D	BP	100
CDR31BP3R9B---	3.9	C,D	BP	100
CDR31BP4R3B---	4.3	C,D	BP	100
CDR31BP4R7B---	4.7	C,D	BP	100
CDR31BP5R1B---	5.1	C,D	BP	100
CDR31BP5R6B---	5.6	C,D	BP	100
CDR31BP6R2B---	6.2	C,D	BP	100
CDR31BP6R8B---	6.8	C,D	BP	100
CDR31BP7R5B---	7.5	C,D	BP	100
CDR31BP8R2B---	8.2	C,D	BP	100
CDR31BP9R1B---	9.1	C,D	BP	100
CDR31BP100B---	10	J,K	BP	100
CDR31BP110B---	11	J,K	BP	100
CDR31BP120B---	12	J,K	BP	100
CDR31BP130B---	13	J,K	BP	100
CDR31BP150B---	15	J,K	BP	100
CDR31BP160B---	16	J,K	BP	100
CDR31BP180B---	18	J,K	BP	100
CDR31BP200B---	20	J,K	BP	100
CDR31BP220B---	22	J,K	BP	100
CDR31BP240B---	24	J,K	BP	100
CDR31BP270B---	27	F,J,K	BP	100
CDR31BP300B---	30	F,J,K	BP	100
CDR31BP330B---	33	F,J,K	BP	100
CDR31BP360B---	36	F,J,K	BP	100
CDR31BP390B---	39	F,J,K	BP	100
CDR31BP430B---	43	F,J,K	BP	100
CDR31BP470B---	47	F,J,K	BP	100
CDR31BP510B---	51	F,J,K	BP	100
CDR31BP560B---	56	F,J,K	BP	100
CDR31BP620B---	62	F,J,K	BP	100
CDR31BP680B---	68	F,J,K	BP	100
CDR31BP750B---	75	F,J,K	BP	100
CDR31BP820B---	82	F,J,K	BP	100
CDR31BP910B---	91	F,J,K	BP	100

- Add appropriate failure rate
- Add appropriate termination finish
- Capacitance Tolerance

Military Type Designation 1/	Capacitance in pF	Capacitance tolerance	Rated temperature and voltage-temperature limits	WVDC
AVX Style 0805/CDR31 (BP) cont'd				
CDR31BP101B---	100	F,J,K	BP	100
CDR31BP111B---	110	F,J,K	BP	100
CDR31BP121B---	120	F,J,K	BP	100
CDR31BP131B---	130	F,J,K	BP	100
CDR31BP151B---	150	F,J,K	BP	100
CDR31BP161B---	160	F,J,K	BP	100
CDR31BP181B---	180	F,J,K	BP	100
CDR31BP201B---	200	F,J,K	BP	100
CDR31BP221B---	220	F,J,K	BP	100
CDR31BP241B---	240	F,J,K	BP	100
CDR31BP271B---	270	F,J,K	BP	100
CDR31BP301B---	300	F,J,K	BP	100
CDR31BP331B---	330	F,J,K	BP	100
CDR31BP361B---	360	F,J,K	BP	100
CDR31BP391B---	390	F,J,K	BP	100
CDR31BP431B---	430	F,J,K	BP	100
CDR31BP471B---	470	F,J,K	BP	100
CDR31BP511A---	510	F,J,K	BP	50
CDR31BP561A---	560	F,J,K	BP	50
CDR31BP621A---	620	F,J,K	BP	50
CDR31BP681A---	680	F,J,K	BP	50
AVX Style 0805/CDR31 (BX)				
CDR31BX471B---	470	K,M	BX	100
CDR31BX561B---	560	K,M	BX	100
CDR31BX681B---	680	K,M	BX	100
CDR31BX821B---	820	K,M	BX	100
CDR31BX102B---	1,000	K,M	BX	100
CDR31BX122B---	1,200	K,M	BX	100
CDR31BX152B---	1,500	K,M	BX	100
CDR31BX182B---	1,800	K,M	BX	100
CDR31BX222B---	2,200	K,M	BX	100
CDR31BX272B---	2,700	K,M	BX	100
CDR31BX332B---	3,300	K,M	BX	100
CDR31BX392B---	3,900	K,M	BX	100
CDR31BX472B---	4,700	K,M	BX	100
CDR31BX562A---	5,600	K,M	BX	50
CDR31BX682A---	6,800	K,M	BX	50
CDR31BX822A---	8,200	K,M	BX	50
CDR31BX103A---	10,000	K,M	BX	50
CDR31BX123A---	12,000	K,M	BX	50
CDR31BX153A---	15,000	K,M	BX	50
CDR31BX183A---	18,000	K,M	BX	50

- Add appropriate failure rate
- Add appropriate termination finish
- Capacitance Tolerance

1/ The complete part number will include additional symbols to indicate capacitance tolerance, termination and failure rate level.

Military Surface Mount and Microwave Capacitors



MIL-PRF-55681/07, /08, /09, /10, /11

CDR32 to MIL-PRF-55681/08

Military Type Designation 1/	Capacitance in pF	Capacitance tolerance	Rated temperature and voltage-temperature limits	WVDC
AVX Style 1206/CDR32 (BP)				
CDR32BP1R0B---	1.0	C	BP	100
CDR32BP1R1B---	1.1	C	BP	100
CDR32BP1R2B---	1.2	C	BP	100
CDR32BP1R3B---	1.3	C	BP	100
CDR32BP1R5B---	1.5	C	BP	100
CDR32BP1R6B---	1.6	C	BP	100
CDR32BP1R8B---	1.8	C	BP	100
CDR32BP2R0B---	2.0	C	BP	100
CDR32BP2R2B---	2.2	C	BP	100
CDR32BP2R4B---	2.4	C	BP	100
CDR32BP2R7B---	2.7	C,D	BP	100
CDR32BP3R0B---	3.0	C,D	BP	100
CDR32BP3R3B---	3.3	C,D	BP	100
CDR32BP3R6B---	3.6	C,D	BP	100
CDR32BP3R9B---	3.9	C,D	BP	100
CDR32BP4R3B---	4.3	C,D	BP	100
CDR32BP4R7B---	4.7	C,D	BP	100
CDR32BP5R1B---	5.1	C,D	BP	100
CDR32BP5R6B---	5.6	C,D	BP	100
CDR32BP6R2B---	6.2	C,D	BP	100
CDR32BP6R8B---	6.8	C,D	BP	100
CDR32BP7R5B---	7.5	C,D	BP	100
CDR32BP8R2B---	8.2	C,D	BP	100
CDR32BP9R1B---	9.1	C,D	BP	100
CDR32BP100B---	10	J,K	BP	100
CDR32BP110B---	11	J,K	BP	100
CDR32BP120B---	12	J,K	BP	100
CDR32BP130B---	13	J,K	BP	100
CDR32BP150B---	15	J,K	BP	100
CDR32BP160B---	16	J,K	BP	100
CDR32BP180B---	18	J,K	BP	100
CDR32BP200B---	20	J,K	BP	100
CDR32BP220B---	22	J,K	BP	100
CDR32BP240B---	24	J,K	BP	100
CDR32BP270B---	27	F,J,K	BP	100
CDR32BP300B---	30	F,J,K	BP	100
CDR32BP330B---	33	F,J,K	BP	100
CDR32BP360B---	36	F,J,K	BP	100
CDR32BP390B---	39	F,J,K	BP	100
CDR32BP430B---	43	F,J,K	BP	100
CDR32BP470B---	47	F,J,K	BP	100
CDR32BP510B---	51	F,J,K	BP	100
CDR32BP560B---	56	F,J,K	BP	100
CDR32BP620B---	62	F,J,K	BP	100
CDR32BP680B---	68	F,J,K	BP	100
CDR32BP750B---	75	F,J,K	BP	100
CDR32BP820B---	82	F,J,K	BP	100
CDR32BP910B---	91	F,J,K	BP	100

- Add appropriate failure rate
- Add appropriate termination finish
- Capacitance Tolerance

Military Type Designation 1/	Capacitance in pF	Capacitance tolerance	Rated temperature and voltage-temperature limits	WVDC
AVX Style 1206/CDR32 (BP) cont'd				
CDR32BP101B---	100	F,J,K	BP	100
CDR32BP111B---	110	F,J,K	BP	100
CDR32BP121B---	120	F,J,K	BP	100
CDR32BP131B---	130	F,J,K	BP	100
CDR32BP151B---	150	F,J,K	BP	100
CDR32BP161B---	160	F,J,K	BP	100
CDR32BP181B---	180	F,J,K	BP	100
CDR32BP201B---	200	F,J,K	BP	100
CDR32BP221B---	220	F,J,K	BP	100
CDR32BP241B---	240	F,J,K	BP	100
CDR32BP271B---	270	F,J,K	BP	100
CDR32BP301B---	300	F,J,K	BP	100
CDR32BP331B---	330	F,J,K	BP	100
CDR32BP361B---	360	F,J,K	BP	100
CDR32BP391B---	390	F,J,K	BP	100
CDR32BP431B---	430	F,J,K	BP	100
CDR32BP471B---	470	F,J,K	BP	100
CDR32BP511B---	510	F,J,K	BP	100
CDR32BP561B---	560	F,J,K	BP	100
CDR32BP621B---	620	F,J,K	BP	100
CDR32BP681B---	680	F,J,K	BP	100
CDR32BP751B---	750	F,J,K	BP	100
CDR32BP821B---	820	F,J,K	BP	100
CDR32BP911B---	910	F,J,K	BP	100
CDR32BP102B---	1,000	F,J,K	BP	100
CDR32BP112A---	1,100	F,J,K	BP	50
CDR32BP122A---	1,200	F,J,K	BP	50
CDR32BP132A---	1,300	F,J,K	BP	50
CDR32BP152A---	1,500	F,J,K	BP	50
CDR32BP162A---	1,600	F,J,K	BP	50
CDR32BP182A---	1,800	F,J,K	BP	50
CDR32BP202A---	2,000	F,J,K	BP	50
CDR32BP222A---	2,200	F,J,K	BP	50
AVX Style 1206/CDR32 (BX)				
CDR32BX472B---	4,700	K,M	BX	100
CDR32BX562B---	5,600	K,M	BX	100
CDR32BX682B---	6,800	K,M	BX	100
CDR32BX822B---	8,200	K,M	BX	100
CDR32BX103B---	10,000	K,M	BX	100
CDR32BX123B---	12,000	K,M	BX	100
CDR32BX153B---	15,000	K,M	BX	100
CDR32BX183A---	18,000	K,M	BX	50
CDR32BX223A---	22,000	K,M	BX	50
CDR32BX273A---	27,000	K,M	BX	50
CDR32BX333A---	33,000	K,M	BX	50
CDR32BX393A---	39,000	K,M	BX	50

- Add appropriate failure rate
- Add appropriate termination finish
- Capacitance Tolerance

1/ The complete part number will include additional symbols to indicate capacitance tolerance, termination and failure rate level.



Military Surface Mount and Microwave Capacitors



MIL-PRF-55681/07, /08, /09, /10, /11

CDR33/34/35 to MIL-PRF-55681/09/10/11

Military Type Designation 1/	Capacitance in pF	Capacitance tolerance	Rated temperature and voltage-temperature limits	WVDC
AVX Style 1210/CDR33 (BP)				
CDR33BP102B---	1,000	F,J,K	BP	100
CDR33BP112B---	1,100	F,J,K	BP	100
CDR33BP122B---	1,200	F,J,K	BP	100
CDR33BP132B---	1,300	F,J,K	BP	100
CDR33BP152B---	1,500	F,J,K	BP	100
CDR33BP162B---	1,600	F,J,K	BP	100
CDR33BP182B---	1,800	F,J,K	BP	100
CDR33BP202B---	2,000	F,J,K	BP	100
CDR33BP222B---	2,200	F,J,K	BP	100
CDR33BP242A---	2,400	F,J,K	BP	50
CDR33BP272A---	2,700	F,J,K	BP	50
CDR33BP302A---	3,000	F,J,K	BP	50
CDR33BP332A---	3,300	F,J,K	BP	50
AVX Style 1210/CDR33 (BX)				
CDR33BX153B---	15,000	K,M	BX	100
CDR33BX183B---	18,000	K,M	BX	100
CDR33BX223B---	22,000	K,M	BX	100
CDR33BX273B---	27,000	K,M	BX	100
CDR33BX393A---	39,000	K,M	BX	50
CDR33BX473A---	47,000	K,M	BX	50
CDR33BX563A---	56,000	K,M	BX	50
CDR33BX683A---	68,000	K,M	BX	50
CDR33BX823A---	82,000	K,M	BX	50
CDR33BX104A---	100,000	K,M	BX	50
AVX Style 1812/CDR34 (BP)				
CDR34BP222B---	2,200	F,J,K	BP	100
CDR34BP242B---	2,400	F,J,K	BP	100
CDR34BP272B---	2,700	F,J,K	BP	100
CDR34BP302B---	3,000	F,J,K	BP	100
CDR34BP332B---	3,300	F,J,K	BP	100
CDR34BP362B---	3,600	F,J,K	BP	100
CDR34BP392B---	3,900	F,J,K	BP	100
CDR34BP432B---	4,300	F,J,K	BP	100
CDR34BP472B---	4,700	F,J,K	BP	100
CDR34BP512A---	5,100	F,J,K	BP	50
CDR34BP562A---	5,600	F,J,K	BP	50
CDR34BP622A---	6,200	F,J,K	BP	50
CDR34BP682A---	6,800	F,J,K	BP	50
CDR34BP752A---	7,500	F,J,K	BP	50
CDR34BP822A---	8,200	F,J,K	BP	50
CDR34BP912A---	9,100	F,J,K	BP	50
CDR34BP103A---	10,000	F,J,K	BP	50

- Add appropriate failure rate
- Add appropriate termination finish
- Capacitance Tolerance

Military Type Designation 1/	Capacitance in pF	Capacitance tolerance	Rated temperature and voltage-temperature limits	WVDC
AVX Style 1812/CDR34 (BX)				
CDR34BX273B---	27,000	K,M	BX	100
CDR34BX333B---	33,000	K,M	BX	100
CDR34BX393B---	39,000	K,M	BX	100
CDR34BX473B---	47,000	K,M	BX	100
CDR34BX563B---	56,000	K,M	BX	100
CDR34BX104A---	100,000	K,M	BX	50
CDR34BX124A---	120,000	K,M	BX	50
CDR34BX154A---	150,000	K,M	BX	50
CDR34BX184A---	180,000	K,M	BX	50
AVX Style 1825/CDR35 (BP)				
CDR35BP472B---	4,700	F,J,K	BP	100
CDR35BP512B---	5,100	F,J,K	BP	100
CDR35BP562B---	5,600	F,J,K	BP	100
CDR35BP622B---	6,200	F,J,K	BP	100
CDR35BP682B---	6,800	F,J,K	BP	100
CDR35BP752B---	7,500	F,J,K	BP	100
CDR35BP822B---	8,200	F,J,K	BP	100
CDR35BP912B---	9,100	F,J,K	BP	100
CDR35BP103B---	10,000	F,J,K	BP	100
CDR35BP113A---	11,000	F,J,K	BP	50
CDR35BP123A---	12,000	F,J,K	BP	50
CDR35BP133A---	13,000	F,J,K	BP	50
CDR35BP153A---	15,000	F,J,K	BP	50
CDR35BP163A---	16,000	F,J,K	BP	50
CDR35BP183A---	18,000	F,J,K	BP	50
CDR35BP203A---	20,000	F,J,K	BP	50
CDR35BP223A---	22,000	F,J,K	BP	50
AVX Style 1825/CDR35 (BX)				
CDR35BX563B---	56,000	K,M	BX	100
CDR35BX683B---	68,000	K,M	BX	100
CDR35BX823B---	82,000	K,M	BX	100
CDR35BX104B---	100,000	K,M	BX	100
CDR35BX124B---	120,000	K,M	BX	100
CDR35BX154B---	150,000	K,M	BX	100
CDR35BX184A---	180,000	K,M	BX	50
CDR35BX224A---	220,000	K,M	BX	50
CDR35BX274A---	270,000	K,M	BX	50
CDR35BX334A---	330,000	K,M	BX	50
CDR35BX394A---	390,000	K,M	BX	50
CDR35BX474A---	470,000	K,M	BX	50

- Add appropriate failure rate
- Add appropriate termination finish
- Capacitance Tolerance

1/ The complete part number will include additional symbols to indicate capacitance tolerance, termination and failure rate level.

Military Microwave Chip Capacitors



MIL-PRF-55681E/04

MILITARY DESIGNATION PER MIL-PRF-55681E

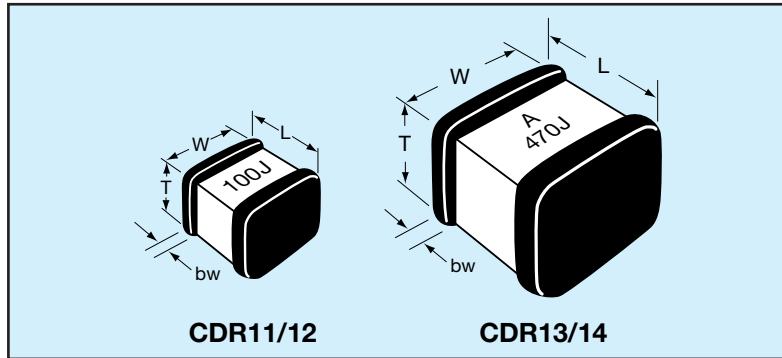

AVX/MIL-PRF-55681E

millimeters (inches)

Per MIL-PRF-55681	AVX Style	Length (L)	Width (W)	Thickness (T)		Termination Band (t)	
				Max.	Min.	Max.	Min.
CDR11	AQ11	1.40 ± .381 (0.055 ± 0.015)	1.40 ± .381 (0.055 ± 0.015)	1.45 (0.057)	.508 (0.020)	.508 (0.020)	.127 (0.005)
CDR12	AQ12	1.40 ± .635 (0.055 ± 0.025)	1.40 ± .381 (0.055 ± 0.015)	1.45 (0.057)	.508 (0.020)	.508 (0.020)	.127 (0.005)
CDR13	AQ13	2.79 ± .508 (0.110 ± 0.020)	2.79 ± .508 (0.110 ± 0.020)	2.59 (0.102)	1.48 (0.030)	.635 (0.025)	.127 (0.005)
CDR14	AQ14	2.79 ± .889 - .508 (0.110 +0.035 -0.020)	2.79 ± .508 (0.110 ± 0.020)	2.59 (0.102)	1.48 (0.030)	.635 (0.025)	.127 (0.005)

HOW TO ORDER

CDR12

MIL Style
CDR11, CDR12,
CDR13, CDR14

BG

Voltage Temperature Limits

BG = +90±20 ppm/°C
with and without
rated voltage from
-55°C to +125°C
BP = 0±30ppm/°C
with and without
rated voltage from
-55°C to +125°C

101

Capacitance

EIA Capacitance Code in pF.
First two digits = significant figures
or "R" for decimal place.
Third digit = number of zeros or
after "R" significant figures.

A

Rated Voltage

A = 50V
B = 100V
C = 200V
D = 300V
E = 500V

K

Capacitance Tolerance

B = ±.1 pF
C = ±.25 pF
D = ±.5 pF
F = ±1%
G = ±2%
J = ±5%
K = ±10%
M = ±20%

U

Termination Finish (Military Designations)

M = Palladium/Silver
(CDR11 & 13 only)
N = Silver, Nickel, Gold
(CDR11 & 13 only)
S = Solder Coated, Final
(CDR12 & 14 only)
U = Base Metalization, Barrier Metal,
Solder Coated
(Solder M.P. 200°C or less)
(CDR12 & 14 only)
W = Base Metalization, Barrier Metal,
Tinned (Tin or Tin/Lead Alloy)
(CDR12 & 14 only)
Y = 100% Tin
Z = Base Metalization, Barrier Metal
(Tin Lead Alloy With 4% Lead Min.)

M

Failure Rate Level
M, P, R & S

PACKAGING

Standard Packaging = Waffle Pack (for T&R packaging see pages 55 and 56)
AQ11/14 maximum quantity per waffle pack 100 pieces.

Military Microwave Chip Capacitors



MIL-PRF-55681E/04

TABLE I: STYLES CDR11 AND CDR12 CAPACITOR CHARACTERISTICS

Type Designation 1/	Capacitance in pF	Capacitance tolerance	Rated temperature and V/Temperature	WVDC	Type Designation 1/	Capacitance in pF	Capacitance tolerance	Rated temperature and V/Temperature	WVDC
CDR1 -B-0R1AB--	0.1	B	BG, BP	50	CDR1 -B-300A---	30	F, G, J, K, M	BG, BP	50
CDR1 -B-0R2AB--	0.2	B	BG, BP	50	CDR1 -B-330A---	33	F, G, J, K, M	BG, BP	50
CDR1 -B-0R3A---	0.3	B, C	BG, BP	50	CDR1 -B-360A---	36	F, G, J, K, M	BG, BP	50
CDR1 -B-0R4A---	0.4	B, C	BG, BP	50	CDR1 -B-390A---	39	F, G, J, K, M	BG, BP	50
CDR1 -B-0R5A---	0.5	B, C, D	BG, BP	50	CDR1 -B-430A---	43	F, G, J, K, M	BG, BP	50
CDR1 -B-0R6A---	0.6	B, C, D	BG, BP	50	CDR1 -B-470A---	47	F, G, J, K, M	BG, BP	50
CDR1 -B-0R7A---	0.7	B, C, D	BG, BP	50	CDR1 -B-510A---	51	F, G, J, K, M	BG, BP	50
CDR1 -B-0R8A---	0.8	B, C, D	BG, BP	50	CDR1 -B-560A---	56	F, G, J, K, M	BG, BP	50
CDR1 -B-0R9A---	0.9	B, C, D	BG, BP	50	CDR1 -B-620A---	62	F, G, J, K, M	BG, BP	50
CDR1 -B-1R0A---	1.0	B, C, D	BG, BP	50	CDR1 -B-680A---	68	F, G, J, K, M	BG, BP	50
CDR1 -B-1R1A---	1.1	B, C, D	BG, BP	50	CDR1 -B-750A---	75	F, G, J, K, M	BG, BP	50
CDR1 -B-1R2A---	1.2	B, C, D	BG, BP	50	CDR1 -B-820A---	82	F, G, J, K, M	BG, BP	50
CDR1 -B-1R3A---	1.3	B, C, D	BG, BP	50	CDR1 -B-910A---	91	F, G, J, K, M	BG, BP	50
CDR1 -B-1R4A---	1.4	B, C, D	BG, BP	50	CDR1 -B-101A---	100	F, G, J, K, M	BG, BP	50
CDR1 -B-1R5A---	1.5	B, C, D	BG, BP	50	CDR1 -B-111A---	110	F, G, J, K, M	BP	50
CDR1 -B-1R6A---	1.6	B, C, D	BG, BP	50	CDR1 -B-121A---	120	F, G, J, K, M	BP	50
CDR1 -B-1R7A---	1.7	B, C, D	BG, BP	50	CDR1 -B-131A---	130	F, G, J, K, M	BP	50
CDR1 -B-1R8A---	1.8	B, C, D	BG, BP	50	CDR1 -B-151A---	150	F, G, J, K, M	BP	50
CDR1 -B-1R9A---	1.9	B, C, D	BG, BP	50	CDR1 -B-161A---	160	F, G, J, K, M	BP	50
CDR1 -B-2R0A---	2.0	B, C, D	BG, BP	50	CDR1 -B-181A---	180	F, G, J, K, M	BP	50
CDR1 -B-2R1A---	2.1	B, C, D	BG, BP	50	CDR1 -B-201A---	200	F, G, J, K, M	BP	50
CDR1 -B-2R2A---	2.2	B, C, D	BG, BP	50	CDR1 -B-221A---	220	F, G, J, K, M	BP	50
CDR1 -B-2R4A---	2.4	B, C, D	BG, BP	50	CDR1 -B-241A---	240	F, G, J, K, M	BP	50
CDR1 -B-2R7A---	2.7	B, C, D	BG, BP	50	CDR1 -B-271A---	270	F, G, J, K, M	BP	50
CDR1 -B-3R0A---	3.0	B, C, D	BG, BP	50	CDR1 -B-301A---	300	F, G, J, K, M	BP	50
CDR1 -B-3R3A---	3.3	B, C, D	BG, BP	50	CDR1 -B-331A---	330	F, G, J, K, M	BP	50
CDR1 -B-3R6A---	3.6	B, C, D	BG, BP	50	CDR1 -B-361A---	360	F, G, J, K, M	BP	50
CDR1 -B-3R9A---	3.9	B, C, D	BG, BP	50	CDR1 -B-391A---	390	F, G, J, K, M	BP	50
CDR1 -B-4R3A---	4.3	B, C, D	BG, BP	50	CDR1 -B-431A---	430	F, G, J, K, M	BP	50
CDR1 -B-4R7A---	4.7	B, C, D	BG, BP	50	CDR1 -B-471A---	470	F, G, J, K, M	BP	50
CDR1 -B-5R1A---	5.1	B, C, D	BG, BP	50	CDR1 -B-511A---	510	F, G, J, K, M	BP	50
CDR1 -B-5R6A---	5.6	B, C, D	BG, BP	50	CDR1 -B-561A---	560	F, G, J, K, M	BP	50
CDR1 -B-6R2A---	6.2	B, C, D	BG, BP	50	CDR1 -B-621A---	620	F, G, J, K, M	BP	50
CDR1 -B-6R8A---	6.8	B, C, J, K, M	BG, BP	50	CDR1 -B-681A---	680	F, G, J, K, M	BP	50
CDR1 -B-7R5A---	7.5	B, C, J, K, M	BG, BP	50	CDR1 -B-751A---	750	F, G, J, K, M	BP	50
CDR1 -B-8R2A---	8.2	B, C, J, K, M	BG, BP	50	CDR1 -B-821A---	820	F, G, J, K, M	BP	50
CDR1 -B-9R1A---	9.1	B, C, J, K, M	BG, BP	50	CDR1 -B-911A---	910	F, G, J, K, M	BP	50
CDR1 -B-100A---	10	F, G, J, K, M	BG, BP	50	CDR1 -B-102A---	1,000	F, G, J, K, M	BP	50
CDR1 -B-110A---	11	F, G, J, K, M	BG, BP	50					
CDR1 -B-120A---	12	F, G, J, K, M	BG, BP	50					
CDR1 -B-130A---	13	F, G, J, K, M	BG, BP	50					
CDR1 -B-150A---	15	F, G, J, K, M	BG, BP	50					
CDR1 -B-160A---	16	F, G, J, K, M	BG, BP	50					
CDR1 -B-180A---	18	F, G, J, K, M	BG, BP	50					
CDR1 -B-200A---	20	F, G, J, K, M	BG, BP	50					
CDR1 -B-220A---	22	F, G, J, K, M	BG, BP	50					
CDR1 -B-240A---	24	F, G, J, K, M	BG, BP	50					
CDR1 -B-270A---	27	F, G, J, K, M	BG, BP	50					

1/Complete type designation will include additional symbols to indicate style, voltage-temperature limits, capacitance tolerance (where applicable), termination finish ("M" or "N" for style CDR11, and "S", "U" or "W" for style CDR12) and failure rate level.

Military Microwave Chip Capacitors



MIL-PRF-55681E/04

TABLE II: STYLES CDR13 AND CDR14 CAPACITOR CHARACTERISTICS

Type Designation 1/	Capacitance in pF	Capacitance tolerance	Rated temperature and V/Temperature	WVDC	Type Designation 1/	Capacitance in pF	Capacitance tolerance	Rated temperature and V/Temperature	WVDC
CDR1 -B-0R1*B--	0.1	B	BG, BP	200/500	CDR1 -B-560*---	56	F, G, J, K, M	BG, BP	200/500
CDR1 -B-0R2*B--	0.2	B	BG, BP	200/500	CDR1 -B-620*---	62	F, G, J, K, M	BG, BP	200/500
CDR1 -B-0R3*---	0.3	B, C	BG, BP	200/500	CDR1 -B-680*---	68	F, G, J, K, M	BG, BP	200/500
CDR1 -B-0R4*---	0.4	B, C	BG, BP	200/500	CDR1 -B-750*---	75	F, G, J, K, M	BG, BP	200/500
CDR1 -B-0R5*---	0.5	B, C, D	BG, BP	200/500	CDR1 -B-820*---	82	F, G, J, K, M	BG, BP	200/500
CDR1 -B-0R6*---	0.6	B, C, D	BG, BP	200/500	CDR1 -B-910*---	91	F, G, J, K, M	BG, BP	200/500
CDR1 -B-0R7*---	0.7	B, C, D	BG, BP	200/500	CDR1 -B-101*---	100	F, G, J, K, M	BG, BP	200/500
CDR1 -B-0R8*---	0.8	B, C, D	BG, BP	200/500	CDR1 -B-111‡---	110	F, G, J, K, M	BG, BP	200/300
CDR1 -B-0R9*---	0.9	B, C, D	BG, BP	200/500	CDR1 -B-121‡---	120	F, G, J, K, M	BG, BP	200/300
CDR1 -B-1R0*---	1.0	B, C, D	BG, BP	200/500	CDR1 -B-131‡---	130	F, G, J, K, M	BG, BP	200/300
CDR1 -B-1R1*---	1.1	B, C, D	BG, BP	200/500	CDR1 -B-151‡---	150	F, G, J, K, M	BG, BP	200/300
CDR1 -B-1R2*---	1.2	B, C, D	BG, BP	200/500	CDR1 -B-161‡---	160	F, G, J, K, M	BG, BP	200/300
CDR1 -B-1R3*---	1.3	B, C, D	BG, BP	200/500	CDR1 -B-181‡---	180	F, G, J, K, M	BG, BP	200/300
CDR1 -B-1R4*---	1.4	B, C, D	BG, BP	200/500	CDR1 -B-201‡---	200	F, G, J, K, M	BG, BP	200/300
CDR1 -B-1R5*---	1.5	B, C, D	BG, BP	200/500	CDR1 -B-221C---	220	F, G, J, K, M	BG, BP	200
CDR1 -B-1R6*---	1.6	B, C, D	BG, BP	200/500	CDR1 -B-241C---	240	F, G, J, K, M	BG, BP	200
CDR1 -B-1R7*---	1.7	B, C, D	BG, BP	200/500	CDR1 -B-271C---	270	F, G, J, K, M	BG, BP	200
CDR1 -B-1R8*---	1.8	B, C, D	BG, BP	200/500	CDR1 -B-301C---	300	F, G, J, K, M	BG, BP	200
CDR1 -B-1R9*---	1.9	B, C, D	BG, BP	200/500	CDR1 -B-331C---	330	F, G, J, K, M	BG, BP	200
CDR1 -B-2R0*---	2.0	B, C, D	BG, BP	200/500	CDR1 -B-361C---	360	F, G, J, K, M	BG, BP	200
CDR1 -B-2R1*---	2.1	B, C, D	BG, BP	200/500	CDR1 -B-391C---	390	F, G, J, K, M	BG, BP	200
CDR1 -B-2R2*---	2.2	B, C, D	BG, BP	200/500	CDR1 -B-431C---	430	F, G, J, K, M	BG, BP	200
CDR1 -B-2R4*---	2.4	B, C, D	BG, BP	200/500	CDR1 -B-471C---	470	F, G, J, K, M	BG, BP	200
CDR1 -B-2R7*---	2.7	B, C, D	BG, BP	200/500	CDR1 -B-511B---	510	F, G, J, K, M	BG, BP	100
CDR1 -B-3R0*---	3.0	B, C, D	BG, BP	200/500	CDR1 -B-561B---	560	F, G, J, K, M	BG, BP	100
CDR1 -B-3R3*---	3.3	B, C, D	BG, BP	200/500	CDR1 -B-621B---	620	F, G, J, K, M	BG, BP	100
CDR1 -B-3R6*---	3.6	B, C, D	BG, BP	200/500	CDR1 -B-681A---	680	F, G, J, K, M	BG, BP	50
CDR1 -B-3R9*---	3.9	B, C, D	BG, BP	200/500	CDR1 -B-751A---	750	F, G, J, K, M	BG, BP	50
CDR1 -B-4R3*---	4.3	B, C, D	BG, BP	200/500	CDR1 -B-821A---	820	F, G, J, K, M	BG, BP	50
CDR1 -B-4R7*---	4.7	B, C, D	BG, BP	200/500	CDR1 -B-911A---	910	F, G, J, K, M	BG, BP	50
CDR1 -B-5R1*---	5.1	B, C, D	BG, BP	200/500	CDR1 -B-102A---	1,000	F, G, J, K, M	BG, BP	50
CDR1 -B-5R6*---	5.6	B, C, D	BG, BP	200/500	CDR1 -B-112A---	1,100	F, G, J, K, M	BP	50
CDR1 -B-6R2*---	6.2	B, C, D	BG, BP	200/500	CDR1 -B-122A---	1,200	F, G, J, K, M	BP	50
CDR1 -B-6R8*---	6.8	B, C, J, K, M	BG, BP	200/500	CDR1 -B-132A---	1,300	F, G, J, K, M	BP	50
CDR1 -B-7R5*---	7.5	B, C, J, K, M	BG, BP	200/500	CDR1 -B-152A---	1,500	F, G, J, K, M	BP	50
CDR1 -B-8R2*---	8.2	B, C, J, K, M	BG, BP	200/500	CDR1 -B-162A---	1,600	F, G, J, K, M	BP	50
CDR1 -B-9R1*---	9.1	B, C, J, K, M	BG, BP	200/500	CDR1 -B-182A---	1,800	F, G, J, K, M	BP	50
CDR1 -B-100*---	10	F, G, J, K, M	BG, BP	200/500	CDR1 -B-202A---	2,000	F, G, J, K, M	BP	50
CDR1 -B-110*---	11	F, G, J, K, M	BG, BP	200/500	CDR1 -B-222A---	2,200	F, G, J, K, M	BP	50
CDR1 -B-120*---	12	F, G, J, K, M	BG, BP	200/500	CDR1 -B-242A---	2,400	F, G, J, K, M	BP	50
CDR1 -B-130*---	13	F, G, J, K, M	BG, BP	200/500	CDR1 -B-272A---	2,700	F, G, J, K, M	BP	50
CDR1 -B-150*---	15	F, G, J, K, M	BG, BP	200/500	CDR1 -B-302A---	3,000	F, G, J, K, M	BP	50
CDR1 -B-160*---	16	F, G, J, K, M	BG, BP	200/500	CDR1 -B-332A---	3,300	F, G, J, K, M	BP	50
CDR1 -B-180*---	18	F, G, J, K, M	BG, BP	200/500	CDR1 -B-362A---	3,600	F, G, J, K, M	BP	50
CDR1 -B-200*---	20	F, G, J, K, M	BG, BP	200/500	CDR1 -B-392A---	3,900	F, G, J, K, M	BP	50
CDR1 -B-220*---	22	F, G, J, K, M	BG, BP	200/500	CDR1 -B-432A---	4,300	F, G, J, K, M	BP	50
CDR1 -B-240*---	24	F, G, J, K, M	BG, BP	200/500	CDR1 -B-472A---	4,700	F, G, J, K, M	BP	50
CDR1 -B-270*---	27	F, G, J, K, M	BG, BP	200/500	CDR1 -B-502A---	5,000	F, G, J, K, M	BP	50
CDR1 -B-300*---	30	F, G, J, K, M	BG, BP	200/500	CDR1 -B-512A---	5,100	F, G, J, K, M	BP	50
CDR1 -B-330*---	33	F, G, J, K, M	BG, BP	200/500					
CDR1 -B-360*---	36	F, G, J, K, M	BG, BP	200/500					
CDR1 -B-390*---	39	F, G, J, K, M	BG, BP	200/500					
CDR1 -B-430*---	43	F, G, J, K, M	BG, BP	200/500					
CDR1 -B-470*---	47	F, G, J, K, M	BG, BP	200/500					
CDR1 -B-510*---	51	F, G, J, K, M	BG, BP	200/500					

1/Complete type designation will include additional symbols to indicate style, voltage-temperature limits, capacitance tolerance (where applicable), termination finish ("M" or "N" for style CDR13, and "S", "U" or "W" for style CDR14) and failure rate level.

*C=200V; E=500V.

‡C=200V; D=300V.



Packaging of Chip Components



Automatic Insertion Packaging

TAPE & REEL QUANTITIES

All tape and reel specifications are in compliance with RS481.

	8mm	12mm	
Embossed or Punched Carrier	CDR33, CDR31, CDR32, CDR01		
Embossed Only	0504, 0907	CDR03, CDR02	CDR04, CDR34, CDR05, CDR35, CDR06
Punched Only	0402, 0603		
Qty. per Reel/ 7" Reel	2,000 or 4,000(1)	3,000	1,000
Qty. per Reel/ 13" Reel	10,000	10,000	4,000

(1) Dependent on chip thickness.

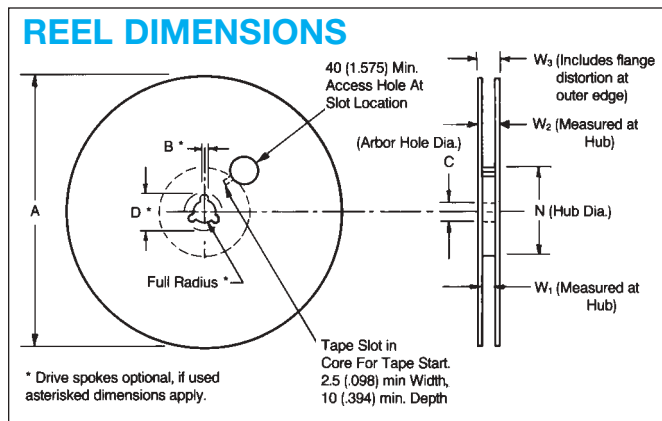

Tape Size ⁽¹⁾	A Max.	B* Min.	C	D* Min.	N Min.	W ₁	W ₂ Max.	W ₃
8mm	330 (12.992)	1.5 (0.059)	13.0±0.20 (0.512±0.008)	20.2 (0.795)	50 (1.969)	8.4 ^{+1.0} _{-0.0} (0.331 ^{+0.060} _{-0.0})	14.4 (0.567)	7.9 Min. (0.311) 10.9 Max. (0.429)
12mm	330 (12.992)	1.5 (0.059)	13.0±0.20 (0.512±0.008)	20.2 (0.795)	50 (1.969)	12.4 ^{+2.0} _{-0.0} (0.488 ^{+0.076} _{-0.0})	18.4 (0.724)	11.9 Min. (0.469) 15.4 Max. (0.607)

Metric dimensions will govern.

English measurements rounded and for reference only.

(1) For tape sizes 16mm and 24mm (used with chip size 3640) consult EIA RS-481 latest revision.

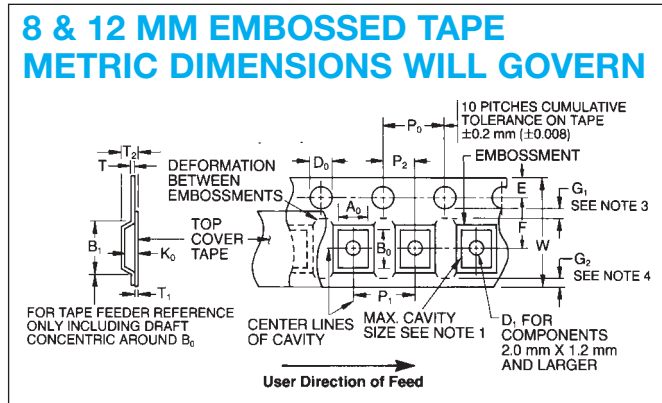

EMBOSSED CARRIER CONFIGURATION 8 & 12 MM TAPE ONLY

VARIABLE DIMENSIONS

Tape Size	B ₁ Max. See Note 6	D ₁ Min. See Note 5	F	P ₁	R Min. See Note 2	T ₂	W	A ₀ B ₀ K ₀
8mm	4.55 (0.179)	1.0 (0.039)	3.5 ± 0.05 (0.138 ± 0.002)	4.0 ± 0.10 (0.157 ± 0.004)	25 (0.984)	2.5 Max. (0.098)	8.0 ^{+0.3} _{-0.1} (0.315 ^{+0.012} _{-0.004})	See Note 1
12mm	8.2 (0.323)	1.5 (0.059)	5.5 ± 0.05 (0.217 ± 0.002)	4.0 ± 0.10 (0.157 ± 0.004)	30 (1.181)	6.5 Max. (0.256)	12.0 ± .30 (0.472 ± 0.012)	See Note 1
8mm 1/2 Pitch	4.55 (0.179)	1.0 (0.039)	3.5 ± 0.05 (0.138 ± 0.002)	2.0 ± 0.10 (0.79 ± 0.004)	25 (0.984)	2.5 Max. (0.098)	8.0 ^{+0.3} _{-0.1} (0.315 ^{+0.012} _{-0.004})	See Note 1
12mm Double Pitch	8.2 (0.323)	1.5 (0.059)	5.5 ± 0.05 (0.217 ± 0.002)	8.0 ± 0.10 (0.315 ± 0.004)	30 (1.181)	6.5 Max. (0.256)	12.0 ± .30 (0.472 ± 0.012)	See Note 1

CONSTANT DIMENSIONS

Tape Size	D ₀	E	P ₀	P ₂	T Max.	T ₁	G ₁	G ₂
8mm and 12mm	8.4 ^{+1.0} _{-0.0} (0.059 ^{+0.004} _{-0.0})	1.75 ± 0.10 (0.069 ± 0.004)	4.0 ± 0.10 (0.157 ± 0.004)	2.0 ± 0.05 (0.079 ± 0.002)	0.600 (0.024)	0.10 (0.004) Max.	0.75 (0.030) Min. See Note 3	0.75 (0.030) Min. See Note 4

NOTES:

- A₀, B₀, and K₀ are determined by the max. dimensions to the ends of the terminals extending from the component body and/or the body dimensions of the component. The clearance between the end of the terminals or body of the component to the sides and depth of the cavity (A₀, B₀, and K₀) must be within 0.05 mm (.002) min. and 0.50 mm (.020) max. The clearance allowed must also prevent rotation of the component within the cavity of not more than 20 degrees (see sketches C & D).
- Tape with components shall pass around radius "R" without damage. The minimum trailer length (Note 2 Fig. 3) may require additional length to provide R min. for 12 mm embossed tape for reels with hub diameters approaching N min. (Table 4).
- G₁ dimension is the flat area from the edge of the sprocket hole to either the outward deformation of the carrier tape between the embossed cavities or to the edge of the cavity whichever is less.
- G₂ dimension is the flat area from the edge of the carrier tape opposite the sprocket holes to either the outward deformation of the carrier tape between the embossed cavity or to the edge of the cavity whichever is less.
- The embossment hole location shall be measured from the sprocket hole controlling the location of the embossment. Dimensions of embossment location and hole location shall be applied independent of each other.
- B₁ dimension is a reference dimension for tape feeder clearance only.

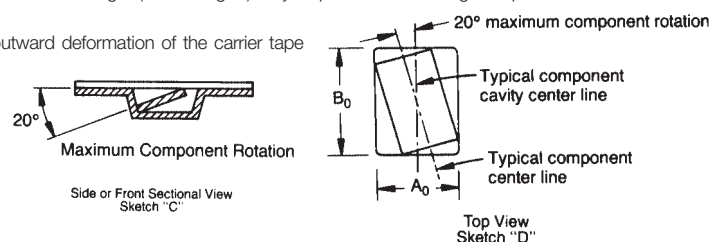

Punched Carrier Configuration



8 & 12 mm Tape Only

CONSTANT DIMENSIONS

Tape Size	D ₀	E	P ₀	P ₂	T ₁	G ₁	G ₂	R MIN.
8mm and 12mm	1.5 ^{+0.1} _{-0.0} (0.059 ^{+0.004} _{-0.000})	1.75 ± 0.10 (0.069 ± 0.004)	4.0 ± 0.10 (0.157 ± 0.004)	2.0 ± 0.05 (0.079 ± 0.002)	0.10 (0.004) Max.	0.75 (0.030) Min.	0.75 (0.030) Min.	25 (0.984) See Note 2

VARIABLE DIMENSIONS

Tape Size	P ₁	F	W	A ₀ B ₀	T
8mm	4.0 ± 0.10 (0.157 ± 0.004)	3.5 ± 0.05 (0.138 ± 0.002)	8.0 ^{+0.3} _{-0.1} (0.315 ^{+0.012} _{-0.004})	See Note 1	See Note 3
12mm	4.0 ± .010 (0.157 ± 0.004)	5.5 ± 0.05 (0.217 ± 0.002)	12.0 ± 0.3 (0.472 ± 0.012)		
8mm 1/2 Pitch	2.0 ± 0.10 (0.079 ± 0.004)	3.5 ± 0.05 (0.138 ± 0.002)	8.0 ^{+0.3} _{-0.1} (0.315 ^{+0.012} _{-0.004})		
12mm Double Pitch	8.0 ± 0.10 (0.315 ± 0.004)	5.5 ± 0.05 (0.217 ± 0.002)	12.0 ± 0.3 (0.472 ± 0.012)		

8 & 12 MM PUNCHED TAPE METRIC DIMENSIONS WILL GOVERN

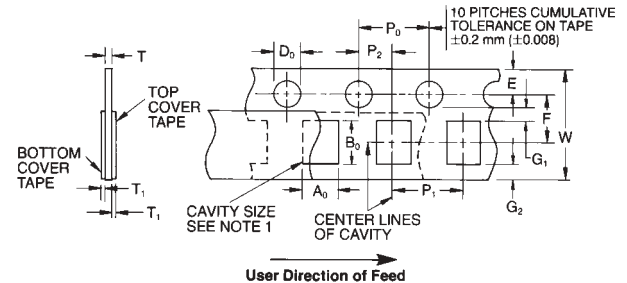

NOTES:

- A₀, B₀, and T are determined by the max. dimensions to the ends of the terminals extending from the component body and/or the body dimensions of the component. The clearance between the ends of the terminals or body of the component to the sides and depth of the cavity (A₀, B₀, and T) must be within 0.05 mm (.002) min. and 0.50 mm (.020) max. The clearance allowed must also prevent rotation of the component within the cavity of not more than 20 degrees (see sketches A & B).
- Tape with components shall pass around radius "R" without damage.
- 1.1 mm (.043) Base Tape and 1.6 mm (.063) Max. for Non-Paper Base Compositions.

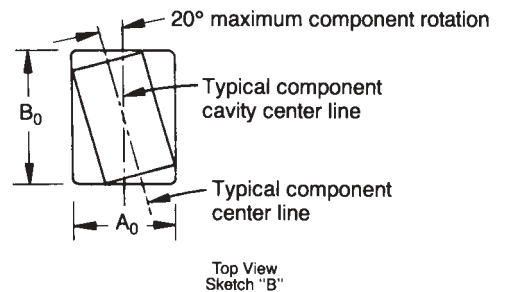
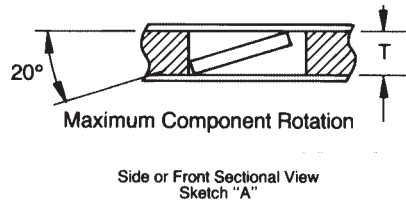

BAR CODE LABELING STANDARD

AVX bar code labeling is available and follows latest version of EIA-556-A.

AUTOMATIC INSERTION PACKAGING TAPE & REEL

All tape and reel specifications are in compliance with EIA 481A. (equivalent to IEC 286 part 3).

- 8mm carrier
- Reeled quantities: Reels of 3,000 per 7" reel or 10,000 pieces per 13" reel 0402 = 5,000 pieces per 7" reel and 20,000 pieces per 13" reel

CARRIER DIMENSIONS: millimeters (inches)

A	B	C	D	E	F
8.0 ± 0.3 (0.315 ± 0.012)	3.5 ± 0.05 (0.138 ± 0.002)	1.75 ± 0.1 (0.069 ± 0.004)	2.0 ± 0.05 (0.079 ± 0.002)	4.0 ± 0.1 (0.157 ± 0.004)	1.5 ^{+0.1} _{-0.0} (0.059 ^{+0.004} _{-0.000})

Note: The nominal dimensions of the component compartment (W, L) are derived from the component size.

REEL DIMENSIONS: millimeters (inches)

A ⁽¹⁾	B	C	D	E	F	G
180 ± 1.0 (7.087 ± 0.039)	1.5 min. (0.059 min.)	13 ± 0.2 (0.512 ± 0.008)	20.2 min. (0.795 min.)	50 min. (1.969 min.)	9.6 ± 1.5 (0.370 ± 0.050)	14.4 max. (0.567 max.)

Metric dimensions will govern.
Inch measurements rounded and for reference only.

(1) 330mm (13 inch) reels are available.

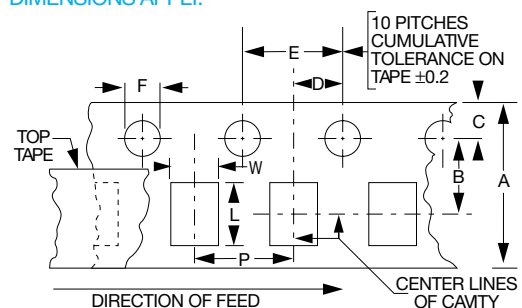
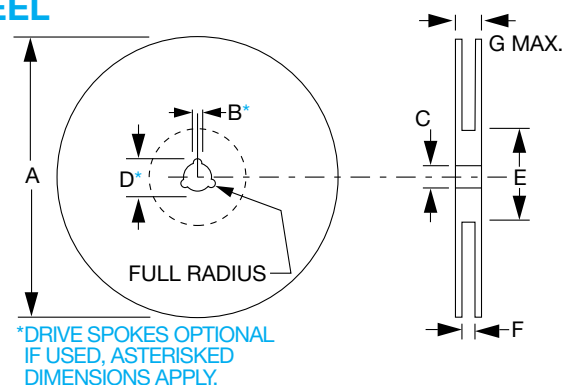

P = 4mm except 0402 where P = 2mm

NOTE: AVX reserves the right to change the information published herein without notice.



MIL-PRF-55365 ESTABLISHED RELIABILITY

A, M, P, R, S, B, C and D Failure Rate Level

All Voltages	6-50 Volts
All Case Sizes	All Case Sizes
Terminations: B, C, K	Terminations: B, C, K
Style CWR09	Style CWR11
Slash Sheet /04	Slash Sheet /08

AVX presently offers the widest range of molded SMT military components in the industry. With two series: the CWR09 and the CWR11, AVX meets the requirements of a majority of military applications.

AVX provides a full range of failure rate levels, termination finishes and packaging options. We also work closely with our customers to develop cost effective Source Control Drawings (SCD) when the tantalum capacitor requirement is not covered by an existing specification.

The following is a partial list of programs which have used AVX Tantalum:

F-22	Harpoon
F-16	Apache
JSOW	Sinegar Radio
Paveway	Tow & Towfott
AMRAM	LAAMPS
Patriot	Hawkeye
Javelin	Sidewinder/AIM-9X
F-18	MSET

BIDDEFORD SURFACE MOUNT MILITARY/AEROSPACE PRODUCT

AVX Tantalum Division at Biddeford is an ISO 9001 registered facility offering a wide range of product to address all Military requirements, being the only manufacturer to offer fully molded versions of all hybrid and EIA standard form factors.

Based on the core qualifications maintained for CWR09 and CWR11 product, new products are now available utilizing the latest advances in tantalum technology, which allow active downsizing and component count reduction, yet which incorporate manufacturing in accordance with MIL-PRF-55365 and reliability options from standard to "C" Weibull grading.

A special facility within the plant enables the production of application specific modules and arrays, providing solutions for specialized requirements.

CWR09

Fully qualified to MIL-PRF-55365, this series represents the most flexible of surface mount form factors, offering eight case sizes to cover the full Capacitance/Voltage range. Parts are suited to hybrid or PCB assembly, while case sizes A to E offer a low profile (0.050" nom) molded chip configuration. Reliability levels from standard to "C" Weibull grading are available, along with ambient and high/low temperature surge options. This series is a molded, interchangeable alternative to CWR06 conformal types, while offering the advantages of molded body/compliant termination construction, polarity, capacitance and JAN brand packaging. Parts are ordered by standard CWR09 part number. The CWR09 series remains the form factor of choice for most military/aerospace tantalum applications due to their low profile and volumetric efficiency.

CWR19/CWR29 Extended Range/ Low ESR (Proposed)

Built to the same form-factor as CWR09, this series offers extended capacitance/voltage ratings (currently available by SCD as the Hi-Rel TAZ series) for ratings from 4-25v. Parts are suited to hybrid or PCB assembly, while case sizes A to E offer a low profile (0.050" nom) molded chip configuration. Reliability levels from standard to "C" Weibull grading are proposed, along with ambient and high/low temperature surge options.

A new case size (V case) has been added to extend capacitance ratings to 470µF; for the large case size (G, H and V case) the CWR29 offers low ESR (to sub-100mΩ levels) for critical power supply designs.

CWR11

Fully qualified to MIL-PRF-55365, this series offers a more limited range of form factors (4 case sizes, A through D) which have the advantage of being designed to EIA standard sizes, using common board layout designs shared with commercial product. Reliability levels from standard to "C" Weibull grading are available, along with ambient and high/low temperature surge options. Parts carry polarity, capacitance and JAN brand marking and are ordered by standard CWR11 part number.

COTS-Plus Series

This series is based on both TAZ (CWR09) and TBJ (CWR11) form factors. Leadership in tantalum technology has enabled the introduction of extended capacitance/voltage ratings for all standard case sizes, giving the designer scope for downsizing existing assemblies and reducing component count. To reduce time to market for the introduction of extended CV ratings into military applications, these parts are supplied in accordance with MIL-PRF-55365, but are not JAN branded. The TAZ ratings are already used extensively in medical/human implantable applications, which prefer a molded, low profile construction and demand high reliability. Applications for TBJ ratings include many real-estate limited aerospace designs. These parts can also be supplied to Source Control Drawings for specific military requirements. A standard reliability level, equivalent to level M/P, is available, together with the option of certified testing to Weibull “B” or “C” grade. Other options include ambient or high/low temperature surge and Low ESR ratings below current MIL-PRF-55365 specification limits. Extended case sizes beyond the CWR standards are also available, especially targeted to high capacitance power supply filtering applications. These allow the conversion of previous through-hole applications to surface mount. The COTS-Plus Series also includes standard range alternatives to CWR09.

This series has been developed in response to the “Commercial Off The Shelf” initiative taken by many military users to enable cost effective procurement of current technologies. By incorporating options for all reliability grades and manufacturing in accordance with MIL-PRF-55365, AVX can supply alternatives for any military requirement.

Low ESR Ratings for Military Applications

Even more so than commercial power supplies, military power supplies require the lowest ESR product (which give maximum ripple handling) with the greatest volumetric efficiency.

The technology that enables AVX to offer the lowest ESR molded tantalum product (in the TPS series) is also available for military applications; again, utilizing the COTS-Plus part numbering system. This allows both standard QPL and extended range/special case size ratings (including V case) with optimized ESR to be specified.

Modules and Special Products

Using standard CWR09, or extended COTS-Plus ratings, capacitor modules offering parallel configurations for high capacitance applications maximizing volumetric efficiency and minimizing real estate are available. These can be supplied in pre-configured packages or custom built for application specific designs. Designed for specialized power filtering applications, these configurations also minimize ESR and self-inductance.

Special Testing Capabilities

- Solderability
- Surge Voltage
- Surge Current
- Thermal Shock
- Bake Out
- X-Ray
- Resistance to Solder Heat
- Special Electrical Requirements (low ESR, tighten DCL)
- Moisture/Humidity
- Temperature Stability
- Life Testing
- Voltage Conditioning
- Resistance to Solvents

Space Level Applications

Space level applications require both high reliability (as specified by Weibull Grading) and assured functionality on board. Historically, Weibull grading only has been used to specify reliability requirements, the drawback to this approach being that on board functionality is not assessed. For many space level applications, the optimum reliability/performance can be specified by combining “B” Weibull with high/low temperature surge option per MIL-PRF-39003. For applications requiring application-specific lot conformance, to address this, AVX have developed a specification that includes function testing by lot. This testing has been developed for high reliability implantable grade medical product. Referenced as HRC 5000, it delineates the minimum process control and environmental test requirements for all tantalum chip capacitors used in implantable life support applications.

100% Reliability testing to the required Weibull Grade is completed, followed by lot function testing.

Per lot function testing includes:

- Simulated reflow, 260°C/30 secs on alumina substrate
- 2x Rework Cycles per above profile
- Preconditioning at 150°C/24 hrs.
- 10x Temp Cycling, -65°C to 150°C
- Accelerated Life, 85°C, 1.3 Rated Volts (Pre-and Post-read & record data used, accept 0 defects post ageing)
- Real Time X-Ray Inspection

Additional periodic testing is maintained, including Temperature Stability, 2000 Hr 125°C Life Test, Moisture Resistance and Solvent Resistance, per MIL-STD-202.

Weibull Grades B and C are typically specified. In practice, Weibull C grade, with additional voltage derating, can be used to give a lower failure rate than Weibull level D at standard rating.

Military Tantalum Capacitors

MIL-PRF-55365/04

CWR09 Series



MARKING

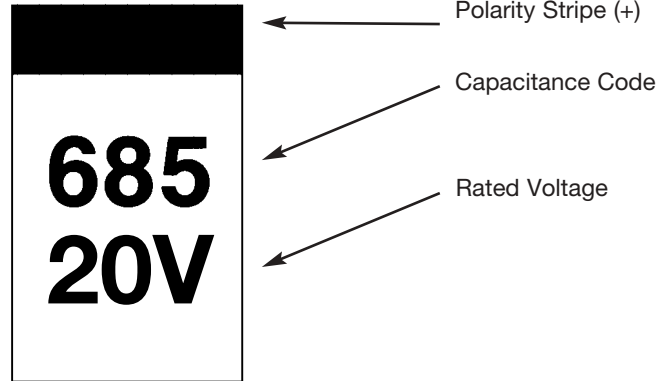

HOW TO ORDER (MIL-PRF-55365/04)

CWR09	F	B	225	K	M	A	\TR
Style	Voltage	Termination Finish	Capacitance Code	Tolerance	Failure Rate	Optional Surge Current	Packaging
	C = 4 D = 6 F = 10 H = 15 J = 20 K = 25 M = 35 N = 50	B = Gold Plated C = Hot Solder Dipped K = Solder Fused		J = ±5% K = ±10% M = ±20%	Exponential: M = 1%/1000 hours P = 0.1%/1000 hours R = 0.01%/1000 hours S = 0.001%/1000 hours Weibull: B = 0.1%/1000 hours C = 0.01%/1000 hours	A = 10 cycles at 25°C B = 10 cycles at -55°C and +85°C	Bulk (Standard if nothing is specified in this position) \TR = 7" Tape & Reel \TR13 = 13" Tape & Reel W = Waffle Pack

NOTES: CWR09 is fully interchangeable with CWR06.
 Case sizes correspond to TAZ A through H.
 Packaging information can be found on page 79.

Military Tantalum Capacitors

MIL-PRF-55365C/04

CWR09 Series



WEIBULL FAILURE RATE LEVEL GRADING

Introduction

MIL-PRF-55365C has obsoleted exponential failure rate levels (FRL) for all NEW designs, in favor of Weibull FRL. Exponential FRL will only be used on established designs.

As explained below, these two FRL distributions are similar in that both are expressed in percent per 1000 hours operation, but they use very different methods to arrive at a final level.

Exponential

Exponential FRL are based upon the results of parts on life test for 10,000 hours. These FRL are maintained and extended to lower FRL by putting additional parts on test periodically as part of Group C conformance testing. (See MIL-STD-690 and MIL-PRF-55365C for details).

The major drawback to exponential FRL is that while they are achieved with a 60% confidence level, they are maintained with only a 10% confidence level.

Weibull

Once a manufacturer achieves exponential "P" FRL on any product, they can apply for qualification to supply Weibull FRL graded parts. Weibull grading is performed on EACH LOT by placing 300 pieces, or 100% of the lot, whichever is less, on burn-in at an accelerated voltage. MIL-PRF-55365C Table XII lists the acceleration factors, and is reprinted below:

Grading Stress	Acceleration Factor (A)
1.0000	1.0000
1.1000	6.5355
1.2000	42.7128
1.3000	279.1496
1.4000	1,824.3823
1.5000	11,923.2626
1.5276	20,000.0000

Grading stress = accel.volt./rated volt.

Weibull grading can be explained by the five major steps, detailed below:

1. Parts are preconditioned for up to 15 minutes. This is to allow removal of infant mortalities.
2. The failures are counted after 2 hours of burn-in. The balance of the parts are then put back on burn-in and allowed to continue to the 40 hour point.
3. After 40 hours of burn-in, the number of additional failures are counted.
4. At that time, a calculation is performed to determine the FRL achieved and, if required the number of additional hours necessary to achieve the desired FRL.
5. The entire lot is then burned in for the total hours calculated and another FRL calculation is performed at the end of the test.

Substitutability

Because Weibull grading is performed on EACH LOT, a 90% confidence factor is associated with it. This high level of confidence, relative to exponential FRL parts, allows for liberal substitutions. MIL-PRF-55365C Table IV, reprinted on the following page shows, FRL substitutability. Note that Weibull "B" FRL is only 0.1% per 1000 hours, but it is substitutable for ALL exponential FRL, including "S" which is 0.001% per 1000 hours.

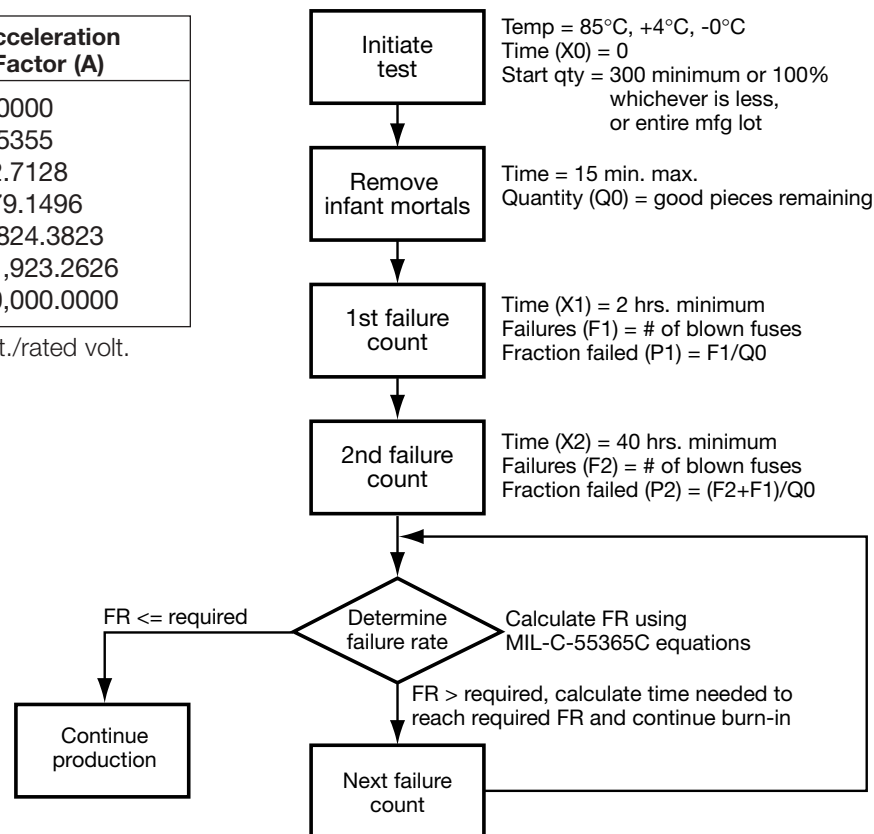

Military Tantalum Capacitors

MIL-PRF-55365/04

CWR09 Series



ELECTRICAL RATINGS FOR CWR09 CAPACITORS

MIL-PRF-55365/4 Part Number (See Note)	Case Size★	Rated Voltage (85°C) (volts)	Capacitance (nom.) (µF)	DC Leakage (max.)			Dissipation Factor (max.)			Max. ESR 100 kHz +25°C Style CWR09 (Ohms)
				+25°C (µA)	+85°C (µA)	+125°C (µA)	+25°C (%)	+85/125°C (%)	-55°C (%)	
CWR09C*225†@△□	A	4	2.2	1.0	10	12	6	8	8	8.0
CWR09C*475†@△□	B	4	4.7	1.0	10	12	6	8	8	8.0
CWR09C*685†@△□	C	4	6.8	1.0	10	12	6	8	8	5.5
CWR09C*106†@△□	D	4	10.0	1.0	10	12	8	8	10	4.0
CWR09C*156†@△□	E	4	15.0	1.0	10	12	8	10	12	3.5
CWR09C*336†@△□	F	4	33.0	2.0	20	24	8	10	12	2.2
CWR09C*686†@△□	G	4	68.0	3.0	30	36	10	12	12	1.1
CWR09C*107†@△□	H	4	100.0	4.0	40	48	10	12	12	0.9
CWR09D*155†@△□	A	6	1.5	1.0	10	12	6	8	8	8.0
CWR09D*335†@△□	B	6	3.3	1.0	10	12	6	8	8	8.0
CWR09D*475†@△□	C	6	4.7	1.0	10	12	6	8	8	5.5
CWR09D*685†@△□	D	6	6.8	1.0	10	12	6	8	8	4.5
CWR09D*106†@△□	E	6	10.0	1.0	10	12	8	10	12	3.5
CWR09D*226†@△□	F	6	22.0	2.0	20	24	8	10	12	2.2
CWR09D*476†@△□	G	6	47.0	3.0	30	36	10	12	12	1.1
CWR09D*686†@△□	H	6	68.0	4.0	40	48	10	12	12	0.9
CWR09F*105†@△□	A	10	1.0	1.0	10	12	6	8	8	10.0
CWR09F*225†@△□	B	10	2.2	1.0	10	12	6	8	8	8.0
CWR09F*335†@△□	C	10	3.3	1.0	10	12	6	8	8	5.5
CWR09F*475†@△□	D	10	4.7	1.0	10	12	6	8	8	4.5
CWR09F*685†@△□	E	10	6.8	1.0	10	12	6	8	8	3.5
CWR09F*156†@△□	F	10	15.0	2.0	20	24	8	8	10	2.5
CWR09F*336†@△□	G	10	33.0	3.0	30	36	10	12	12	1.1
CWR09F*476†@△□	H	10	47.0	5.0	50	60	10	12	12	0.9
CWR09H*684†@△□	A	15	0.68	1.0	10	12	6	8	8	12.0
CWR09H*155†@△□	B	15	1.5	1.0	10	12	6	8	8	8.0
CWR09H*225†@△□	C	15	2.2	1.0	10	12	6	8	8	5.5
CWR09H*335†@△□	D	15	3.3	1.0	10	12	6	8	8	5.0
CWR09H*475†@△□	E	15	4.7	1.0	10	12	6	8	8	4.0
CWR09H*106†@△□	F	15	10.0	2.0	20	24	6	8	8	2.5
CWR09H*226†@△□	G	15	22.0	4.0	40	48	8	8	10	1.1
CWR09H*336†@△□	H	15	33.0	5.0	50	60	8	8	10	0.9
CWR09J*474†@△□	A	20	0.47	1.0	10	12	6	8	8	14.0
CWR09J*684†@△□	B	20	0.68	1.0	10	12	6	8	8	10.0
CWR09J*105†@△□	B	20	1.0	1.0	10	12	6	8	8	12.0
CWR09J*155†@△□	C	20	1.5	1.0	10	12	6	8	8	6.0
CWR09J*225†@△□	D	20	2.2	1.0	10	12	6	8	8	5.0
CWR09J*335†@△□	E	20	3.3	1.0	10	12	6	8	8	4.0
CWR09J*685†@△□	F	20	6.8	2.0	20	24	6	8	8	2.4
CWR09J*156†@△□	G	20	15.0	3.0	30	36	6	8	8	1.1
CWR09J*226†@△□	H	20	22.0	4.0	40	48	6	8	8	0.9

NOTE: To complete the MIL-PRF-55365/04 Part Number, additional information must be added:

Contact your local AVX sales office for latest qualification status.

* = Termination Finish
 Designator:
 B = Gold Plated
 C = Hot Solder Dipped
 K = Solder Fused

† = Tolerance Code
 J = ±5%
 K = ±10%
 M = ±20%

@ = Failure Rate Level
 Exponential:
 M = 1.0% per 1000 hours
 P = 0.1% per 1000 hours
 R = 0.01% per 1000 hours
 S = 0.001% per 1000 hours
 Weibull:
 B = 0.1% per 1000 hours
 C = 0.01% per 1000 hours

△ = Optional Surge Current
 A = 10 cycles at 25°C
 B = 10 cycles at -55°C and +85°C

□ = Packaging
 Bulk Standard
 \TR = 7" Tape & Reel
 \TR13 = 13" Tape & Reel
 \W = Waffle Pack

★ The C case has limited availability. Where possible D case should be substituted.



Military Tantalum Capacitors

MIL-PRF-55365/04

CWR09 Series



ELECTRICAL RATINGS FOR CWR09 CAPACITORS

MIL-PRF-55365/4 Part Number (See Note)	Case Size★	Rated Voltage (85°C) (volts)	Capacitance (nom.) (μF)	DC Leakage (max.)			Dissipation Factor (max.)			Max. ESR 100 kHz +25°C Style CWR09 (Ohms)
				+25°C (μA)	+85°C (μA)	+125°C (μA)	+25°C (%)	+85/125°C (%)	-55°C (%)	
CWR09K*334†@Δ□	A	25	0.33	1.0	10	12	6	8	8	15.0
CWR09K*684†@Δ□	B	25	0.68	1.0	10	12	6	8	8	7.5
CWR09K*105†@Δ□	C	25	1.0	1.0	10	12	6	8	8	6.5
CWR09K*155†@Δ□	D	25	1.5	1.0	10	12	6	8	8	6.5
CWR09K*225†@Δ□	E	25	2.2	1.0	10	12	6	8	8	3.5
CWR09K*475†@Δ□	F	25	4.7	2.0	20	24	6	8	8	2.5
CWR09K*685†@Δ□	G	25	6.8	2.0	20	24	6	8	8	1.2
CWR09K*106†@Δ□	G	25	10.0	3.0	30	36	6	8	8	1.4
CWR09K*156†@Δ□	H	25	15.0	4.0	40	48	6	8	8	1.0
CWR09M*224†@Δ□	A	35	0.22	1.0	10	12	6	8	8	18.0
CWR09M*474†@Δ□	B	35	0.47	1.0	10	12	6	8	8	10.0
CWR09M*684†@Δ□	C	35	0.68	1.0	10	12	6	8	8	8.0
CWR09M*105†@Δ□	D	35	1.0	1.0	10	12	6	8	8	6.5
CWR09M*155†@Δ□	E	35	1.5	1.0	10	12	6	8	8	4.5
CWR09M*335†@Δ□	F	35	3.3	1.0	10	12	6	8	8	2.5
CWR09M*475†@Δ□	G	35	4.7	2.0	20	24	6	8	8	1.5
CWR09M*685†@Δ□	H	35	6.8	3.0	30	36	6	8	8	1.3
CWR09N*104†@Δ□	A	50	0.10	1.0	10	12	6	8	8	22.0
CWR09N*154†@Δ□	A	50	0.15	1.0	10	12	6	8	8	17.0
CWR09N*224†@Δ□	B	50	0.22	1.0	10	12	6	8	8	14.0
CWR09N*334†@Δ□	B	50	0.33	1.0	10	12	6	8	8	12.0
CWR09N*474†@Δ□	C	50	0.47	1.0	10	12	6	8	8	8.0
CWR09N*684†@Δ□	D	50	0.68	1.0	10	12	6	8	8	7.0
CWR09N*105†@Δ□	E	50	1.0	1.0	10	12	6	8	8	6.0
CWR09N*155†@Δ□	F	50	1.5	1.0	10	12	6	8	8	4.0
CWR09N*225†@Δ□	F	50	2.2	2.0	20	24	6	8	8	2.5
CWR09N*335†@Δ□	G	50	3.3	2.0	20	24	6	8	8	2.0
CWR09N*475†@Δ□	H	50	4.7	3.0	30	36	6	8	8	1.5

NOTE: To complete the MIL-PRF-55365/04 Part Number, additional information must be added:

Contact your local AVX sales office for latest qualification status.

*** = Termination Finish**

Designator:
 B = Gold Plated
 C = Hot Solder Dipped
 K = Solder Fused

† = Tolerance Code

J = ±5%
 K = ±10%
 M = ±20%

@ = Failure Rate Level

Exponential:
 M = 1.0% per 1000 hours
 P = 0.1% per 1000 hours
 R = 0.01% per 1000 hours
 S = 0.001% per 1000 hours

Weibull:

B = 0.1% per 1000 hours
 C = 0.01% per 1000 hours

Δ = Optional Surge Current

A = 10 cycles at 25°C
 B = 10 cycles at -55°C and +85°C

□ = Packaging

Bulk Standard
 \TR=7" Tape & Reel
 \TR13=13" Tape & Reel
 \W=Waffle Pack

★ The C case has limited availability. Where possible D case should be substituted.



Military Tantalum Capacitors

MIL-PRF-55365/08

CWR11 Series



MARKING

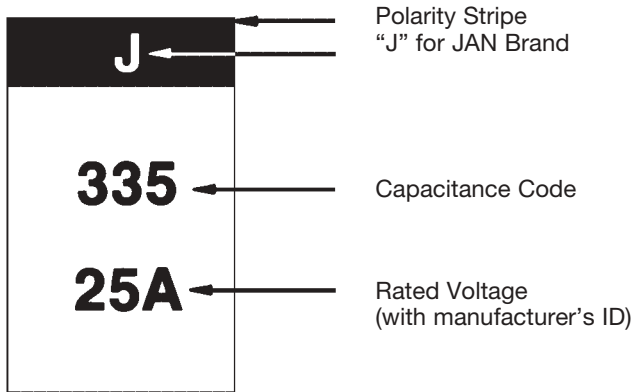

CASE DIMENSIONS:

millimeters (inches)

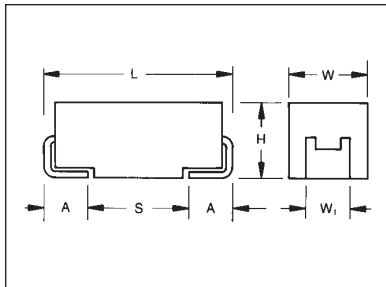

Case Code	W	L	H	W ₂ ±0.1 (±0.004)	P ±0.3 (±0.012)	H ₂ (min)
A	1.6±0.2 (0.063±0.008)	3.2±0.2 (0.126±0.008)	1.6±0.2 (0.063±0.008)	1.2 (0.047)	0.8 (0.031)	0.7 (0.028)
B	2.8±0.2 (0.110±0.008)	3.5±0.2 (0.138±0.008)	1.9±0.2 (0.075±0.008)	2.2 (0.087)	0.8 (0.031)	0.7 (0.028)
C	3.2±0.3 (0.126±0.012)	6.0±0.3 (0.236±0.012)	2.5±0.3 (0.098±0.012)	2.2 (0.087)	1.3 (0.051)	1.0 (0.039)
D	4.3±0.3 (0.169±0.012)	7.3±0.3 (0.287±0.012)	2.8±0.3 (0.110±0.012)	2.4 (0.094)	1.3 (0.051)	1.0 (0.039)

HOW TO ORDER (MIL-PRF-55365/08)

CWR11

F

A

225

K

M

A

\TR

Type

Voltage

Termination Finish

Capacitance Code

Tolerance

Failure Rate Exponential:

Optional Surge Current

Packaging Bulk

C = 4
D = 6
F = 10
H = 15
J = 20
K = 25
M = 35
N = 50

B = Gold Plated
C = Hot Solder Dipped
K = Solder Fused

J = ±5%
K = ±10%
M = ±20%

M = 1%/1000 hours
P = 0.1%/1000 hours
R = 0.01%/1000 hours
S = 0.001%/1000 hours

Weibull:
B = 0.1%/1000 hours
C = 0.01%/1000 hours
D = 0.001%/1000 hours

A = 10 cycles at 25°C
B = 10 cycles at -55°C and +85°C

(Standard if nothing is specified in this position)
\TR = 7" Tape & Reel
\TR13 = 13" Tape & Reel
\W = Waffle Pack

Military Tantalum Capacitors

MIL-PRF-55365/08

CWR11 Series



ELECTRICAL RATINGS FOR CWR11 CAPACITORS

MIL-PRF-55365/8 Part Number (See Note)	Case Size	Rated Voltage (85°C) (volts)	Capacitance (nom.) (μF)	DC Leakage (max.)			Dissipation Factor (max.)			Max. ESR 100 kHz (Ω)
				+25°C (μA)	+85°C (μA)	+125°C (μA)	+25°C (%)	+85/125°C (%)	-55°C (%)	
CWR11D*155†@Δ□	A	6	1.5	0.5	5.0	6.0	6	9	9	8.0
CWR11D*225†@Δ□	A	6	2.2	0.5	5.0	6.0	6	6	9	8.0
CWR11D*335†@Δ□	A	6	3.3	0.5	5.0	6.0	6	9	9	8.0
CWR11D*475†@Δ□	B	6	4.7	0.5	5.0	6.0	6	9	9	5.5
CWR11D*685†@Δ□	B	6	6.8	0.5	5.0	6.0	6	6	9	4.5
CWR11D*106†@Δ□	B	6	10.0	0.6	6.0	7.2	6	9	9	3.5
CWR11D*156†@Δ□	C	6	15.0	0.9	9.0	10.8	6	6	9	3.0
CWR11D*226†@Δ□	C	6	22.0	1.4	14.0	16.8	6	9	9	2.2
CWR11D*476†@Δ□	D	6	47.0	2.8	28.0	33.6	6	6	9	1.1
CWR11F*105†@Δ□	A	10	1.0	0.5	5.0	6.0	4	6	6	10.0
CWR11F*155†@Δ□	A	10	1.5	0.5	5.0	6.0	6	6	9	8.0
CWR11F*225†@Δ□	A	10	2.2	0.5	5.0	6.0	6	9	9	8.0
CWR11F*335†@Δ□	B	10	3.3	0.5	5.0	6.0	6	9	9	5.5
CWR11F*475†@Δ□	B	10	4.7	0.5	5.0	6.0	6	9	9	4.5
CWR11F*685†@Δ□	B	10	6.8	0.7	7.0	8.4	6	9	9	3.5
CWR11F*156†@Δ□	C	10	15.0	1.5	15.0	18.0	6	6	9	2.5
CWR11F*336†@Δ□	D	10	33.0	3.3	33.0	39.6	6	6	9	1.1
CWR11H*684†@Δ□	A	15	0.68	0.5	5.0	6.0	4	6	6	12.0
CWR11H*105†@Δ□	A	15	1.0	0.5	5.0	6.0	4	6	9	10.0
CWR11H*155†@Δ□	A	15	1.5	0.5	5.0	6.0	6	9	9	8.0
CWR11H*225†@Δ□	B	15	2.2	0.5	5.0	6.0	6	9	9	5.5
CWR11H*335†@Δ□	B	15	3.3	0.5	5.0	6.0	6	8	9	5.0
CWR11H*475†@Δ□	B	15	4.7	0.7	7.0	8.4	6	9	9	4.0
CWR11H*106†@Δ□	C	15	10.0	1.6	16.0	19.2	6	8	9	2.5
CWR11H*226†@Δ□	D	15	22.0	3.3	33.0	39.6	6	8	9	1.1
CWR11J*474†@Δ□	A	20	0.47	0.5	5.0	6.0	4	6	6	14.0
CWR11J*684†@Δ□	A	20	0.68	0.5	5.0	6.0	4	6	6	12.0
CWR11J*105†@Δ□	A	20	1.0	0.5	5.0	6.0	4	6	6	10.0
CWR11J*155†@Δ□	B	20	1.5	0.5	5.0	6.0	6	9	9	6.0
CWR11J*225†@Δ□	B	20	2.2	0.5	5.0	6.0	6	8	9	5.0
CWR11J*335†@Δ□	B	20	3.3	0.7	7.0	8.4	6	9	9	4.0
CWR11J*475†@Δ□	C	20	4.7	1.0	10.0	12.0	6	8	9	3.0
CWR11J*685†@Δ□	C	20	6.8	1.4	14.0	16.8	6	9	9	2.4
CWR11J*156†@Δ□	D	20	15.0	3.0	30.0	36.0	6	8	9	1.1

NOTE: To complete the MIL-PRF-55365/08 Part Number, additional information must be added:

Contact your local AVX sales office for latest qualification status.

*** = Termination Finish**

Designator:
B = Gold Plated
C = Hot Solder Dipped
K = Solder Fused

† = Tolerance Code

J = ±5%
K = ±10%
M = ±20%

@ = Failure Rate Level

Exponential:
M = 1.0% per 1000 hours
P = 0.1% per 1000 hours
R = 0.01% per 1000 hours
S = 0.001% per 1000 hours

Weibull:

B = 0.1% per 1000 hours
C = 0.01% per 1000 hours
D = 0.001% Per 1000 hours

Δ = Optional Surge Current

A = 10 cycles at 25°C
B = 10 cycles at -55°C and +85°C

□ = Packaging

Bulk Standard
TR=7" Tape & Reel
TR13=13" Tape & Reel
W=Waffle Pack



Military Tantalum Capacitors

MIL-PRF-55365/08

CWR11 Series



ELECTRICAL RATINGS FOR CWR11 CAPACITORS

MIL-PRF-55365/8 Part Number (See Note)	Case Size	Rated Voltage (85°C) (volts)	Capacitance (nom.) (µF)	DC Leakage (max.)			Dissipation Factor (max.)			Max. ESR 100 kHz (Ω)
				+25°C (µA)	+85°C (µA)	+125°C (µA)	+25°C (%)	+85/125°C (%)	-55°C (%)	
CWR11K*334†@△□	A	25	0.33	0.5	5.0	6.0	4	6	6	15.0
CWR11K*474†@△□	A	25	0.47	0.5	5.0	6.0	4	6	6	14.0
CWR11K*684†@△□	B	25	0.68	0.5	5.0	6.0	4	6	6	7.5
CWR11K*105†@△□	B	25	1.0	0.5	5.0	6.0	4	6	6	6.5
CWR11K*155†@△□	B	25	1.5	0.5	5.0	6.0	6	8	9	6.5
CWR11K*225†@△□	C	25	2.2	0.6	6.0	7.2	6	9	9	3.5
CWR11K*335†@△□	C	25	3.3	0.9	9.0	10.8	6	8	9	3.5
CWR11K*475†@△□	C	25	4.7	1.2	12.0	14.4	6	9	9	2.5
CWR11K*685†@△□	D	25	6.8	1.7	17.0	20.4	6	9	9	1.4
CWR11K*106†@△□	D	25	10.0	2.5	25.0	30.0	6	8	9	1.2
CWR11M*104†@△□	A	35	0.10	0.5	5.0	6.0	4	6	6	24.0
CWR11M*154†@△□	A	35	0.15	0.5	5.0	6.0	4	6	6	21.0
CWR11M*224†@△□	A	35	0.22	0.5	5.0	6.0	4	6	6	18.0
CWR11M*334†@△□	A	35	0.33	0.5	5.0	6.0	4	6	6	15.0
CWR11M*474†@△□	B	35	0.47	0.5	5.0	6.0	4	6	6	10.0
CWR11M*684†@△□	B	35	0.68	0.5	5.0	6.0	4	6	6	8.0
CWR11M*105†@△□	B	35	1.0	0.5	5.0	6.0	4	6	6	6.5
CWR11M*155†@△□	C	35	1.5	0.5	5.0	6.0	6	8	9	4.5
CWR11M*225†@△□	C	35	2.2	0.8	8.0	9.6	6	8	9	3.5
CWR11M*335†@△□	C	35	3.3	1.2	12.0	14.4	6	8	9	2.5
CWR11M*475†@△□	D	35	4.7	1.7	17.0	20.4	6	8	9	1.5
CWR11N*104†@△□	A	50	0.10	0.5	5.0	6.0	4	6	6	22.0
CWR11N*154†@△□	B	50	0.15	0.5	5.0	6.0	4	6	6	17.0
CWR11N*224†@△□	B	50	0.22	0.5	5.0	6.0	4	6	6	14.0
CWR11N*334†@△□	B	50	0.33	0.5	5.0	6.0	4	6	6	12.0
CWR11N*474†@△□	C	50	0.47	0.5	5.0	6.0	4	6	6	8.0
CWR11N*684†@△□	C	50	0.68	0.5	5.0	6.0	6	6	6	7.0
CWR11N*105†@△□	C	50	1.0	0.5	5.0	6.0	6	6	6	6.0
CWR11N*155†@△□	D	50	1.5	0.8	8.0	9.6	6	8	9	4.0
CWR11N*225†@△□	D	50	2.2	1.1	11.0	13.2	6	8	9	2.5

NOTE: To complete the MIL-PRF-55365/08 Part Number, additional information must be added:

Contact your local AVX sales office for latest qualification status.

*** = Termination Finish**

Designator:
 B = Gold Plated
 C = Hot Solder Dipped
 K = Solder Fused

† = Tolerance Code

J = ±5%
 K = ±10%
 M = ±20%

@ = Failure Rate Level

Exponential:
 M = 1.0% per 1000 hours
 P = 0.1% per 1000 hours
 R = 0.01% per 1000 hours
 S = 0.001% per 1000 hours

Weibull:

B = 0.1% per 1000 hours
 C = 0.01% per 1000 hours
 D = 0.001% per 1000 hours

△ = Optional Surge Current

A = 10 cycles at 25°C
 B = 10 cycles at -55°C and +85°C

□ = Packaging

Bulk Standard
 \TR=7" Tape & Reel
 \TR13=13" Tape & Reel
 \W=Waffle Pack



TAZ Series



Including CWR09 and COTS-Plus

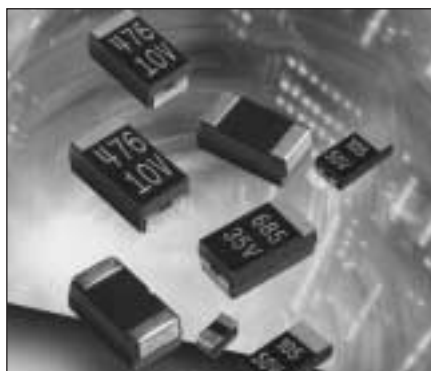

The TAZ part has fully molded, compliant leadframe construction designed for use in applications utilizing solder (Reflow, Wave or Vapor Phase), conductive adhesive or thermal compression bonding techniques. Each chip is marked with polarity, capacitance code and rated voltage.

The series comprises eight case sizes (see dimensional chart below) with the new V case enabling capacitance values to 470 μ F. The C case, with its non-standard aspect ratio, is retained as a QPL (Qualified Product List) only special.

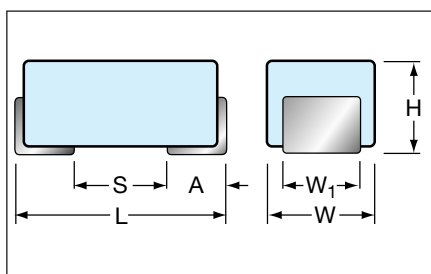

TAZ & CWR09 CASE DIMENSIONS: millimeters (inches)

Case Code	Length (L) ± 0.38 (0.015)	Width (W) ± 0.38 (0.015)	Height (H) ± 0.38 (0.015)	Term. Width (W_1)	Term. Length (A) ± 0.13 (0.005)	S min
A	2.54 (0.100)	1.27 (0.050)	1.27 (0.050)	1.27 \pm 0.13 (0.050 \pm 0.005)	0.76 (0.030)	0.38 (0.015)
B	3.81 (0.150)	1.27 (0.050)	1.27 (0.050)	1.27 \pm 0.13 (0.050 \pm 0.005)	0.76 (0.030)	1.65 (0.065)
D	3.81 (0.150)	2.54 (0.100)	1.27 (0.050)	2.41 \pm 0.13/-0.25 (0.095 \pm 0.005/-0.010)	0.76 (0.030)	1.65 (0.065)
E	5.08 (0.200)	2.54 (0.100)	1.27 (0.050)	2.41 \pm 0.13/-0.25 (0.095 \pm 0.005/-0.010)	0.76 (0.030)	2.92 (0.115)
F	5.59 (0.220)	3.43 (0.135)	1.78 (0.070)	3.30 \pm 0.13 (0.130 \pm 0.005)	0.76 (0.030)	3.43 (0.135)
G	6.73 (0.265)	2.79 (0.110)	2.79 (0.110)	2.67 \pm 0.13 (0.105 \pm 0.005)	1.27 (0.050)	3.56 (0.140)
H	7.24 (0.285)	3.81 (0.150)	2.79 (0.110)	3.68 \pm 0.13/-0.51 (0.145 \pm 0.005/-0.020)	1.27 (0.050)	4.06 (0.160)
V	7.30 \pm 0.30 (0.287 \pm 0.012)	6.10 \pm 0.200 (0.240 \pm 0.008)	3.45 \pm 0.30 (0.136 \pm 0.012)	3.10 (0.120)	1.40 \pm 0.30/-0.20 (0.550 \pm 0.012/-0.008)	4.40 (0.173)

MARKING

(White marking on black body)



Polarity Stripe (+)
Capacitance Code
Rated Voltage

Case sizes A through E share a common (0.050" nom) height profile, compatible with PCMCIA type II applications. These allow downsizing in all portable applications, ranging from sub-miniature hard-disc drive (HDD)/computer to portable communications/GPS systems. The F case at 0.070" nom offers the versatility of a low profile design, while allowing capacitance ratings to 100 μ F for low voltage filtering applications.

Cases G and H offer lower profile and greater volumetric efficiency than their nearest EIA sized counterparts (ref. CWR11). These are especially suited to power supply applications. The regular configuration allows for banking (brickwalling) applications where maximum capacitance with minimal ESR and inductance are required in a limited board space.

TAZ Series



Including CWR09 and COTS-Plus

Technical Data:	Unless otherwise specified, all technical data relate to an ambient temperature of 25°C									
Capacitance Range:	0.1 to 470 μ F									
Capacitance Tolerance:	\pm 20%, \pm 10%, \pm 5%									
Rated DC Voltage: (V_R)	\leq 85°C:	4	6	10	15	20	25	35	50	
Category Voltage: (V_C)	125°C:	2.7	4	7	10	13	17	23	33	
Surge Voltage: (V_C)	\leq 85°C:	5.2	8	13	20	26	33	46	65	
	125°C:	3.5	5	9	12	16	21	28	40	
Operating Temperature Range:	-55°C to +125°C									

CWR09 - MIL-PRF-55365/04

Fully qualified to MIL-PRF-55365/04, this series represents the most flexible of surface mount form factors, offering eight case sizes (A through H). This series is fully interchangeable with CWR06 conformal types, while offering the advantages of molded body/compliant termination construction, polarity, capacitance and JAN brand packaging. The molded construction is compatible with a wide range of SMT board assembly processes including wave or reflow solder, conductive epoxy or compression bonding techniques. The five

smaller cases are characterized by their low profile construction, with the A case being the world's smallest molded military tantalum. There are three termination finishes available: fused solder plated ("K" per MIL-PRF-55365), hot solder dipped ("C") and gold plated ("B"). In addition, the molding compound has been selected to meet the requirements of UL94V-0 and outgassing requirements of NASA SP-R-0022A.

PART NUMBERING SYSTEM

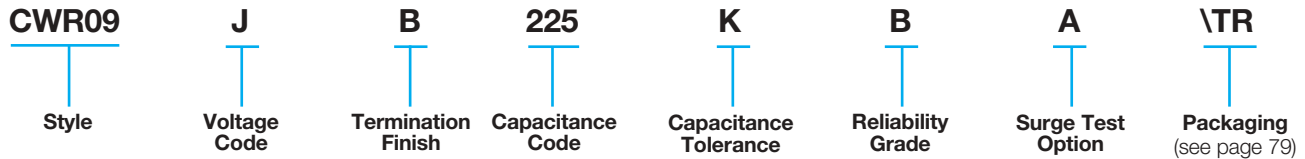

TAZ COTS-Plus SERIES

This series features:

- CWR09 form factor in Standard and Extended ratings.
- Low Profile molded design (Cases A through E).
- Low ESR Ratings (Cases G through V).
- Extended Case size (V) for ratings to 470 μ F.
- Weibull Reliability Grading and Surge Test options.

All ratings in this series offer the advantages of molded body/compliant termination construction, polarity, capacitance and voltage marking. The molded construction is compatible with a wide range of SMT board assembly processes including wave or reflow solder, conductive epoxy or compression bonding techniques.

PART NUMBERING SYSTEM

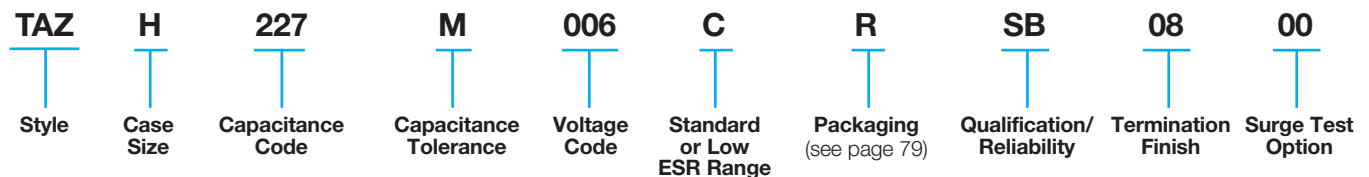

CWR19/CWR29-MIL-PRF-55365/11

As the CWRxx part numbering system does not include a case size reference, many available ratings are not included in the current QPL Matrix. These ratings are being added as CWR19 (Standard) and CWR29 (Low ESR) Series. These are currently under qualification to MIL-PRF-55365 but are available as Established Reliability Product and may be ordered by their TAZ part number reference.

When released, CWR19 and CWR29 part numbers will contain a case size reference.

For more details on qualification status, contact AVX.



Surface Mount Military



CWR09 - MIL-PRF-55365/04 and TAZ COTS-Plus

AVX Part Number	QPL Part Number (for reference only)	DC rated voltage (85°C) (volts)	Cap (nom) µF	DC Leakage (max)			Dissipation Factor (max)			ESR (max) 100 kHz +25°C (Ohms)	Case Size
				+25°C (µA)	+85°C (µA)	+125°C (µA)	+25°C (%)	+85/125°C (%)	-55°C (%)		
TAZA225*004C□#@0^++	CWR09C^225*@+□	4	2.2	1.0	10	12	6	8	8	8.0	A
TAZA475*004C□#@0^++	CWR19C^475*@+□	4	4.7	1.0	10	12	6	8	8	12.0	A
TAZB475*004C□#@0^++	CWR09C^475*@+□	4	4.7	1.0	10	12	6	8	8	8.0	B
TAZA685*004C□#@0^++	CWR19C^685*@+□	4	6.8	0.272	2.72	3.264	6	8	8	12	A
TAZB106*004C□#@0^++	CWR19C^106*@+□	4	10.0	1.0	10	12	8	10	10	8.0	B
TAZD106*004C□#@0^++	CWR09C^106*@+□	4	10.0	1.0	10	12	8	8	10	4.0	D
TAZB156*004C□#@0^++	CWR19C^156*@+□	4	15	0.6	6	7.2	6	8	8	8	B
TAZE156*004C□#@0^++	CWR09C^156*@+□	4	15.0	1.0	10	12	8	10	12	3.5	E
TAZB226*004C□#@0^++	CWR19C^226*@+□	4	22	0.88	8.8	10.56	6	8	8	10	B
TAZD226*004C□#@0^++	CWR19C^226*@+□	4	22.0	1.0	10	12	8	10	12	4.0	D
TAZD336*004C□#@0^++	CWR19C^336*@+□	4	33	1.32	13.2	15.84	8	10	12	4	D
TAZE336*004C□#@0^++	CWR19C^336*@+□	4	33.0	2.0	20	24	8	10	12	3.0	E
TAZF336*004C□#@0^++	CWR09C^336*@+□	4	33.0	2.0	20	24	8	10	12	2.2	F
TAZE476*004C□#@0^++	CWR19C^476*@+□	4	47	1.88	18.8	22.56	8	10	12	3	E
TAZE686*004C□#@0^++	CWR19C^686*@+□	4	68	2.72	27.2	32.64	8	10	12	3	E
TAZG686*004C□#@0^++	CWR09C^686*@+□	4	68.0	3.0	30	36	10	12	12	1.1	G
TAZF107*004C□#@0^++	CWR19C^107*@+□	4	100.0	4.0	40	48	10	12	12	2.0	F
TAZH107*004C□#@0^++	CWR09C^107*@+□	4	100.0	4.0	40	48	10	12	12	0.9	H
TAZG157*004C□#@0^++	CWR19C^157*@+□	4	150.0	6.0	60	72	10	12	12	1.0	G
TAZG227*004C□#@0^++	CWR19C^227*@+□	4	220	8.8	88	105.6	10	12	12	—	G
TAZH337*004C□#@0^++	CWR19C^337*@+□	4	330	13.2	132	158.4	10	12	12	—	H
TAZA155*006C□#@0^++	CWR09D^155*@+□	6	1.5	1.0	10	12	6	8	8	8.0	A
TAZA335*006C□#@0^++	CWR19C^335*@+□	6	3.3	1.0	10	12	6	8	8	12.0	A
TAZB335*006C□#@0^++	CWR09D^335*@+□	6	3.3	1.0	10	12	6	8	8	8.0	B
TAZA475*006C□#@0^++	CWR19C^475*@+□	6	4.7	0.282	2.82	3.384	6	8	8	12	A
TAZB685*006C□#@0^++	CWR19C^685*@+□	6	6.8	1.0	10	12	6	8	8	8.0	B
TAZD685*006C□#@0^++	CWR09D^685*@+□	6	6.8	1.0	10	12	6	8	8	4.5	D
TAZB106*006C□#@0^++	CWR19C^106*@+□	6	10	0.6	6	7.2	6	8	8	8	B
TAZE106*006C□#@0^++	CWR09D^106*@+□	6	10.0	1.0	10	12	8	10	12	3.5	E
TAZB156*006C□#@0^++	CWR19D^156*@+□	6	15	0.9	9	10.8	6	8	8	12	B
TAZD156*006C□#@0^++	CWR19D^156*@+□	6	15.0	1.0	10	12	8	10	12	5.0	D
TAZD226*006C□#@0^++	CWR19D^226*@+□	6	22	1.32	13.2	15.84	6	8	8	5	D
TAZE226*006C□#@0^++	CWR19D^226*@+□	6	22.0	2.0	20	24	8	10	12	3.5	E
TAZF226*006C□#@0^++	CWR09D^226*@+□	6	22.0	2.0	20	24	8	10	12	2.2	F
TAZE336*006C□#@0^++	CWR19D^336*@+□	6	33	1.98	19.8	23.76	6	8	8	3.5	E
TAZG476*006C□#@0^++	CWR09D^476*@+□	6	47.0	3.0	30	36	10	12	12	1.1	G
TAZF686*006C□#@0^++	CWR19D^686*@+□	6	68.0	4.0	40	48	10	12	12	1.5	F
TAZH686*006C□#@0^++	CWR09D^686*@+□	6	68.0	4.0	40	48	10	12	12	0.9	H
TAZG107*006C□#@0^++	CWR19D^107*@+□	6	100.0	6.0	60	72	10	12	12	1.1	G
TAZG107*006L□#@0^++	CWR29C^107*@+□	6	100.0	6.0	60	72	10	12	12	0.150	G
TAZG157*006C□#@0^++	CWR19C^157*@+□	6	150	9	90	108	10	12	12	1.1	G
TAZH227*006C□#@0^++	CWR19C^227*@+□	6	220.0	10.0	100	120	10	12	12	0.9	H
TAZH227*006L□#@0^++	CWR29C^227*@+□	6	220.0	10.0	100	120	10	12	12	0.100	H
TAZH337*006C□#@0^++	CWR19C^337*@+□	6	330	19.8	198	237.6	10	12	12	1	H

Following the voltage code, C designates Standard, L designates Low ESR Ratings

CWR19, CWR29 DESIGNATIONS ARE INCLUDED FOR REFERENCE ONLY – USE TAZ P/N TO ORDER

Part Number Designations

^ = Termination Finish:¹

For TAZ p/n:
9 = Gold Plated
8 = Hot Solder Dipped
0 = Solder Fused

For CWR p/n:
B = Gold Plated
C = Hot Solder Dipped
K = Solder Fused

= Inspection Level:

S = Std. Conformance
L = Optional Group A
For CWR p/n:
M = Military

Conformance per
MIL-PRF-55365

*** = Tolerance:**

M = ±20%
K = ±10%
J = ±5% (Special
order only)

@ = Failure Rate Level:

Weibull: B = 0.1%/1000 Hrs.
(90% C = 0.01%/1000 Hrs.
conf.)
Comm: Z = Non ER

+ = Surge Option:

For TAZ p/n:
00 = None
23 = 10 cycles, +25°C
24 = 10 cycles,
-55°C & +85°C

For CWR p/n:
A = 10 cycles, +25°C
B = 10 cycles,
-55°C & +85°C

□ = Packaging:

For TAZ p/n:
B = Bulk
R = 7" T&R
S = 13" T&R
For CWR p/n:
Bulk = Standard
VTR = 7" T&R
VTR13 = 13" T&R
W = Waffle



Surface Mount Military



CWR09 - MIL-PRF-55365/04 and TAZ COTS-Plus

AVX Part Number	QPL Part Number (for reference only)	DC rated voltage (85°C) (volts)	Cap (nom) µF	DC Leakage (max)			Dissipation Factor (max)			ESR (max) 100 kHz +25°C (Ohms)	Case Size
				+25°C (µA)	+85°C (µA)	+125°C (µA)	+25°C (%)	+85/125°C (%)	-55°C (%)		
TAZA105*010C□#@0^++	CWR09F^105*@+□	10	1.0	1.0	10	12	6	8	8	10.0	A
TAZA225*010C□#@0^++	CWR19F^225*@+□	10	2.2	1.0	10	12	6	8	8	12.0	A
TAZB225*010C□#@0^++	CWR09F^225*@+□	10	2.2	1.0	10	12	6	8	8	8.0	B
TAZA335*010C□#@0^++	CWR19F^335*@+□	10	3.3	0.33	3.3	3.96	6	8	8	12	A
TAZB475*010C□#@0^++	CWR19F^475*@+□	10	4.7	1.0	10	12	6	8	8	8.0	B
TAZD475*010C□#@0^++	CWR09F^475*@+□	10	4.7	1.0	10	12	6	8	8	4.5	D
TAZB685*010C□#@0^++	CWR19F^685*@+□	10	6.8	0.68	6.8	8.16	6	8	8	8	B
TAZD685*010C□#@0^++	CWR19F^685*@+□	10	6.8	1.0	10	12	6	8	8	5.0	D
TAZE685*010C□#@0^++	CWR09F^685*@+□	10	6.8	1.0	10	12	6	8	8	3.5	E
TAZB106*010C□#@0^++	CWR19F^106*@+□	10	10	1	12	12	6	8	8	12	B
TAZD106*010C□#@0^++	CWR19F^106*@+□	10	10.0	1.0	10	12	6	8	8	4.0	D
TAZD156*010C□#@0^++	CWR19F^156*@+□	10	15	1.5	15	18	6	8	8	5	D
TAZE156*010C□#@0^++	CWR19F^156*@+□	10	15.0	2.0	20	24	8	10	10	3.0	E
TAZF156*010C□#@0^++	CWR09F^156*@+□	10	15.0	2.0	20	24	8	8	10	2.5	F
TAZD226*010C□#@0^++		10	22	2.2	22	26.4	6	8	8	4	D
TAZE226*010C□#@0^++	CWR19F^226*@+□	10	22.0	3.0	30	36	8	10	10	2.0	E
TAZF336*010C□#@0^++	CWR19F^336*@+□	10	33	3.3	33	39.6	8	10	12	1.5	F
TAZG336*010C□#@0^++	CWR09F^336*@+□	10	33.0	3.0	30	36	10	12	12	1.1	G
TAZF476*010C□#@0^++	CWR19F^476*@+□	10	47.0	4.0	40	48	10	12	12	1.5	F
TAZH476*010C□#@0^++	CWR09F^476*@+□	10	47.0	5.0	50	60	10	12	12	0.9	H
TAZG686*010C□#@0^++	CWR19F^686*@+□	10	68.0	6.0	60	72	10	12	12	1.1	G
TAZG686*010L□#@0^++	CWR29F^686*@+□	10	68.0	6.0	60	72	10	12	12	0.200	G
TAZG107*010C□#@0^++	CWR19F^107*@+□	10	100	10	100	120	10	12	12	1.1	G
TAZH107*010C□#@0^++	CWR19F^107*@+□	10	100.0	10.0	100	120	10	12	12	0.9	H
TAZH107*010L□#@0^++	CWR29F^107*@+□	10	100.0	10.0	100	120	10	12	12	0.100	H
TAZH157*010C□#@0^++	CWR19F^157*@+□	10	150.0	15.0	150	180	10	12	12	0.9	H
TAZH157*010L□#@0^++	CWR29F^157*@+□	10	150.0	15.0	150	180	10	12	12	0.100	H
TAZH227*010C□#@0^++	CWR19F^227*@+□	10	220	22	220	264	10	12	12	1	H
TAZV337*010L□#@0^++		10	330	33	330	660	8	10	12	0.1	V
TAZV477(*)010L□#@00++		10	470.0	47.0	470	940	10	12	14	0.100	V

Following the voltage code, C designates Standard, L designates Low ESR Ratings

CWR19, CWR29 DESIGNATIONS ARE INCLUDED FOR REFERENCE ONLY – USE TAZ P/N TO ORDER

Part Number Designations

^ = Termination Finish:¹
For TAZ p/n:

9 = Gold Plated
8 = Hot Solder Dipped
0 = Solder Fused

For CWR p/n:
B = Gold Plated
C = Hot Solder Dipped
K = Solder Fused

= Inspection Level:
S = Std. Conformance
L = Optional Group A

For CWR p/n:
M = Military
Conformance per
MIL-PRF-55365

*** = Tolerance:**
M = ±20%
K = ±10%
J = ±5% (Special
order only)

@ = Failure Rate Level:
Weibull: B = 0.1%/1000 Hrs.
(90% C = 0.01%/1000 Hrs.
conf.)
Comm: Z = Non ER

+ = Surge Option:
For TAZ p/n:
00 = None
23 = 10 cycles, +25°C
24 = 10 cycles,
-55°C & +85°C

For CWR p/n:
A = 10 cycles, +25°C
B = 10 cycles,
-55°C & +85°C

□ = Packaging:
For TAZ p/n:

B = Bulk
R = 7" T&R
S = 13" T&R

For CWR p/n:
Bulk = Standard
VTR = 7" T&R
VTR13 = 13" T&R
W = Waffle

Surface Mount Military



CWR09 - MIL-PRF-55365/04 and TAZ COTS-Plus

AVX Part Number	QPL Part Number (for reference only)	DC rated voltage (85°C) (volts)	Cap (nom) µF	DC Leakage (max)			Dissipation Factor (max)			ESR (max) 100 kHz +25°C (Ohms)	Case Size
				+25°C (µA)	+85°C (µA)	+125°C (µA)	+25°C (%)	+85/125°C (%)	-55°C (%)		
TAZA684*015C□#@0^++	CWR09H^684*@+□	15	0.68	1.0	10	12	6	8	8	12.0	A
TAZA105*015C□#@0^++	CWR19H^105*@+□	15	1.0	1.0	10	12	6	8	8	15.0	A
TAZA155*015C□#@0^++	CWR19H^155*@+□	15	1.5	0.225	2.25	2.7	6	8	8	15	A
TAZB155*015C□#@0^++	CWR09H^155*@+□	15	1.5	1.0	10	12	6	8	8	8.0	B
TAZA225*015C□#@0^++	CWR19H^225*@+□	15	2.2	0.33	3.3	3.96	6	8	9	15	A
TAZB335*015C□#@0^++	CWR19H^335*@+□	15	3.3	1.0	10	12	6	8	8	9.0	B
TAZD335*015C□#@0^++	CWR09H^335*@+□	15	3.3	1.0	10	12	6	8	8	5.0	D
TAZB475*015C□#@0^++	CWR19H^475*@+□	15	4.7	0.705	7.05	8.46	6	8	8	5	B
TAZD475*015C□#@0^++	CWR19H^475*@+□	15	4.7	1.0	10	12	6	8	8	6.0	D
TAZE475*015C□#@0^++	CWR09H^475*@+□	15	4.7	1.0	10	12	6	8	8	4.0	E
TAZD685*015C□#@0^++	CWR19H^685*@+□	15	6.8	1.02	10.2	12.24	6	8	8	6	D
TAZD106*015C□#@0^++	CWR19H^106*@+□	15	10	1.5	15	18	6	8	8	6	D
TAZE106*015C□#@0^++	CWR19H^106*@+□	15	10.0	2.0	20	24	6	8	8	4.0	E
TAZF106*015C□#@0^++	CWR09H^106*@+□	15	10.0	2.0	20	24	6	8	8	2.5	F
TAZE156*015C□#@0^++	CWR19H^156*@+□	15	15	2.25	22.5	27	6	8	8	4	E
TAZF226*015C□#@0^++	CWR19H^226*@+□	15	22.0	3.0	30	36	8	10	10	3.0	F
TAZG226*015C□#@0^++	CWR09H^226*@+□	15	22.0	4.0	40	48	6	8	8	1.1	G
TAZF336*015C□#@0^++	CWR19H^336*@+□	15	33	4.95	49.5	59.4	6	8	8	3	F
TAZH336*015C□#@0^++	CWR09H^336*@+□	15	33.0	5.0	50	60	8	8	10	0.9	H
TAZG476*015C□#@0^++	CWR19H^476*@+□	15	47	7.05	70.5	84.6	8	10	12	1.1	G
TAZG476*015C□#@0^++	CWR19H^476*@+□	15	68	10.2	102	122.4	8	10	12	1.1	G
TAZH686*015C□#@0^++	CWR19H^686*@+□	15	68.0	10.0	100	120	8	10	12	0.9	H
TAZH686*015L□#@0^++	CWR29H^686*@+□	15	68.0	10.0	100	120	8	10	12	0.150	H
TAZH107*015C□#@0^++	CWR19H^107*@+□	15	100.0	15.0	150	180	10	12	12	0.9	H
TAZH107*015L□#@0^++	CWR29H^107*@+□	15	100.0	15.0	150	180	10	12	12	0.125	H
TAZV227(*)016L□#@00++		16	220.0	35.2	352	704	8	10	12	0.150	V
TAZA474*020C□#@0^++	CWR09J^474*@+□	20	0.47	1.0	10	12	6	8	8	14.0	A
TAZA684*020C□#@0^++	CWR19J^684*@+□	20	0.68	1.0	10	12	6	8	8	15.0	A
TAZB684*020C□#@0^++	CWR09J^684*@+□	20	0.68	1.0	10	12	6	8	8	10.0	B
TAZA105*020C□#@0^++	CWR19J^105*@+□	20	1.0	0.2	2.0	2.4	6	8	8	15	A
TAZB105*020C□#@0^++	CWR09J^105*@+□	20	1.0	1.0	10	12	6	8	8	12.0	B
TAZB155*020C□#@0^++	CWR19J^155*@+□	20	1.5	0.3	3.0	3.6	6	8	8	9.0	B
TAZB225*020C□#@0^++	CWR19J^225*@+□	20	2.2	1.0	10	12	6	8	8	9.0	B
TAZD225*020C□#@0^++	CWR09J^225*@+□	20	2.2	1.0	10	12	6	8	8	5.0	D
TAZD335*020C□#@0^++	CWR19J^335*@+□	20	3.3	1.0	10	12	6	8	8	6.0	D
TAZE335*020C□#@0^++	CWR09J^335*@+□	20	3.3	1.0	10	12	6	8	8	4.0	E
TAZE475*020C□#@0^++	CWR19J^475*@+□	20	4.7	1.0	10	12	6	8	8	6.0	E
TAZE685*020C□#@0^++	CWR19J^685*@+□	20	6.8	2.0	20	24	6	8	8	5.0	E
TAZF685*020C□#@0^++	CWR09J^685*@+□	20	6.8	2.0	20	24	6	8	8	2.4	F
TAZF106*020C□#@0^++	CWR19J^106*@+□	20	10.0	2.0	20	24	6	8	8	3.0	F
TAZF156*020C□#@0^++	CWR19J^156*@+□	20	15.0	3.0	30	36	6	8	8	3.0	F
TAZG156*020C□#@0^++	CWR09J^156*@+□	20	15.0	3.0	30	36	6	8	8	1.1	G
TAZG226*020C□#@0^++	CWR19J^226*@+□	20	22.0	4.0	40	48	6	8	8	2.5	G
TAZG226*020L□#@0^++	CWR29J^226*@+□	20	22.0	4.0	40	48	6	8	8	0.500	G
TAZH226*020C□#@0^++	CWR09J^226*@+□	20	22.0	4.0	40	48	6	8	8	0.9	H
TAZH336*020C□#@0^++	CWR19J^336*@+□	20	33.0	6.6	66	79.2	8	10	12	0.9	H
TAZH476*020C□#@0^++	CWR19J^476*@+□	20	47.0	10.0	100	120	8	10	10	0.9	H
TAZH476*020L□#@0^++	CWR29J^476*@+□	20	47.0	10.0	100	120	8	10	10	0.250	H
TAZV107(*)020L□#@00++		20	100.0	20.0	200	400	8	10	12	0.200	V

Following the voltage code, C designates Standard, L designates Low ESR Ratings

CWR19, CWR29 DESIGNATIONS ARE INCLUDED FOR REFERENCE ONLY - USE TAZ P/N TO ORDER

Part Number Designations

^ = Termination Finish:
For TAZ p/n:

- 9 = Gold Plated
- 8 = Hot Solder Dipped
- 0 = Solder Fused

For CWR p/n:
B = Gold Plated
C = Hot Solder Dipped
K = Solder Fused

= Inspection Level:

- S = Std. Conformance
 - L = Optional Group A
- For CWR p/n:**
M = Military
Conformance per MIL-PRF-55365

*** = Tolerance:**

- M = ±20%
- K = ±10%
- J = ±5% (Special order only)

@ = Failure Rate Level:

- Weibull: B = 0.1%/1000 Hrs.
- (90% C = 0.01%/1000 Hrs. conf.)
- Comm: Z = Non ER

+ = Surge Option:

- For TAZ p/n:
- 00 = None
- 23 = 10 cycles, +25°C
- 24 = 10 cycles, -55°C & +85°C

- For CWR p/n:
- A = 10 cycles, +25°C
- B = 10 cycles, -55°C & +85°C

□ = Packaging:

- For TAZ p/n:
- B = Bulk
- R = 7" T&R
- S = 13" T&R
- For CWR p/n:
- Bulk = Standard
- \TR = 7" T&R
- \TR13 = 13" T&R
- \W = Waffle



Surface Mount Military



CWR09 - MIL-PRF-55365/04 and TAZ COTS-Plus

AVX Part Number	QPL Part Number (for reference only)	DC rated voltage (85°C) (volts)	Cap (nom) µF	DC Leakage (max)			Dissipation Factor (max)			ESR (max) 100 kHz +25°C (Ohms)	Case Size
				+25°C (µA)	+85°C (µA)	+125°C (µA)	+25°C (%)	+85/125°C (%)	-55°C (%)		
TAZA334*025C□#@0^++	CWR09K^334*@+□	25	0.33	1.0	10	12	6	8	8	15.0	A
TAZA474*025C□#@0^++	CWR19K^474*@+□	25	0.47	0.1175	1.175	1.41	6	8	8	15	A
TAZB684*025C□#@0^++	CWR09K^684*@+□	25	0.68	1.0	10	12	6	8	8	7.5	B
TAZB105*025C□#@0^++	CWR19K^105*@+□	25	1.0	1.0	10	12	6	8	8	10.0	B
TAZD155*025C□#@0^++	CWR09K^155*@+□	25	1.5	1.0	10	12	6	8	8	6.5	D
TAZD225*025C□#@0^++	CWR19K^225*@+□	25	2.2	1.0	10	12	6	8	8	6.0	D
TAZE225*025C□#@0^++	CWR09K^225*@+□	25	2.2	1.0	10	12	6	8	8	3.5	E
TAZE335*025C□#@0^++	CWR19K^335*@+□	25	3.3	1.0	10	12	6	8	8	4.0	E
TAZF475*025C□#@0^++	CWR09K^475*@+□	25	4.7	2.0	20	24	6	8	8	2.5	F
TAZF685*025C□#@0^++	CWR19K^685*@+□	25	6.8	2.0	20	24	6	8	8	3.0	F
TAZG685*025C□#@0^++	CWR09K^685*@+□	25	6.8	2.0	20	24	6	8	8	1.2	G
TAZG106*025C□#@0^++	CWR09K^106*@+□	25	10.0	3.0	30	36	6	8	8	1.4	G
TAZG156*025C□#@0^++	CWR19K^156*@+□	25	15	3.75	37.5	45	6	8	8	1.4	G
TAZH156*025C□#@0^++	CWR09K^156*@+□	25	15.0	4.0	40	48	6	8	8	1.0	H
TAZG226*025C□#@0^++	CWR19K^226*@+□	25	22	5.5	55	66	6	8	8	1.4	G
TAZH226*025C□#@0^++	CWR19K^226*@+□	25	22.0	6.0	60	72	6	8	8	0.9	H
TAZH226*025L□#@0^++	CWR29K^226*@+□	25	22.0	6.0	60	72	6	8	8	0.200	H
TAZH336*025C□#@0^++	CWR19K^336*@+□	25	33	8.25	82.5	99	8	10	12	0.9	H
TAZV686(*)025L□#@00++		25	68.0	17.0	170	340	8	10	12	0.150	V
TAZA224*035C□#@0^++	CWR09M^224*@+□	35	0.22	1.0	10	12	6	8	8	18.0	A
TAZA334*035C□#@0^++	CWR19M^334*@+□	35	0.33	0.1155	1.155	1.386	6	8	8	22	A
TAZB474*035C□#@0^++	CWR09M^474*@+□	35	0.47	1.0	10	12	6	8	8	10.0	B
TAZD105*035C□#@0^++	CWR09M^105*@+□	35	1.0	1.0	10	12	6	8	8	6.5	D
TAZE155*035C□#@0^++	CWR09M^155*@+□	35	1.5	1.0	10	12	6	8	8	4.5	E
TAZF335*035C□#@0^++	CWR09M^335*@+□	35	3.3	1.0	10	12	6	8	8	2.5	F
TAZG475*035C□#@0^++	CWR09M^475*@+□	35	4.7	2.0	20	24	6	8	8	1.5	G
TAZH685*035C□#@0^++	CWR09M^685*@+□	35	6.8	3.0	30	36	6	8	8	1.3	H
TAZH106*035C□#@0^++	CWR19M^106*@+□	35	10.0	4.0	40	48	8	10	10	0.9	H
TAZH106*035L□#@0^++	CWR29M^106*@+□	35	10.0	4.0	40	48	8	10	10	0.300	H
TAZG686*035C□#@0^++		35	6.8	2.38	23.8	28.56	6	8	8	1.5	G
TAZA104*050C□#@0^++	CWR09N^104*@+□	50	0.10	1.0	10	12	6	8	8	22.0	A
TAZA154*050C□#@0^++	CWR09N^154*@+□	50	0.15	1.0	10	12	6	8	8	17.0	A
TAZB224*050C□#@0^++	CWR09N^224*@+□	50	0.22	1.0	10	12	6	8	8	14.0	B
TAZB334*050C□#@0^++	CWR09N^334*@+□	50	0.33	1.0	10	12	6	8	8	12.0	B
TAZD684*050C□#@0^++	CWR09N^684*@+□	50	0.68	1.0	10	12	6	8	8	7.0	D
TAZE105*050C□#@0^++	CWR09N^105*@+□	50	1.0	1.0	10	12	6	8	8	6.0	E
TAZF155*050C□#@0^++	CWR09N^155*@+□	50	1.5	1.0	10	12	6	8	8	4.0	F
TAZF225*050C□#@0^++	CWR09N^225*@+□	50	2.2	2.0	20	24	6	8	8	2.5	F
TAZG335*050C□#@0^++	CWR09N^335*@+□	50	3.3	2.0	20	24	6	8	8	2.0	G
TAZH475*050C□#@0^++	CWR09N^475*@+□	50	4.7	3.0	30	36	6	8	8	1.5	H

Following the voltage code, C designates Standard, L designates Low ESR Ratings

CWR19, CWR29 DESIGNATIONS ARE INCLUDED FOR REFERENCE ONLY – USE TAZ P/N TO ORDER

Part Number Designations

^ = Termination Finish:1

For TAZ p/n:

9 = Gold Plated

8 = Hot Solder Dipped

0 = Solder Fused

For CWR p/n:

B = Gold Plated

C = Hot Solder Dipped

K = Solder Fused

= Inspection Level:

S = Std. Conformance

L = Optional Group A

For CWR p/n:

M = Military

Conformance per

MIL-PRF-55365

* = Tolerance:

M = ±20%

K = ±10%

J = ±5% (Special order only)

@ = Failure Rate Level:

Weibull: B = 0.1%/1000 Hrs.

(90% C = 0.01%/1000 Hrs.

conf.)

Comm: Z = Non ER

+ = Surge Option:

For TAZ p/n:

00 = None

23 = 10 cycles, +25°C

24 = 10 cycles,

-55°C & +85°C

For CWR p/n:

A = 10 cycles, +25°C

B = 10 cycles,

-55°C & +85°C

□ = Packaging:

For TAZ p/n:

B = Bulk

R = 7" T&R

S = 13" T&R

For CWR p/n:

Bulk = Standard

\TR = 7" T&R

\TR13 = 13" T&R

\W = Waffle



TBJ Series



Including CWR11 and COTS-Plus



The TBJ Series encompasses five case sizes, A through E, corresponding to EIA-535BAAC, the commercial industry standard. This series also offers molded body/compliant termination construction, polarity and capacitance marking. The molded construction is compatible with a wide range of SMT board assembly processes including wave or reflow

solder, conductive epoxy or compression bonding techniques. Standard termination finish is fused solder. Gold termination is optional on CWR11 ratings. Case sizes A through D include QPL ratings available to the CWR11 military part number; other extended range and Low ESR ratings are available in all case sizes.

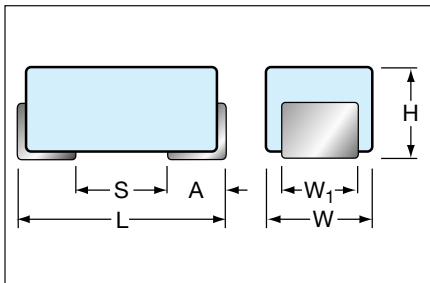

CASE DIMENSIONS: millimeters (inches)

Case Code	EIA Code	Length (L)	Width (W)	Height (H)	Term. Width (W ₁) ±0.10 (±0.004)	Term. Length A ±0.30(±0.012)	S min
A	3216-18	3.20±0.20 (0.126±0.008)	1.60±0.20 (0.063±0.008)	1.60±0.20 (0.063±0.008)	1.20 (0.047)	0.80 (0.031)	0.80 (0.031)
B	3528-21	3.50±0.20 (0.138±0.008)	2.80±0.20 (0.110±0.008)	1.90±0.20 (0.075±0.008)	2.20 (0.087)	0.80 (0.031)	1.10 (0.043)
C	6032-28	6.00±0.30 (0.236±0.012)	3.20±0.30 (0.126±0.012)	2.50±0.30 (0.098±0.012)	2.20 (0.087)	1.30 (0.051)	2.50 (0.098)
D	7343-31	7.30±0.30 (0.287±0.012)	4.30±0.30 (0.169±0.012)	2.80±0.30 (0.110±0.012)	2.40 (0.094)	1.30 (0.051)	3.80 (0.150)
E	7343-43	7.30±0.30 (0.287±0.012)	4.30±0.30 (0.169±0.012)	4.10±0.30 (0.162±0.012)	2.40 (0.094)	1.30 (0.051)	3.80 (0.150)

MILITARY MARKING

(Brown marking on gold body)



Polarity Stripe (+)
"J" for "JAN" Brand
Capacitance Code
Rated Voltage
Manufacturer's ID

"COTS - Plus" MARKING

(Brown marking on gold body)



Polarity Stripe (+)
Capacitance Code
Rated Voltage
Manufacturer's ID
Lot Number

Technical Data:	Unless otherwise specified, all technical data relate to an ambient temperature of 25°C									
Capacitance Range:	0.1 to 470 µF									
Capacitance Tolerance:	±20%, ±10%, ±5%									
Rated DC Voltage: (V _R)	≤85°C:	4	6	10	15	20	25	35	50	
Category Voltage: (V _C)	125°C:	2.7	4	7	10	13	17	23	33	
Surge Voltage: (V _C)	≤85°C:	5.2	8	13	20	26	33	46	65	
	125°C:	3.5	5	9	12	16	21	28	40	
Operating Temperature Range:	-55°C to +125°C									

CWR11 - MIL-PRF-55365/08

Fully qualified to MIL-PRF-55365/08, the CWR11 is the military version of EIA-535BAAC, the commercial industry standard. It comprises four case sizes (A through D). This series also offers molded body/compliant termination construction, polarity, capacitance and JAN brand marking. The molded construction is compatible with a wide range of

SMT board assembly processes including wave or reflow solder, conductive epoxy or compression bonding techniques. There are three termination finishes available: fused solder plated ("K" per MIL-PRF-55365), hot solder dipped ("C") and gold plated ("B").

PART NUMBERING SYSTEM

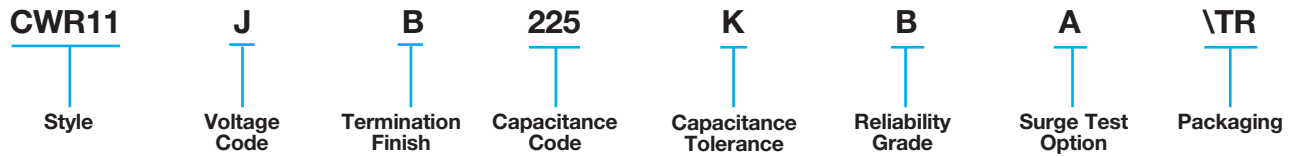

TBJ COTS-Plus SERIES

This series features:

- CWR11 form factor in Standard and Extended ratings.
- Low ESR Ratings (Cases A through E).
- Extended Case size (E) for ratings to 470 μ F.
- Weibull Reliability Grading and Surge Test options.

All ratings in this series offer the advantages of molded body/compliant termination construction, polarity, capacitance and voltage marking. The molded construction is compatible with a wide range of SMT board assembly processes including wave or reflow solder, conductive epoxy or compression bonding techniques.

PART NUMBERING SYSTEM

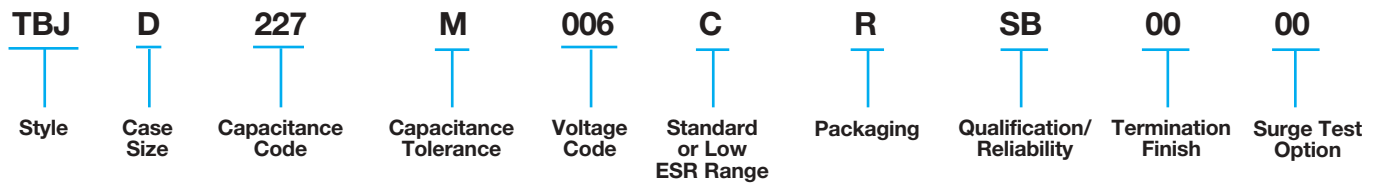

Surface Mount Military



CWR11 - MIL-PRF-55365/08 and TBJ COTS-Plus

AVX Part Number	QPL Part Number (for reference only)	DC rated voltage (85°C) (volts)	Cap (nom) µF	DC Leakage (max)			Dissipation Factor (max)			ESR (max) 100 kHz +25°C (Ohms)	Case Size
				+25°C (µA)	+85°C (µA)	+125°C (µA)	+25°C (%)	+85/125°C (%)	-55°C (%)		
TBJA225(*)004C□#@00++		4	2.2	0.5	5.0	10.0	6	9	9	8.0	A
TBJA475(*)004C□#@00++		4	4.7	0.5	5.0	10.0	6	9	9	8.0	A
TBJA685(*)004C□#@00++		4	6.8	0.5	5.0	10.0	6	9	10	6.5	A
TBJB685(*)004C□#@00++		4	6.8	0.5	5.0	10.0	6	9	9	5.5	B
TBJA106(*)004C□#@00++		4	10.0	0.5	5.0	10.0	6	9	10	6.0	A
TBJB106(*)004C□#@00++		4	10.0	0.5	5.0	10.0	6	9	9	4.0	B
TBJA156(*)004C□#@00++		4	15.0	0.6	6.0	12.0	6	9	10	4.0	A
TBJB156(*)004C□#@00++		4	15.0	0.6	6.0	12.0	6	9	9	3.5	B
TBJA226(*)004C□#@00++		4	22.0	0.9	9.0	18.0	6	9	10	3.5	A
TBJA336(*)004C□#@00++		4	33.0	1.4	14.0	28.0	6	9	9	3.0	A
TBJB336(*)004C□#@00++		4	33.0	1.4	14.0	28.0	6	9	10	2.8	B
TBJC336(*)004C□#@00++		4	33.0	1.3	13.0	26.0	6	9	9	2.2	C
TBJB476(*)004C□#@00++		4	47.0	1.9	19.0	38.0	6	9	10	2.4	B
TBJC686(*)004C□#@00++		4	68.0	2.7	27.0	54.0	6	9	10	1.6	C
TBJD686(*)004C□#@00++		4	68.0	2.7	27.0	54.0	6	9	9	1.1	D
TBJB107(*)004C□#@00++		4	100.0	4.0	40.0	80.0	8	10	12	1.6	B
TBJC107(*)004C□#@00++		4	100.0	4.0	40.0	80.0	6	9	10	1.3	C
TBJD227(*)004C□#@00++		4	220.0	8.8	88.0	176.0	8	10	12	0.9	D
TBJE337(*)004C□#@00++		4	330.0	13.2	132.0	264.0	8	10	12	0.9	E
TBJA155(*)006C□#@00++	CWR11DK155*@+□	6.3	1.5	0.5	5.0	6.0	6	9	9	8.0	A
TBJA225(*)006C□#@00++	CWR11DK225*@+□	6.3	2.2	0.5	5.0	6.0	6	9	9	8.0	A
TBJA335(*)006C□#@00++	CWR11DK335*@+□	6.3	3.3	0.5	5.0	6.0	6	9	9	8.0	A
TBJA475(*)006C□#@00++		6.3	4.7	0.5	5.0	10.0	6	9	10	6.0	A
TBJB475(*)006C□#@00++	CWR11DK475*@+□	6.3	4.7	0.5	5.0	6.0	6	9	9	5.5	B
TBJA685(*)006C□#@00++		6.3	6.8	0.5	5.0	10.0	6	9	10	5.0	A
TBJB685(*)006C□#@00++	CWR11DK685*@+□	6.3	6.8	0.5	5.0	6.0	6	9	9	4.5	B
TBJA106(*)006C□#@00++		6.3	10.0	1.0	10.0	20.0	6	9	10	4.0	A
TBJB106(*)006C□#@00++	CWR11DK106*@+□	6.3	10.0	1.0	10.0	12.0	6	9	9	3.5	B
TBJA156(*)006C□#@00++		6.3	15.0	1.0	10.0	20.0	6	9	10	3.5	A
TBJA156(*)006L□#@00++		6.3	15.0	1.0	10.0	20.0	6	9	10	1.5	A
TBJB156(*)006C□#@00++		6.3	15.0	1.0	10.0	20.0	6	9	10	3.5	B
TBJC156(*)006C□#@00++	CWR11DK156*@+□	6.3	15.0	1.0	10.0	12.0	6	9	9	3.0	C
TBJA226(*)006C□#@00++		6.3	22.0	1.4	14.0	28.0	6	9	10	3.0	A
TBJB226(*)006C□#@00++		6.3	22.0	1.4	14.0	28.0	6	9	10	2.5	B
TBJC226(*)006C□#@00++	CWR11DK226*@+□	6.3	22.0	1.4	14.0	16.8	6	9	9	2.2	C
TBJB336(*)006C□#@00++		6.3	33.0	2.1	21.0	42.0	6	9	10	2.2	B
TBJB336(*)006L□#@00++		6.3	33.0	2.1	21.0	42.0	6	9	10	0.600	B
TBJC336(*)006C□#@00++		6.3	33.0	2.1	21.0	42.0	6	9	10	1.8	C
TBJC476(*)006C□#@00++		6.3	47.0	3.0	30.0	60.0	6	9	10	1.6	C
TBJD476(*)006C□#@00++	CWR11DK476*@+□	6.3	47.0	3.0	30.0	36.0	6	9	9	1.1	D
TBJB686(*)006C□#@00++		6.3	68.0	4.3	43.0	86.0	8	10	12	1.8	B
TBJC686(*)006C□#@00++		6.3	68.0	4.3	43.0	86.0	6	9	10	1.6	C
TBJD686(*)006C□#@00++		6.3	68.0	4.3	43.0	86.0	6	9	10	0.9	D
TBJC107(*)006C□#@00++		6.3	100.0	6.3	63.0	126.0	6	9	10	0.9	C
TBJC107(*)006L□#@00++		6.3	100.0	6.3	63.0	126.0	6	9	10	0.150	C
TBJD107(*)006C□#@00++		6.3	100.0	6.3	63.0	126.0	6	9	10	0.9	D
TBJD157(*)006C□#@00++		6.3	150.0	9.5	95.0	190.0	6	9	10	0.9	D
TBJC227(*)006C□#@00++		6.3	220.0	13.9	139.0	278.0	10	12	14	1.2	C
TBJD227(*)006C□#@00++		6.3	220.0	13.9	139.0	278.0	8	10	12	0.9	D
TBJD227(*)006L□#@00++		6.3	220.0	13.9	139.0	278.0	8	10	12	0.100	D
TBJE337(*)006C□#@00++		6.3	330.0	19.8	198.0	396.0	8	10	12	0.9	E
TBJE337(*)006L□#@00++		6.3	330.0	20.8	208.0	416.0	8	10	12	0.100	E
TBJE477M006C□#@00++		6.3	470.0	29.6	296.0	592.0	10	12	14	0.9	E
TBJE477M006L□#@00++		6.3	470.0	29.6	296.0	592.0	10	12	14	0.050	E

Following the voltage code, C designates Standard, L Designates low ESR Ratings

Part Number Designations

*** = Tolerance:**

M = ±20%
K = ±10%
J = ±5% (Special order only)

= Inspection Level:

S = Std. Conformance
L = Optional Group A
For CWR p/n:
M = Military Conformance per MIL-PRF-55365

@ = Failure Rate Level:

Weibull: B = 0.1%/1000 Hrs.
(90% C = 0.01%/1000 Hrs.
conf.
Comm: Z = Non ER

+ = Surge Option:

For TBJ p/n:
00 = None
23 = 10 cycles, +25°C
24 = 10 cycles, -55°C & +85°C
For CWR p/n:
A = 10 cycles, +25°C
B = 10 cycles, -55°C & +85°C

□ = Packaging:

For TBJ p/n:
B = Bulk
R = 7" T&R
S = 13" T&R
For CWR p/n:
Bulk = Standard
VTR = 7" T&R
VTR13 = 13" T&R
W = Waffle



Surface Mount Military



CWR11 - MIL-PRF-55365/08 and TBJ COTS-Plus

AVX Part Number	QPL Part Number (for reference only)	DC rated voltage (85°C) (volts)	Cap (nom) µF	DC Leakage (max)			Dissipation Factor (max)			ESR (max) 100 kHz +25°C (Ohms)	Case Size
				+25°C (µA)	+85°C (µA)	+125°C (µA)	+25°C (%)	+85/125°C (%)	-55°C (%)		
TBJA105(*)010C□#@00++	CWR11FK105*@+□	10	1.0	0.5	5.0	6.0	4	6	6	10.0	A
TBJA155(*)010C□#@00++	CWR11FK155*@+□	10	1.5	0.5	5.0	6.0	6	9	9	8.0	A
TBJA225(*)010C□#@00++	CWR11FK225*@+□	10	2.2	0.5	5.0	6.0	6	9	9	8.0	A
TBJA335(*)010C□#@00++		10	3.3	0.5	5.0	10.0	6	9	10	5.5	A
TBJB335(*)010C□#@00++	CWR11FK335*@+□	10	3.3	0.5	5.0	6.0	6	9	9	5.5	B
TBJA475(*)010C□#@00++		10	4.7	0.5	5.0	10.0	6	9	10	5.0	A
TBJB475(*)010C□#@00++	CWR11FK475*@+□	10	4.7	0.5	5.0	6.0	6	9	9	4.5	B
TBJA685(*)010C□#@00++		10	6.8	0.7	7.0	14.0	6	9	10	4.0	A
TBJB685(*)010C□#@00++	CWR11FK685*@+□	10	6.8	0.7	7.0	8.4	6	9	9	3.5	B
TBJA106(*)010C□#@00++		10	10.0	1.0	10.0	20.0	6	9	10	3.0	A
TBJA106(*)010L□#@00++		10	10.0	1.0	10.0	20.0	6	9	10	1.8	A
TBJB106(*)010C□#@00++		10	10.0	1.0	10.0	20.0	6	9	10	2.5	B
TBJC106(*)010C□#@00++		10	10.0	1.0	10.0	20.0	6	9	10	2.5	C
TBJA156(*)010C□#@00++		10	15.0	1.6	16.0	32.0	6	9	10	3.2	A
TBJB156(*)010C□#@00++		10	15.0	1.6	16.0	32.0	6	9	10	2.8	B
TBJC156(*)010C□#@00++	CWR11FK156*@+□	10	15.0	1.5	15.0	18.0	6	9	9	2.5	C
TBJB226(*)010C□#@00++		10	22.0	2.2	22.0	44.0	6	9	10	2.4	B
TBJB226(*)010L□#@00++		10	22.0	2.2	22.0	44.0	6	9	10	0.700	B
TBJC226(*)010C□#@00++		10	22.0	2.2	22.0	44.0	6	9	10	1.0	C
TBJB336(*)010C□#@00++		10	33.0	3.3	33.0	66.0	6	9	10	1.8	B
TBJC336(*)010C□#@00++		10	33.0	3.3	33.0	66.0	6	9	10	1.6	C
TBJD336(*)010C□#@00++	CWR11FK336*@+□	10	33.0	3.3	33.0	39.6	6	9	9	1.1	D
TBJC476(*)010C□#@00++		10	47.0	4.7	47.0	94.0	6	9	10	1.2	C
TBJD476(*)010C□#@00++		10	47.0	4.7	47.0	94.0	6	9	10	0.9	D
TBJC686(*)010C□#@00++		10	68.0	6.8	68.0	136.0	8	10	12	1.2	C
TBJD686(*)010C□#@00++		10	68.0	6.8	68.0	136.0	6	9	10	0.9	D
TBJC107(*)010C□#@00++		10	100.0	10.0	100.0	200.0	8	10	12	1.2	C
TBJC107(*)010L□#@00++		10	100.0	10.0	100.0	200.0	8	10	12	0.200	C
TBJD107(*)010C□#@00++		10	100.0	10.0	100.0	200.0	6	9	10	0.9	D
TBJD107(*)010L□#@00++		10	100.0	10.0	100.0	200.0	6	9	10	0.100	D
TBJD157(*)010C□#@00++		10	150.0	15.0	150.0	300.0	8	10	12	0.9	D
TBJD157(*)010L□#@00++		10	150.0	15.0	150.0	300.0	8	10	12	0.100	D
TBJD227M010C□#@00++		10	220.0	22.0	220.0	440.0	8	10	12	0.9	D
TBJD227M010L□#@00++		10	220.0	22.0	220.0	440.0	8	10	12	0.150	D
TBJE227(*)010C□#@00++		10	220.0	22.0	220.0	440.0	8	10	12	0.9	E
TBJE227(*)010L□#@00++		10	220.0	22.0	220.0	440.0	8	10	12	0.100	E
TBJD337M010C□#@00++		10	330.0	33.0	330.0	660.0	8	10	12	0.9	D
TBJD337M010L□#@00++		10	330.0	33.0	330.0	660.0	8	10	12	0.150	D
TBJE337(*)010C□#@00++		10	330.0	33.0	330.0	660.0	8	10	12	0.9	E
TBJE337(*)010L□#@00++		10	330.0	33.0	330.0	660.0	8	10	12	0.060	E
TBJE477M010C□#@00++		10	470.0	47.0	470.0	940.0	10	12	14	0.9	E
TBJE477M010L□#@00++		10	470.0	47.0	470.0	940.0	10	12	14	0.050	E

Following the voltage code, C designates Standard, L designates Low ESR Ratings

Part Number Designations

*** = Tolerance:**

M = ±20%
K = ±10%
J = ±5% (Special order only)

= Inspection Level:

S = Std. Conformance
L = Optional Group A
For CWR p/n:
M = Military Conformance per
MIL-PRF-55365

@ = Failure Rate Level:

Weibull: B = 0.1%/1000 Hrs.
(90% C = 0.01%/1000 Hrs.
conf.)
Comm: Z = Non ER

+ = Surge Option:

For TBJ p/n:
00 = None
23 = 10 cycles, +25°C
24 = 10 cycles, -55°C & +85°C
For CWR p/n:
A = 10 cycles, +25°C
B = 10 cycles, -55°C & +85°C

□ = Packaging:

For TBJ p/n:
B = Bulk
R = 7" T&R
S = 13" T&R
For CWR p/n:
Bulk = Standard
VTR = 7" T&R
VTR13 = 13" T&R
W = Waffle



Surface Mount Military



CWR11 - MIL-PRF-55365/08 and TBJ COTS-Plus

AVX Part Number	QPL Part Number (for reference only)	DC rated voltage (85°C) (volts)	Cap (nom) µF	DC Leakage (max)			Dissipation Factor (max)			ESR (max) 100 kHz +25°C (Ohms)	Case Size
				+25°C (µA)	+85°C (µA)	+125°C (µA)	+25°C (%)	+85/125°C (%)	-55°C (%)		
TBJA684(*)016C□#@00++	CWR11HK684*+□	16	0.68	0.5	5.0	6.0	4	6	6	12.0	A
TBJA105(*)016C□#@00++	CWR11HK105*+□	16	1.0	0.5	5.0	6.0	4	6	6	10.0	A
TBJA155(*)016C□#@00++	CWR11HK155*+□	16	1.5	0.5	5.0	6.0	6	9	9	8.0	A
TBJA225(*)016C□#@00++		16	2.2	0.5	5.0	10.0	6	9	10	5.5	A
TBJB225(*)016C□#@00++	CWR11HK225*+□	16	2.2	0.5	5.0	6.0	6	9	9	5.0	B
TBJA335(*)016C□#@00++		16	3.3	0.5	5.0	10.0	6	9	10	5.0	A
TBJA335(*)016L□#@00++		16	3.3	0.5	5.0	10.0	6	9	10	3.5	A
TBJB335(*)016C□#@00++	CWR11HK335*+□	16	3.3	0.5	5.0	6.0	6	8	9	5.0	B
TBJA475(*)016C□#@00++		16	4.7	0.8	8.0	16.0	6	9	10	4.0	A
TBJB475(*)016C□#@00++	CWR11HK475*+□	16	4.7	0.8	8.0	9.6	6	9	9	4.0	B
TBJA685(*)016C□#@00++		16	6.8	1.1	11.0	22.0	6	9	10	2.5	A
TBJB685(*)016C□#@00++		16	6.8	1.1	11.0	22.0	6	9	10	2.5	B
TBJC685(*)016C□#@00++		16	6.8	1.1	11.0	22.0	6	9	10	2.5	C
TBJB106(*)016C□#@00++		16	10.0	1.6	16.0	32.0	6	9	10	2.8	B
TBJC106(*)016C□#@00++	CWR11HK106*+□	16	10.0	1.6	16.0	19.2	6	8	9	2.5	C
TBJB156(*)016C□#@00++		16	15.0	2.4	24.0	48.0	6	9	10	2.5	B
TBJB156(*)016L□#@00++		16	15.0	2.4	24.0	48.0	6	9	10	0.800	B
TBJC156(*)016C□#@00++		16	15.0	2.4	24.0	48.0	6	9	10	1.8	C
TBJB226(*)016C□#@00++		16	22.0	3.6	36.0	72.0	6	9	10	2.3	B
TBJC226(*)016C□#@00++		16	22.0	3.6	36.0	72.0	6	9	10	1.6	C
TBJC226(*)016L□#@00++		16	22.0	3.6	36.0	72.0	6	9	10	0.375	C
TBJD226(*)016C□#@00++	CWR11HK226*+□	16	22.0	3.6	36.0	43.2	6	8	9	1.1	D
TBJC336(*)016C□#@00++		16	33.0	5.3	53.0	106.0	6	9	10	1.5	C
TBJC336(*)016L□#@00++		16	33.0	5.3	53.0	106.0	6	9	10	0.300	C
TBJD336(*)016C□#@00++		16	33.0	5.3	53.0	106.0	6	9	10	0.9	D
TBJC476(*)016C□#@00++		16	47.0	7.6	76.0	152.0	6	9	10	1.5	C
TBJC476(*)016L□#@00++		16	47.0	7.6	76.0	152.0	6	9	10	0.350	C
TBJD476(*)016C□#@00++		16	47.0	7.6	76.0	152.0	6	9	10	0.9	D
TBJD476(*)016L□#@00++		16	47.0	7.6	76.0	152.0	6	9	10	0.150	D
TBJD686(*)016C□#@00++		16	68.0	10.9	109.0	218.0	6	9	10	0.9	D
TBJD107(*)016C□#@00++		16	100.0	16.0	160.0	320.0	6	9	10	0.9	D
TBJD107(*)016L□#@00++		16	100.0	16.0	160.0	320.0	6	9	10	0.125	D
TBJE107(*)016C□#@00++		16	100.0	16.0	160.0	320.0	6	9	10	0.9	E
TBJE107(*)016L□#@00++		16	100.0	16.0	160.0	320.0	6	9	10	0.100	E
TBJD157M016C□#@00++		16	150.0	24.0	240.0	480.0	6	9	10	0.9	D
TBJD157M016L□#@00++		16	150.0	24.0	240.0	480.0	6	9	10	0.150	D

Following the voltage code, C designates Standard, L designates Low ESR Ratings

Part Number Designations

*** = Tolerance:**

M = ±20%
K = ±10%
J = ±5% (Special order only)

= Inspection Level:

S = Std. Conformance
L = Optional Group A
For CWR p/n:
M = Military Conformance per MIL-PRF-55365

@ = Failure Rate Level:

Weibull: B = 0.1%/1000 Hrs.
(90% C = 0.01%/1000 Hrs. conf.)
Comm: Z = Non ER

+ = Surge Option:

For TBJ p/n:
00 = None
23 = 10 cycles, +25°C
24 = 10 cycles, -55°C & +85°C
For CWR p/n:
A = 10 cycles, +25°C
B = 10 cycles, -55°C & +85°C

□ = Packaging:

For TBJ p/n:
B = Bulk
R = 7" T&R
S = 13" T&R
For CWR p/n:
Bulk = Standard
\TR = 7" T&R
\TR13 = 13" T&R
W = Waffle



Surface Mount Military



CWR11 - MIL-PRF-55365/08 and TBJ COTS-Plus

AVX Part Number	QPL Part Number (for reference only)	DC rated voltage (85°C) (volts)	Cap (nom) µF	DC Leakage (max)			Dissipation Factor (max)			ESR (max) 100 kHz +25°C (Ohms)	Case Size
				+25°C (µA)	+85°C (µA)	+125°C (µA)	+25°C (%)	+85/125°C (%)	-55°C (%)		
TBJA474(*)020C□#@00++	CWR11JK474*@+□	20	0.47	0.5	5.0	6.0	4	6	6	14.0	A
TBJA684(*)020C□#@00++	CWR11JK684*@+□	20	0.68	0.5	5.0	6.0	4	6	6	12.0	A
TBJA105(*)020C□#@00++	CWR11JK105*@+□	20	1.0	0.5	5.0	6.0	4	6	6	10.0	A
TBJA155(*)020C□#@00++		20	1.5	0.5	5.0	10.0	6	8	10	6.5	A
TBJB155(*)020C□#@00++	CWR11JK155*@+□	20	1.5	0.5	5.0	6.0	6	9	9	6.0	B
TBJB225(*)020C□#@00++	CWR11JK225*@+□	20	2.2	0.5	5.0	6.0	6	8	9	5.0	B
TBJB335(*)020C□#@00++	CWR11JK335*@+□	20	3.3	1.0	10.0	20.0	6	9	9	4.0	B
TBJA475(*)020C□#@00++		20	4.7	1.0	10.0	20.0	6	8	10	4.0	A
TBJA475(*)020L□#@00++		20	4.7	1.0	10.0	20.0	6	8	10	1.8	A
TBJB475(*)020C□#@00++		20	4.7	2.0	20.0	40.0	6	8	10	3.0	B
TBJC475(*)020C□#@00++	CWR11JK475*@+□	20	4.7	1.0	10.0	12.0	6	8	9	3.0	C
TBJB685(*)020C□#@00++		20	6.8	1.4	14.0	28.0	6	8	10	2.5	B
TBJC685(*)020C□#@00++	CWR11JK685*@+□	20	6.8	1.4	14.0	16.8	6	9	9	2.4	C
TBJB106(*)020C□#@00++		20	10.0	0.7	7.0	14.0	6	8	10	2.1	B
TBJB106(*)020L□#@00++		20	10.0	0.7	7.0	14.0	6	8	10	1.0	B
TBJC106(*)020C□#@00++		20	10.0	1.4	14.0	28.0	6	8	10	1.9	C
TBJB156(*)020C□#@00++		20	15.0	3.0	30.0	60.0	6	8	10	2.0	B
TBJC156(*)020C□#@00++		20	15.0	3.0	30.0	60.0	6	8	10	1.7	C
TBJD156(*)020C□#@00++	CWR11JK156*@+□	20	15.0	3.0	30.0	36.0	6	8	9	1.1	D
TBJC226(*)020C□#@00++		20	22.0	4.4	44.0	88.0	6	8	10	1.6	C
TBJD226(*)020C□#@00++		20	22.0	4.4	44.0	88.0	6	8	10	0.9	D
TBJC336(*)020C□#@00++		20	33.0	6.6	66.0	132.0	6	8	10	1.5	C
TBJD336(*)020C□#@00++		20	33.0	6.6	66.0	132.0	6	8	10	0.9	D
TBJD336(*)020L□#@00++		20	33.0	6.6	66.0	132.0	6	8	10	0.200	D
TBJD476(*)020C□#@00++		20	47.0	9.4	94.0	188.0	6	8	10	0.9	D
TBJD686(*)020C□#@00++		20	68.0	13.6	136.0	272.0	6	8	10	0.9	D
TBJE686(*)020C□#@00++		20	68.0	13.6	136.0	272.0	6	8	10	0.9	E
TBJE686(*)020L□#@00++		20	68.0	13.6	136.0	272.0	6	8	10	0.150	E
TBJA334(*)025C□#@00++	CWR11KK334*@+□	25	0.33	0.5	5.0	6.0	4	6	6	15.0	A
TBJA474(*)025C□#@00++	CWR11KK474*@+□	25	0.47	0.5	5.0	6.0	4	6	6	14.0	A
TBJA684M025C□#@00++		25	0.68	0.5	5.0	10.0	4	6	8	10.0	A
TBJB684(*)025C□#@00++	CWR11KK684*@+□	25	0.68	0.5	5.0	6.0	4	6	6	7.5	B
TBJA105(*)025C□#@00++		25	1.0	0.5	5.0	10.0	4	6	8	8.0	A
TBJB105(*)025C□#@00++	CWR11KK105*@+□	25	1.0	0.5	5.0	6.0	4	6	6	6.5	B
TBJA155(*)025C□#@00++		25	1.5	0.5	5.0	10.0	6	8	10	7.5	A
TBJA155(*)025L□#@00++		25	1.5	0.5	5.0	10.0	6	8	10	3.0	A
TBJB155(*)025C□#@00++	CWR11KK155*@+□	25	1.5	0.5	5.0	6.0	6	8	9	6.5	B
TBJA225(*)025C□#@00++		25	2.2	0.5	5.0	10.0	6	8	10	7.0	A
TBJB225(*)025C□#@00++		25	2.2	0.5	5.0	10.0	6	8	10	4.5	B
TBJC225(*)025C□#@00++	CWR11KK225*@+□	25	2.2	0.6	6.0	7.2	6	9	9	3.5	C
TBJB335(*)025C□#@00++		25	3.3	0.5	5.0	10.0	6	8	10	3.5	B
TBJC335(*)025C□#@00++	CWR11KK335*@+□	25	3.3	0.9	9.0	10.8	6	8	9	3.5	C
TBJB475(*)025C□#@00++		25	4.7	1.2	12.0	24.0	6	8	10	2.8	B
TBJB475(*)025L□#@00++		25	4.7	1.2	12.0	24.0	6	8	10	1.5	B
TBJC475(*)025C□#@00++	CWR11KK475*@+□	25	4.7	1.2	12.0	14.4	6	9	9	2.5	C
TBJB685(*)025C□#@00++		25	6.8	1.7	17.0	34.0	6	8	10	2.8	B
TBJC685(*)025C□#@00++		25	6.8	1.7	17.0	34.0	6	8	10	2.0	C
TBJD685(*)025C□#@00++	CWR11KK685*@+□	25	6.8	1.7	17.0	20.4	6	9	9	1.4	D
TBJC106(*)025C□#@00++		25	10.0	2.5	25.0	50.0	6	8	10	1.8	C
TBJC106(*)025L□#@00++		25	10.0	2.5	25.0	50.0	6	8	10	0.500	C
TBJD106(*)025C□#@00++	CWR11KK106*@+□	25	10.0	2.5	25.0	30.0	6	8	9	1.2	D
TBJD156(*)025C□#@00++		25	15.0	3.8	38.0	76.0	8	9	9	1.0	D
TBJC226(*)025C□#@00++		25	22.0	5.5	55.0	110.0	6	8	10	1.4	C
TBJD226(*)025C□#@00++		25	22.0	5.5	55.0	110.0	6	8	10	0.9	D
TBJD226(*)025L□#@00++		25	22.0	5.5	55.0	110.0	6	8	10	0.200	D
TBJD336(*)025C□#@00++		25	33.0	8.3	83.0	166.0	6	8	10	0.9	D
TBJE336(*)025C□#@00++		25	33.0	8.3	83.0	166.0	6	8	10	0.9	E
TBJE336(*)025L□#@00++		25	33.0	8.3	83.0	166.0	6	8	10	0.300	E
TBJD476M025C□#@00++		25	47.0	11.8	118.0	236.0	6	8	10	0.9	D
TBJD476M025L□#@00++		25	47.0	11.8	118.0	236.0	6	8	10	0.250	D

Following the voltage code, C designates Standard, L Designates low ESR Ratings

Part Number Designations

*** = Tolerance:**

M = ±20%
K = ±10%
J = ±5% (Special order only)

= Inspection Level:

S = Std. Conformance
L = Optional Group A
For CWR p/n:
M = Military Conformance per MIL-PRF-55365

@ = Failure Rate Level:

Weibull: B = 0.1%/1000 Hrs.
(90% C = 0.01%/1000 Hrs.
conf.
Comm: Z = Non ER

+ = Surge Option:

For TBJ p/n:
00 = None
23 = 10 cycles, +25°C
24 = 10 cycles, -55°C & +85°C
For CWR p/n:
A = 10 cycles, +25°C
B = 10 cycles, -55°C & +85°C

□ = Packaging:

For TBJ p/n:
B = Bulk
R = 7" T&R
S = 13" T&R
For CWR p/n:
Bulk = Standard
\TR = 7" T&R
\TR13 = 13" T&R
\W = Waffle



Surface Mount Military



CWR11 - MIL-PRF-55365/08 and TBJ COTS-Plus

AVX Part Number	QPL Part Number (for reference only)	DC rated voltage (85°C) (volts)	Cap (nom) µF	DC Leakage (max)			Dissipation Factor (max)			ESR (max) 100 kHz +25°C (Ohms)	Case Size
				+25°C (µA)	+85°C (µA)	+125°C (µA)	+25°C (%)	+85/125°C (%)	-55°C (%)		
TBJA104(*)035C□#@00++	CWR11MK104*@+□	35	0.1	0.5	5.0	6.0	4	6	6	24.0	A
TBJA154(*)035C□#@00++	CWR11MK154*@+□	35	0.15	0.5	5.0	6.0	4	6	6	21.0	A
TBJA224(*)035C□#@00++	CWR11MK224*@+□	35	0.22	0.5	5.0	6.0	4	6	6	18.0	A
TBJA334(*)035C□#@00++	CWR11MK334*@+□	35	0.33	0.5	5.0	6.0	4	6	6	15.0	A
TBJA474M035C□#@00++		35	0.47	0.5	5.0	10.0	4	6	8	12.0	A
TBJB474(*)035C□#@00++	CWR11MK474*@+□	35	0.47	0.5	5.0	6.0	4	6	6	10.0	B
TBJA684M035C□#@00++		35	0.68	0.5	5.0	10.0	4	6	8	8.0	A
TBJB684(*)035C□#@00++	CWR11MK684*@+□	35	0.68	0.5	5.0	6.0	4	6	6	8.0	B
TBJA105(*)035C□#@00++		35	1.00	0.5	5.0	10.0	4	6	6	7.5	A
TBJB105(*)035C□#@00++	CWR11MK105*@+□	35	1.0	0.5	5.0	6.0	4	6	6	6.5	B
TBJA155(*)035C□#@00++		35	1.5	0.5	5.0	10.0	6	8	9	7.5	A
TBJB155(*)035C□#@00++		35	1.5	0.5	5.0	10.0	6	8	9	5.2	B
TBJC155(*)035C□#@00++	CWR11MK155*@+□	35	1.5	0.5	5.0	6.0	6	8	9	4.5	C
TBJB225(*)035C□#@00++		35	2.2	0.8	8.0	16.0	6	8	9	4.2	B
TBJC225(*)035C□#@00++	CWR11MK225*@+□	35	2.2	0.8	8.0	9.6	6	8	9	3.5	C
TBJB335(*)035C□#@00++		35	3.3	1.2	12.0	24.0	6	8	9	3.5	B
TBJC335(*)035C□#@00++	CWR11MK335*@+□	35	3.3	1.2	12.0	14.4	6	8	9	2.5	C
TBJB475(*)035C□#@00++		35	4.7	1.6	16.0	32.0	6	8	9	3.1	B
TBJC475(*)035C□#@00++		35	4.7	1.6	16.0	32.0	6	8	9	2.2	C
TBJC475(*)035L□#@00++		35	4.7	1.6	16.0	32.0	6	8	9	0.600	C
TBJD475(*)035C□#@00++	CWR11MK475*@+□	35	4.7	1.6	16.0	19.2	6	8	9	1.5	D
TBJC685(*)035C□#@00++		35	6.8	2.4	24.0	48.0	6	9	9	1.8	C
TBJD685(*)035C□#@00++		35	6.8	2.4	24.0	48.0	6	9	9	1.3	D
TBJC106(*)035C□#@00++		35	10.0	3.5	35.0	70.0	6	9	9	1.6	C
TBJD106(*)035C□#@00++		35	10.0	3.5	35.0	70.0	6	9	9	1.0	D
TBJD106(*)035L□#@00++		35	10.0	3.5	35.0	70.0	6	9	9	0.300	D
TBJC156(*)035C□#@00++		35	15.0	5.3	53.0	106.0	6	9	9	1.4	C
TBJD156(*)035C□#@00++		35	15.0	5.3	53.0	106.0	6	9	9	0.9	D
TBJD156(*)035L□#@00++		35	15.0	5.3	53.0	106.0	6	9	9	0.300	D
TBJD226(*)035C□#@00++		35	22.0	7.7	77.0	154.0	6	9	9	0.9	D
TBJD226(*)035L□#@00++		35	22.0	7.7	77.0	154.0	6	9	9	0.400	D
TBJE226(*)035C□#@00++		35	22.0	7.7	77.0	154.0	6	9	9	0.9	E
TBJE226(*)035L□#@00++		35	22.0	7.7	77.0	154.0	6	9	9	0.300	E
TBJD336M035C□#@00++		35	33.0	11.6	116.0	232.0	6	9	9	0.9	D
TBJD336M035L□#@00++		35	33.0	11.6	116.0	232.0	6	9	9	0.300	D
TBJA104(*)050C□#@00++	CWR11NK104*@+□	50	0.10	0.5	5.0	6.0	4	6	6	22.0	A
TBJA154M050C□#@00++		50	0.15	0.5	5.0	10.0	4	6	6	21.0	A
TBJB154(*)050C□#@00++	CWR11NK154*@+□	50	0.15	0.5	5.0	6.0	4	6	6	17.0	B
TBJA224M050C□#@00++		50	0.22	0.5	5.0	10.0	4	6	6	18.0	A
TBJB224(*)050C□#@00++	CWR11NK224*@+□	50	0.22	0.5	5.0	6.0	4	6	6	14.0	B
TBJB334(*)050C□#@00++	CWR11NK334*@+□	50	0.33	0.5	5.0	6.0	4	6	6	12.0	B
TBJC474(*)050C□#@00++	CWR11NK474*@+□	50	0.47	0.5	5.0	6.0	4	6	6	8.0	C
TBJC684(*)050C□#@00++	CWR11NK684*@+□	50	0.68	0.5	5.0	6.0	4	6	6	7.0	C
TBJC105(*)050C□#@00++	CWR11NK105*@+□	50	1.0	0.5	5.0	6.0	4	6	6	6.0	C
TBJC155(*)050C□#@00++		50	1.5	0.8	8.0	16.0	6	8	9	5.0	C
TBJD155(*)050C□#@00++	CWR11NK155*@+□	50	1.5	0.8	8.0	9.6	6	8	9	4.0	D
TBJD225(*)050C□#@00++	CWR11NK225*@+□	50	2.2	1.1	11.0	13.2	6	8	9	2.5	D
TBJD335(*)050C□#@00++		50	3.3	1.7	17.0	34.0	6	9	9	2.0	D
TBJD475(*)050C□#@00++		50	4.7	2.4	24.0	48.0	6	9	9	1.5	D
TBJD685(*)050C□#@00++		50	6.8	3.4	34.0	68.0	6	6	6	1.0	D

Following the voltage code, C designates Standard, L Designates low ESR Ratings

Part Number Designations

*** = Tolerance:**

M = ±20%
K = ±10%
J = ±5% (Special order only)

= Inspection Level:

S = Std. Conformance
L = Optional Group A
For CWR p/n:
M = Military Conformance per MIL-PRF-55365

@ = Failure Rate Level:

Weibull: B = 0.1%/1000 Hrs.
(90% C = 0.01%/1000 Hrs. conf.)
Comm: Z = Non ER

+ = Surge Option:

For TBJ p/n:
00 = None
23 = 10 cycles, +25°C
24 = 10 cycles, -55°C & +85°C
For CWR p/n:
A = 10 cycles, +25°C
B = 10 cycles, -55°C & +85°C

□ = Packaging:

For TBJ p/n:
B = Bulk
R = 7" T&R
S = 13" T&R
For CWR p/n:
Bulk = Standard
VTR = 7" T&R
VTR13 = 13" T&R
W = Waffle



Military Tantalum Capacitors



Tape and Reel Packaging

Solid Tantalum Chip TAZ Tape and reel packaging for automatic component placement.

Please enter required Suffix on order. Bulk packaging is standard.

TAZ TAPING SUFFIX TABLE

Case Size reference	Tape width mm	P mm	7" (180mm) reel		13" reel (330mm) reel	
			Suffix	Qty.	Suffix	Qty.
A	8	4	R	2500	S	9000
B	12	4	R	2500	S	9000
D	12	4	R	2500	S	8000
E	12	4	R	2500	S	8000
F	12	8	R	1000	S	3000
G	12	8	R	500	S	2500
H	12	8	R	500	S	2500

Total Tape Thickness — K max	
Case size reference	TAZ
	Millimeters (Inches) DIM
A	2.0 (0.079)
B	4.0 (0.157)
D	4.0 (0.157)
E	4.0 (0.157)
F	4.0 (0.157)
G	4.0 (0.157)
H	4.0 (0.157)

Code	8mm Tape		12mm Tape	
P*	4±0.1 or 8±0.1	(0.157±0.004) (0.315±0.004)	4±0.1 or 8±0.1	(0.157±0.004) (0.315±0.004)
G	0.75 min	(0.03 min)	0.75 min	(0.03 min)
F	3.5±0.05	(0.138±0.002)	5.5±0.05	(0.22±0.002)
E	1.75±0.1	(0.069±0.004)	1.75±0.1	(0.069±0.004)
W	8±0.3	(0.315±0.012)	12±0.3	(0.472±0.012)
P ₂	2±0.05	(0.079±0.002)	2±0.05	(0.079±0.002)
P ₀	4±0.1	(0.157±0.004)	4±0.1	(0.157±0.004)
D	1.5±0.1 -0	(0.059±0.004) (-0)	1.5±0.1 -0	(0.059±0.004) (-0)
D ₁	1.0 min	(0.039 min)	1.5 min	(0.059 min)

TAPE SPECIFICATION

Tape dimensions comply to EIA RS 481 A

Dimensions A₀ and B₀ of the pocket and the tape thickness, K, are dependent on the component size.

Tape materials do not affect component solderability during storage.

Carrier Tape Thickness <0.4mm

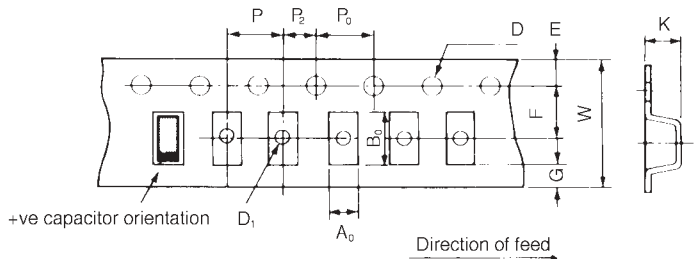

*See taping suffix tables for actual P dimension (component pitch).

PLASTIC TAPE REEL DIMENSIONS

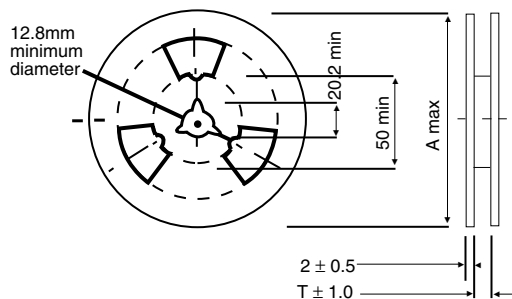

Standard Dimensions mm

A: 9.5mm (8mm tape)
13.0mm (12mm tape)

Cover Tape Dimensions

Thickness: 75±25µ
Width of tape:
5.5mm + 0.2mm (8mm tape)
9.5mm + 0.2mm (12mm tape)

Waffle Packaging - 2" x 2" hard plastic waffle trays. To order Waffle packaging use a "W" in part numbers packaging position.

Case Size	Maximum Quantity Per Waffle
TAZ A	160
TAZ B	112
TAZ D	88
TAZ E	60
TAZ F	48
TAZ G	50
TAZ H	28
CWR11 A	96
CWR11 B	72
CWR11 C	54
CWR11 D	28

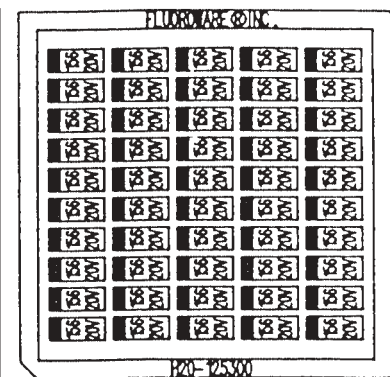

NOTE: Orientation of parts in waffle packs varies by case size.

TRJ COTS-Plus Series



Professional Tantalum Chip Capacitor (also available as COTS-Plus option)



The TRJ surface mount series employs the well established Tantalum technology together with the new process improvements and advanced manufacturing techniques. The robust series designs enable to extend the guaranteed 0.5% reliability level to 1000 hours at rated voltage, rated temperature and 0.1Ω/volt circuit impedance. The moisture penetration barrier, thicker external dielectric layer and modified manganising process make the capacitor more robust against higher thermo-mechanical stresses during

assembly process (“lead-free” soldering) and also more robust against more severe working conditions at Automotive, Medical, Aircraft, Military and other applications. The temperature range is -55°C to 125°C and voltage range is 6.3V to 35V.

These components do not contain any lead either in the internal structure or in the termination plating. They are compatible with all SnPb and “lead-free” solders and are qualified for higher reflow temperature necessary for new “lead-free” assembly process.

CASE DIMENSIONS: millimeters (inches)

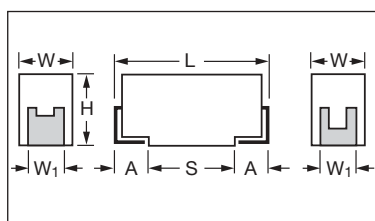

Code	EIA Code	L±0.20 (0.008)	W+0.20 (0.008) -0.10 (0.004)	H+0.20 (0.008) -0.10 (0.004)	W ₁ ±0.10 (0.004)	A+0.30 (0.012) -0.10 (0.004)	S Min.
A	3216-18	3.20 (0.126)	1.60 (0.063)	1.60 (0.063)	1.20 (0.047)	0.80 (0.031)	1.10 (0.043)
B	3528-21	3.50 (0.138)	2.80 (0.110)	1.90 (0.075)	2.20 (0.087)	0.80 (0.031)	1.40 (0.055)
C	6032-28	6.00 (0.236)	3.20 (0.126)	2.60 (0.102)	2.20 (0.087)	1.30 (0.051)	2.90 (0.114)
D	7343-31	7.30 (0.287)	4.30 (0.169)	2.90 (0.114)	2.40 (0.094)	1.30 (0.051)	4.40 (0.173)
E	7343-43	7.30 (0.287)	4.30 (0.169)	4.10 (0.162)	2.40 (0.094)	1.30 (0.051)	4.40 (0.173)

W₁ dimension applies to the termination width for A dimensional area only.

HOW TO ORDER – FOR COTS-Plus PRODUCTS

TRJ

Type

B

Case Code

105

Capacitance Code

pF code: 1st two digits represent significant figures
3rd digit represents multiplier (number of zeros to follow)

M

Tolerance

K = ±10%
M = ±20%

035

Rated DC Voltage

006 = 6.3Vdc
010 = 10Vdc
016 = 16Vdc
020 = 20Vdc
025 = 25Vdc
035 = 35Vdc

E

Packaging/
Termination Plating

E = non modular quantity tin/lead termination finish

C000

Additional characters may be added for special requirements (see below)

Suffix details

First digit

C = for COTS-Plus

Second digit

0 (zero) = for no surge requirement
S = for 10 cycles, 25°C surge
T = for 10 cycles, -55 and 85°C surge

Third digit

0 (zero) = standard ESR
L = for low ESR

Fourth digit

0 (zero) = standard M/L level reliability
B = for Weibull grade “B”
C = for Weibull grade “C”
Z = for non ER

TECHNICAL SPECIFICATIONS

Technical Data:

All technical data relate to an ambient temperature of +25°C

Capacitance Range:

0.1μF to 470μF

Capacitance Tolerance:

±10%; ±20%

Rated Voltage (V_R)

< +85°C:

6.3 10 16 20 25 35

Category Voltage (V_C)

< +125°C:

4 7 10 13 17 23

Surge Voltage (V_S)

< +85°C:

8 13 20 26 32 46

Surge Voltage (V_S)

< +125°C:

5 8 12 16 20 28

Temperature Range:

-55°C to +125°C

Reliability:

0.5% per 1000 hours at 85°C, V_R with 0.1Ω/V series impedance, 60% confidence level

Qualification:

CECC 30801 - 005 issue 2
EIA 535BAAC

Termination Plating:

Tin Plating (lead-free). Gold and SnPb Plating upon request

TRJ COTS-Plus Series



Professional Tantalum Chip Capacitor (also available as COTS-Plus option)

CAPACITANCE AND RATED VOLTAGE, V_R (VOLTAGE CODE) RANGE LETTER DENOTES CASE CODE

Capacitance μF	Code	Rated Voltage DC (V_R) to 85°C					
		6.3V	10V	16V	20V	25V	35V
0.1 0.15 0.22	104 154 224						A A A
0.33 0.47 0.68	334 474 684					A A	A A A
1 1.5 2.2	105 155 225			A	A A A	A A A/B	A/B A/B B
3.3 4.7 6.8	335 475 685		A A	A A/B A/B	A/B A/B B	B B B/C	B/C B/C C
10 15 22	106 156 226	A A/B A/B	A/B A/B B	B B C	B/C B/C C/D	C C/D C/D	C/D C/D D
33 47 68	336 476 686	B B/C C	B/C C C	C C/D D	C/D D D/E	D D/E	D/E
100 150 220	107 157 227	C C/D D	D D/E D/E	D/E E	D/E		
330 470	337 477	E E	E				

Note: Voltage ratings are minimum values. AVX reserves the right to supply higher ratings in the same reliability standards.

Developmental Ratings - subject to change

Available Ratings

TECHNICAL INFORMATION AND PROCESS IMPROVEMENTS

Anode Process:

- well established and pure Tantalum powders
- more robust dielectric layer of Ta_2O_5 , capable to withstand higher current and voltage stress
- moisture protection barrier protects the cathode layers against damage from vaporizing water during reflow
- improved manganizing process enabled to achieve very uniform and stable cathode layers

Assembly Process and Testing:

- high temperature in line reflow with the same temperature profile as needed for lead-free soldering
- additional in line stress – Temperature cycling on 100% of the production
- more severe 100% surge testing
- X-ray inspection of the internal structure and solderability test
- 100% visual inspection of advanced automatic camera system

COTS-Plus Low ESR options available for:

Case	Capacitance	Volts	ESR Max. (Ω) @ 100 kHz
B	33	6	600
C	100	6	150
D	220	6	100
E	330	6	100
E	470	6	50
B	22	10	700
D	100	10	100
D	150	10	150
B	15	16	800
C	22	16	375
C	47	16	350
D	47	16	150
D	100	16	125
D	33	20	200
E	68	20	150
C	10	25	500
D	22	25	200
C	4.7	35	600
D	10	35	300
D	22	35	400



RATINGS & PART NUMBER REFERENCE

AVX Part No.	Case Size	Capacitance μF	DCL (μA) Max.	DF % Max.	ESR Max. (Ω) @ 100 kHz
Voltage/Code 6.3 v @ 85°C (4 v @ 125°C)					
TRJA106*006#	A	10	0.45	6	2.2
TRJA156*006#	A	15	0.68	6	2.0
TRJB156*006#	B	15	0.68	6	2.0
TRJB226*006#	B	22	0.99	6	1.9
TRJB336*006#	B	33	1.5	6	1.7
TRJB476*006#	B	47	2.1	6	1.6
TRJC476*006#	C	47	2.1	6	0.5
TRJC686*006#	C	68	3.1	6	0.5
TRJC107*006#	C	100	4.5	6	0.4
TRJD157*006#	D	150	6.8	6	0.4
TRJD227*006#	D	220	9.9	8	0.4
TRJE337*006#	E	330	14	8	0.3
Voltage/Code 10 v @ 85°C (6.3 v @ 125°C)					
TRJA475*010#	A	4.7	0.35	6	3.2
TRJA685*010#	A	6.8	0.51	6	2.6
TRJA106*010#	A	10	0.75	6	2.2
TRJB106*010#	B	10	0.75	6	2.2
TRJB156*010#	B	15	1.1	6	2.0
TRJB226*010#	B	22	1.7	6	1.9
TRJC336*010#	C	33	2.5	6	0.6
TRJC476*010#	C	47	3.5	6	0.5
TRJC686*010#	C	68	5.1	6	0.5
TRJD107*010#	D	100	7.5	6	0.4
TRJD157*010#	D	150	11	8	0.4
TRJE157*010#	E	150	11	8	0.4
TRJE227*010#	E	220	17	8	0.4
Voltage/Code 16 v @ 85°C (10 v @ 125°C)					
TRJA225*016#	A	2.2	0.30	6	4.5
TRJA335*016#	A	3.3	0.40	6	3.7
TRJA475*016#	A	4.7	0.56	6	3.2
TRJB475*016#	B	4.7	0.56	6	3.2
TRJB685*016#	B	6.8	0.82	6	2.6
TRJB106*016#	B	10	1.2	6	2.2
TRJB156*016#	B	15	1.8	6	2.0
TRJC226*016#	C	22	2.6	6	0.7
TRJC336*016#	C	33	4.0	6	0.6
TRJC476*016#	C	47	5.6	6	0.5
TRJD476*016#	D	47	5.6	6	0.5
TRJD686*016#	D	68	8.2	6	0.5
TRJD107*016#	D	100	12	6	0.4
TRJE107*016#	E	100	12	6	0.4

All technical data relates to an ambient temperature of +25°C. Capacitance and DF are measured at 120Hz, 0.5V RMS with a maximum DC bias of 2.2 volts. DCL is measured at rated voltage after 5 minutes.

* Insert K for $\pm 10\%$ and M for $\pm 20\%$

Termination finished and packaging reel size

NOTE: AVX reserves the right to supply higher specification parts in the same case size, to the same reliability standards.

AVX Part No.	Case Size	Capacitance μF	DCL (μA) Max.	DF % Max.	ESR Max. (Ω) @ 100 kHz
Voltage/Code 20 v @ 85°C (13 v @ 125°C)					
TRJA105*020#	A	1	0.30	4	6.6
TRJA155*020#	A	1.5	0.30	6	5.5
TRJA225*020#	A	2.2	0.33	6	4.5
TRJA335*020#	A	3.3	0.50	6	3.7
TRJB335*020#	B	3.3	0.50	6	3.7
TRJB475*020#	B	4.7	0.71	6	3.2
TRJB685*020#	B	6.8	1.0	6	2.6
TRJB106*020#	B	10	1.5	6	2.2
TRJC106*020#	C	10	1.5	6	0.8
TRJC156*020#	C	15	2.3	6	0.7
TRJC226*020#	C	22	3.3	6	0.7
TRJD226*020#	D	22	3.3	6	0.7
TRJC336*020#	C	33	5.0	6	0.6
TRJD336*020#	D	33	5.0	6	0.6
TRJD476*020#	D	47	7.1	6	0.5
TRJD686*020#	D	68	10	6	0.5
TRJE686*020#	E	68	10	6	0.5
Voltage/Code 25 v @ 85°C (16 v @ 125°C)					
TRJA474*025#	A	0.47	0.30	4	9.5
TRJA684*025#	A	0.68	0.30	4	8.0
TRJA105*025#	A	1	0.30	4	6.6
TRJA155*025#	A	1.5	0.30	6	5.5
TRJB225*025#	B	2.2	0.41	6	4.5
TRJB335*025#	B	3.3	0.62	6	3.7
TRJB475*025#	B	4.7	0.88	6	3.2
TRJC685*025#	C	6.8	1.3	6	1.1
TRJC106*025#	C	10	1.9	6	0.8
TRJC156*025#	C	15	2.8	6	0.7
TRJD156*025#	D	15	2.8	6	0.7
TRJD226*025#	D	22	4.1	6	0.7
TRJD336*025#	D	33	6.2	6	0.6
TRJE476*025#	E	47	8.8	6	0.5
Voltage/Code 35 v @ 85°C (23 v @ 125°C)					
TRJA104*035#	A	0.1	0.30	4	20
TRJA154*035#	A	0.15	0.30	4	16
TRJA224*035#	A	0.22	0.30	4	14
TRJA334*035#	A	0.33	0.30	4	11
TRJA474*035#	A	0.47	0.30	4	9.5
TRJA684*035#	A	0.68	0.30	4	8.0
TRJA105*035#	A	1	0.30	4	6.6
TRJB105*035#	B	1	0.30	4	6.6
TRJB155*035#	B	1.5	0.39	6	5.5
TRJB225*035#	B	2.2	0.58	6	4.5
TRJB335*035#	B	3.3	0.87	6	3.7
TRJC335*035#	C	3.3	0.87	6	1.8
TRJC475*035#	C	4.7	1.2	6	1.4
TRJC685*035#	C	6.8	1.8	6	1.1
TRJC106*035#	C	10	2.6	6	0.8
TRJD106*035#	D	10	2.6	6	0.8
TRJD156*035#	D	15	3.9	6	0.7
TRJD226*035#	D	22	5.8	6	0.7
TRJE336*035#	E	33	8.7	6	0.6

KEY FEATURES

- Weibull graded
- Reliability 0.1% / K hrs
- Low leakage
- Conformance testing (Lot by Lot)
- Extended traceability
- Approved for use in life support medical devices

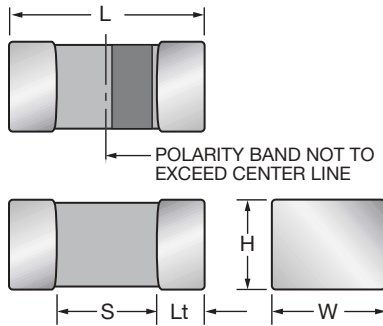

CASE DIMENSIONS: millimeters (inches)

Code	EIA Code	Length (L)	Width (W)	Height (H)	Termination Length (Lt)	Typical Mass
K	0402	1.00 ^{+0.20} _{-0.00} (0.039 ^{+0.008} _{-0.000})	0.50 ^{+0.20} _{-0.00} (0.020 ^{+0.008} _{-0.000})	0.50 ^{+0.20} _{-0.00} (0.020 ^{+0.008} _{-0.000})	0.10 (0.004)	2.0mg
L	0603	1.60 ^{+0.25} _{-0.15} (0.063 ^{+0.010} _{-0.006})	0.85 ^{+0.20} _{-0.10} (0.033 ^{+0.008} _{-0.004})	0.85 ^{+0.20} _{-0.00} (0.033 ^{+0.008} _{-0.004})	0.15 (0.006)	8.6mg
R	0805	2.00 ^{+0.25} _{-0.15} (0.079 ^{+0.010} _{-0.006})	1.35 ^{+0.20} _{-0.10} (0.053 ^{+0.008} _{-0.004})	1.35 ^{+0.20} _{-0.10} (0.053 ^{+0.008} _{-0.004})	0.15 (0.006)	29.9mg
A	1206	3.20±0.20 (0.126±0.008)	1.60 ^{+0.00} _{-0.20} (0.063 ^{+0.000} _{-0.008})	1.60 ^{+0.00} _{-0.20} (0.063 ^{+0.000} _{-0.008})	0.15 (0.006)	44.6mg

HOW TO ORDER

TMC	R	106	M	010	E	**
Type TACmicrochip™	Case Code 0402 = K 0603=L 0805=R 1206=A	Capacitance Code pF code: 1st two digits represent significant figures, 3rd digit represents multiplier (number of zeros to follow)	Tolerance K = ±10% M = ±20%	Rated DC Voltage 002 = 2Vdc 003 = 3Vdc 004 = 4Vdc 006 = 6.3Vdc 010 = 10Vdc 016 = 16Vdc	Packaging E = Non Modular Tin Termination D = Non Modular Gold Termination (see table below)	Additional characters may be add for special requirements

Packaging Suffix

RTA – Std. termination (Nickel & Tin) supplied on plastic embossed tape on a 4mm pitch in a 7" diameter reel.

XTA – Std. termination (Nickel & Tin) supplied on plastic embossed tape on a 4mm pitch in a 4.25" diameter reel.

PTA – Std. termination (Nickel & Tin) supplied on punched paper tape on a 2mm pitch in a 7" diameter reel.

QTA – Std. termination (Nickel & Tin) supplied on punched paper tape on a 2mm pitch in a 4.25" diameter reel.

ATA – Nickel & thin Gold plated termination, supplied on plastic embossed tape on a 4mm pitch in a 7" diameter reel.

FTA – Nickel & thin Gold plated termination, supplied on plastic embossed tape on a 4mm pitch in a 4.25" diameter reel.

Packaging Suffix

Reel Size	Standard Tin Termination Plastic Tape 1206/0805/0603	Standard Tin Termination Paper Tape 0402	Gold Termination Plastic Tape 1206/0805/0603
7"	Rxx	Pxx	Axx
4¼"	Xxx	Qxx	Fxx

ESTABLISHED RELIABILITY RANGE (EIA Sizes)

(LETTER DENOTES CASE SIZE)

Capacitance		Voltage Rating DC (VR) at 85°C				
Cap. (µF)	Code	3.0V	4.0V	6.3V	10V	16V
0.33	334					
0.47	474				K/L	L
0.68	684				K/L	L
1.0	105			K	L	L
1.5	155			K	L	L
2.2	225				L/R	L
3.3	335			L	R	
4.7	475			R	R	
6.8	685				R	
10	106		R	R	R	R
15	156	R	R		R	
22	226		R	R	A	
33	336	R	R	A		
47	476		A			
68	686					
100	107					
150	157			TAK		
220	227					

Case Size		Case Letter Released
1005M	0402	K
1608M	0603	L
2012M	0805	R
3216M	1206	A

Available Ratings

Developmental Ratings - subject to change

Production Processing, Test, and Inspection

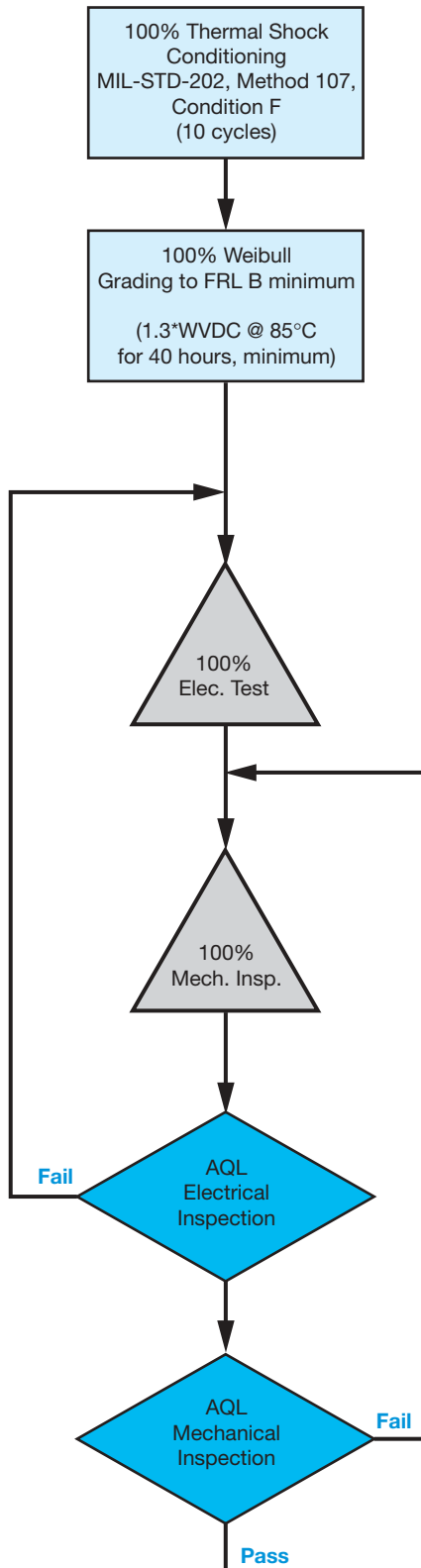

Simulated Function Test

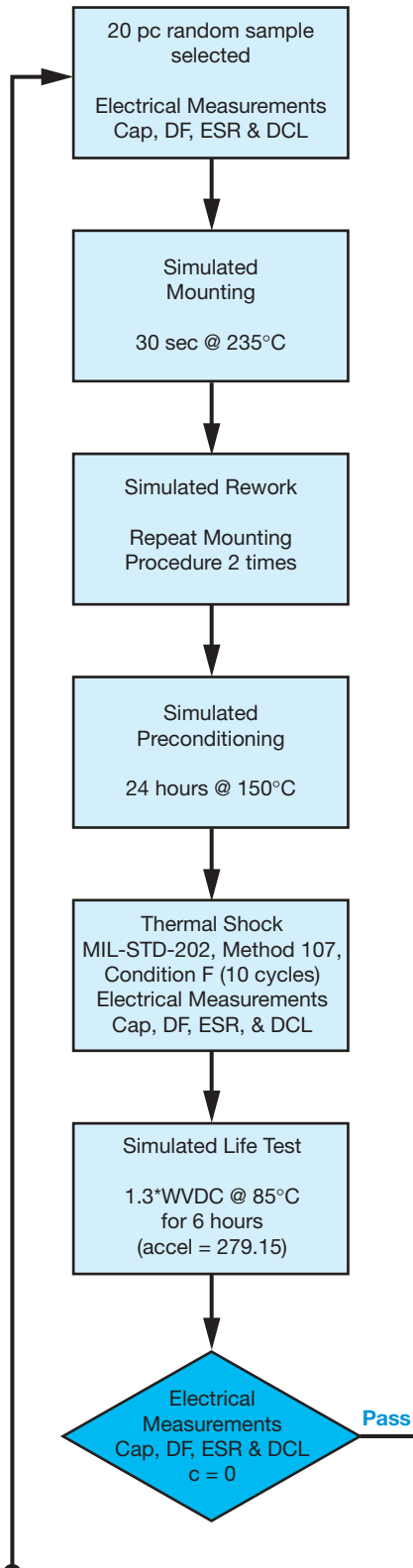

Additional Function Tests

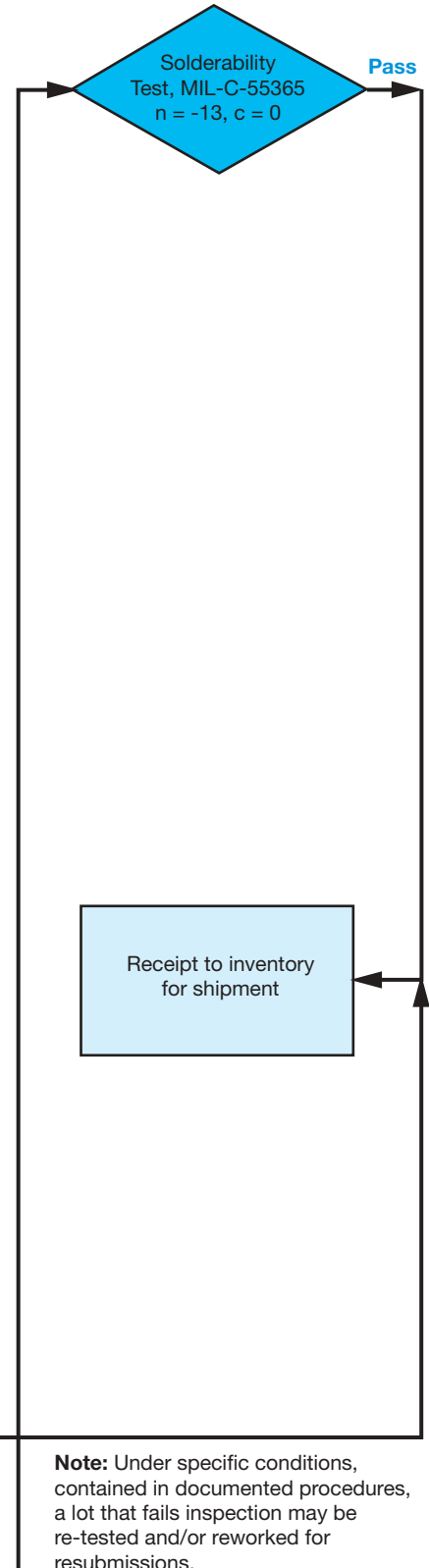

Note: Under specific conditions, contained in documented procedures, a lot that fails inspection may be re-tested and/or reworked for resubmissions.

Electrical test parameters are set in accordance with customer's specification.

SMPS Stacked MLC Capacitors

(SM Style) SM Military Styles MIL-PRF-49470



U.S. Preferred Styles

AVX IS QUALIFIED TO MIL-PRF-49470/01 AND MIL-PRF-49470/02

The SMPS capacitors are designed for high current, high-power and high-temperature applications. These capacitors have very low ESR (Equivalent Series Resistance) and ESL (Equivalent Series Inductance). SMPS Series capacitors offer design and component engineers a proven technology specifically designed for programs requiring high reliability performance in harsh environments.

MIL-PRF-49470 SMPS Series capacitors are primarily used in input/output filters of high-power and high-voltage power supplies as well as in bus filters and DC snubbers for high power inverters and other high-current applications. These capacitors are available with through-hole and surface mount leads. The operating temperature is -55°C to +125°C. The MIL-PRF-49470 capacitors are preferred over the DSCC

drawing 87106 capacitors. MIL-PRF-49470 specification was created to produce a robust replacement for DSCC 87106. MIL-PRF-49470 offers two product levels.

Level “B” is the standard reliability. Level “T” is the high reliability suitable for space application.

AVX is qualified to supply MIL-PRF-49470/01 parts. These are unencapsulated ceramic dielectric, switch mode power supply capacitors. AVX is also qualified to supply MIL-PRF-49470/02 parts. These are encapsulated ceramic dielectric, switch mode power supply capacitors.

PLEASE CONTACT THE DSCC WEBSITE

[\[http://www.dscclia.mil/Programs/MilSpec/DocSearch.asp\]](http://www.dscclia.mil/Programs/MilSpec/DocSearch.asp) for details on testing, electrical, mechanical and part number options.

PLEASE CONTACT THE DSCC WEBSITE

[\[http://www.dscclia.mil/Programs/QmlQpl/\]](http://www.dscclia.mil/Programs/QmlQpl/) for the latest QPL (Qualified Products List).

HOW TO ORDER

M49470

R

01

474

K

C

N

Performance specification indicating MIL-PRF-49470

Characteristic

Performance specification sheet number
01 – indicating MIL-PRF-49470/01
02 – indicating MIL-PRF-49470/02

Capacitance

Capacitance Tolerance

Rated Voltage

Configuration

For “T” level parts, replace the “M” in the pin with “T” (for example M49470R01474KCN becomes T49470R01474KCN) MIL-PRF-49470 contains additional capacitors that are not available in 87106, such as additional lead configurations and lower profile parts.

On the pages to follow is the general dimensional outline along with a cross reference from 87106 parts to MIL-PRF-49470 parts.



SMPS Stacked MLC Capacitors

(SM Style) SM Military Styles MIL-PRF-49470/01



U.S. Preferred Styles

MIL-PRF-49470/01

MIL-PRF-49470/01 - capacitor, fixed, ceramic dielectric, switch mode power supply (general purpose and temperature stable), standard reliability and high reliability unencapsulated, Style PS01.

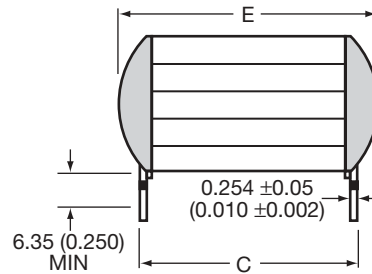
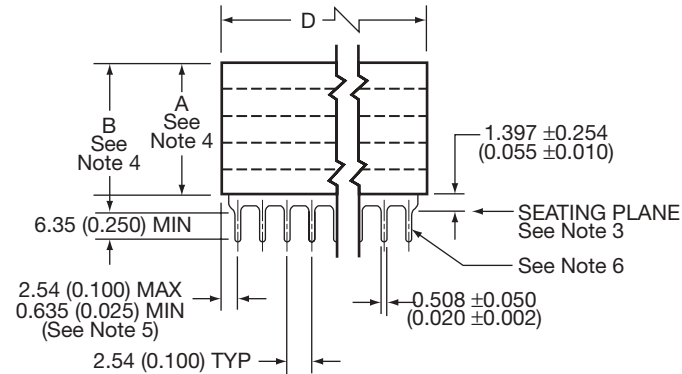

LEAD STYLE N

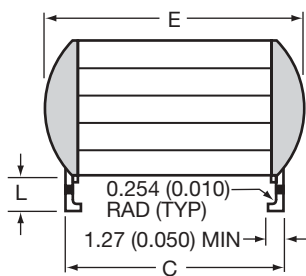

LEAD STYLE J

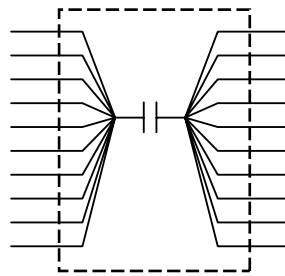

CIRCUIT DIAGRAM

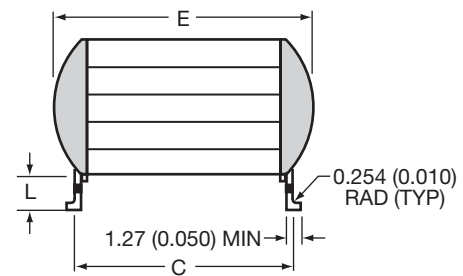

LEAD STYLE L

DIMENSIONS:

millimeters (inches)

Case Code	C ±0.635 (±0.025)	D		E (max.)	Number of Leads per side
		Min.	Max.		
1	11.4 (0.450)	49.5 (1.950)	52.7 (2.075)	12.7 (0.500)	20
2	20.3 (0.800)	36.8 (1.450)	40.0 (1.535)	22.1 (0.870)	15
3	11.4 (0.450)	24.1 (0.950)	27.3 (1.075)	12.7 (0.500)	10
4	10.2 (0.400)	8.89 (0.350)	10.8 (0.425)	11.2 (0.440)	4
5	6.35 (0.250)	6.20 (0.224)	6.97 (0.275)	7.62 (0.300)	3
6	31.8 (1.250)	49.5 (1.950)	52.7 (2.075)	34.3 (1.350)	20

NOTES:

- Dimensions are in millimeters (inches)
- Unless otherwise specified, tolerances are 0.254 (±0.010).
- Lead frame configuration is shown as typical above the seating plane.
- See table 1 for specific maximum A dimension. For maximum B dimension, add 1.65 (0.065) to the appropriate A dimension. For all lead styles, the number of chips is determined by the capacitance and voltage rating.
- For case code 5, dimensions shall be 2.54 (0.100) maximum and 0.305 (0.012) minimum.
- Lead alignment within pin rows shall be within ±0.10 (0.005).



SMPS Stacked MLC Capacitors

(SM Style) SM Military Styles MIL-PRF-49470/02



U.S. Preferred Styles

MIL-PRF-49470/02

MIL-PRF-49470/02 - capacitor, fixed, ceramic dielectric, switch mode power supply (general purpose and temperature stable), standard reliability and high reliability encapsulated, Style PS02.

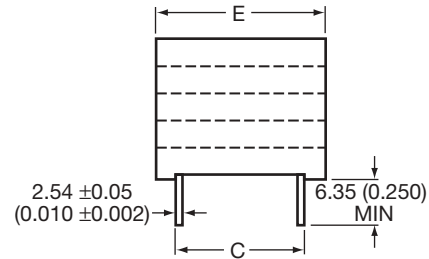
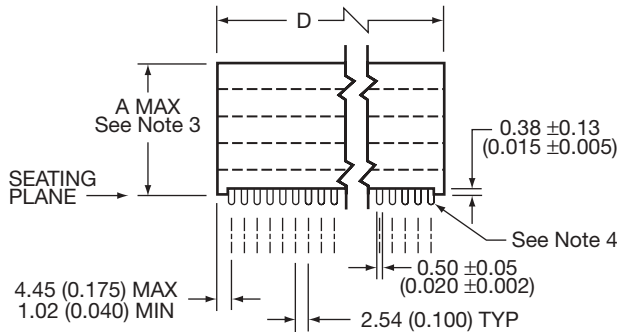

LEAD STYLE N

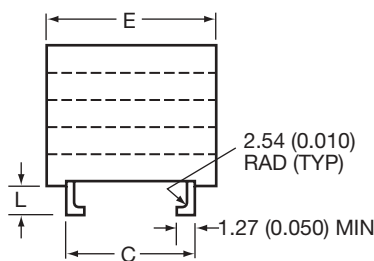

LEAD STYLE J

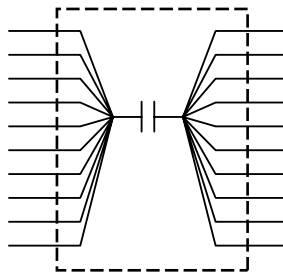

CIRCUIT DIAGRAM

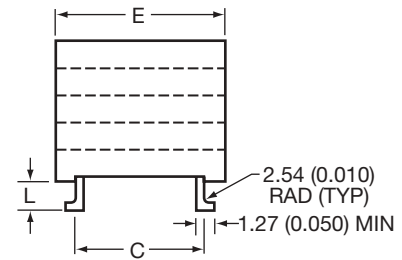

LEAD STYLE L

DIMENSIONS:

millimeters (inches)

Case Code	C ±0.635 (±0.025)	D ±0.635 (±0.025)	E (max)	Number of Leads per side
1	11.4 (0.450)	54.7 (2.155)	14.7 (0.580)	20
2	20.3 (0.800)	41.0 (1.615)	24.1 (0.950)	15
3	11.4 (0.450)	29.3 (1.155)	14.7 (0.580)	10
4	10.2 (0.400)	12.3 (0.485)	12.3 (0.485)	4
5	6.35 (0.250)	9.02 (0.355)	9.02 (0.355)	3
6	31.8 (1.250)	54.7 (2.155)	36.3 (1.430)	20

NOTES:

1. Dimensions are in millimeters (inches)
2. Unless otherwise specified, tolerances are 0.254 (±0.010).
3. See table 1 for specific maximum A dimension. For all lead styles, the number of chips is determined by the capacitance and voltage rating.
4. Lead alignment within pin rows shall be within ±0.10 (0.005).



SMPS Stacked MLC Capacitors

(SM Style) SM Military Styles MIL-PRF-49470



U.S. Preferred Styles

87106-	MIL-PRF-49470 PIN	AVX PART NUMBER	CAP (µF)	TOL	CASE CODE	VOLT (VDC)
1	M49470X01105KAN	SM055C105KHN120	1.0	±10%	5	50
2	M49470X01105MAN	SM055C105MHN120	1.0	±20%	5	50
3	M49470X01125KAN	SM055C125KHN120	1.2	±10%	5	50
4	M49470X01125MAN	SM055C125MHN120	1.2	±20%	5	50
5	M49470X01155KAN	SM055C155KHN240	1.5	±10%	5	50
6	M49470X01155MAN	SM055C155MHN240	1.5	±20%	5	50
7	M49470X01185KAN	SM055C185KHN240	1.8	±10%	5	50
8	M49470X01185MAN	SM055C185MHN240	1.8	±20%	5	50
9	M49470X01225KAN	SM055C225KHN240	2.2	±10%	5	50
10	M49470X01225MAN	SM055C225MHN240	2.2	±20%	5	50
11	M49470X01275KAN	SM055C275KHN360	2.7	±10%	5	50
12	M49470X01275MAN	SM055C275MHN360	2.7	±20%	5	50
13	M49470X01335KAN	SM055C335KHN360	3.3	±10%	5	50
14	M49470X01335MAN	SM055C335MHN360	3.3	±20%	5	50
15	M49470X01395KAN	SM055C395KHN480	3.9	±10%	5	50
16	M49470X01395MAN	SM055C395MHN480	3.9	±20%	5	50
17	M49470X01475KAN	SM055C475KHN480	4.7	±10%	5	50
18	M49470X01475MAN	SM055C475MHN480	4.7	±20%	5	50
	M49470X01475KAA	SM045C475KHN240	4.7	±10%	4	50
	M49470X01475MAA	SM045C475MHN240	4.7	±20%	4	50
19	M49470X01565KAN	SM055C565KHN650	5.6	±10%	5	50
20	M49470X01565MAN	SM055C565MHN650	5.6	±20%	5	50
	M49470X01565KAA	SM045C565KHN240	5.6	±10%	4	50
	M49470X01565MAA	SM045C565MHN240	5.6	±20%	4	50
21	M49470X01825KAN	SM045C825KHN360	8.2	±10%	4	50
22	M49470X01825MAN	SM045C825MHN360	8.2	±20%	4	50
23	M49470X01106KAN	SM045C106KHN480	10	±10%	4	50
24	M49470X01106MAN	SM045C106MHN480	10	±20%	4	50
25	M49470X01126KAN	SM045C126KHN480	12	±10%	4	50
26	M49470X01126MAN	SM045C126MHN480	12	±20%	4	50
27	M49470X01156KAN	SM045C156KHN650	15	±10%	4	50
28	M49470X01156MAN	SM045C156MHN650	15	±20%	4	50
	M49470X01156KAA	SM035C156KHN240	15	±10%	3	50
	M49470X01156MAA	SM035C156MHN240	15	±20%	3	50
29	M49470X01186KAN	SM035C186KHN240	18	±10%	3	50
30	M49470X01186MAN	SM035C186MHN240	18	±20%	3	50
31	M49470X01226KAN	SM035C226KHN360	22	±10%	3	50
32	M49470X01226MAN	SM035C226MHN360	22	±20%	3	50
33	M49470X01276KAN	SM035C276KHN360	27	±10%	3	50
34	M49470X01276MAN	SM035C276MHN360	27	±20%	3	50
35	M49470X01336KAN	SM035C336KHN360	33	±10%	3	50
36	M49470X01336MAN	SM035C336MHN360	33	±20%	3	50
37	M49470X01396KAN	SM035C396KHN480	39	±10%	3	50
38	M49470X01396MAN	SM035C396MHN480	39	±20%	3	50
39	M49470X01476KAN	SM035C476KHN650	47	±10%	3	50
40	M49470X01476MAN	SM035C476MHN650	47	±20%	3	50
	M49470X01476KAA	SM025C476KHN240	47	±10%	2	50
	M49470X01476MAA	SM025C476MHN240	47	±20%	2	50
41	M49470X01686KAN	SM015C686KHN480	68	±10%	1	50
42	M49470X01686MAN	SM015C686MHN480	68	±20%	1	50
	M49470X01686KAA	SM025C686KHN360	68	±10%	2	50
	M49470X01686MAA	SM025C686MHN360	68	±20%	2	50
43	M49470X01826KAN	SM015C826KHN480	82	±10%	1	50
44	M49470X01826MAN	SM015C826MHN480	82	±20%	1	50
	M49470X01826KAA	SM025C826KHN360	82	±10%	2	50
	M49470X01826MAA	SM025C826MHN360	82	±20%	2	50
45	M49470X01107KAN	SM015C107KHN650	100	±10%	1	50
46	M49470X01107MAN	SM015C107MHN650	100	±20%	1	50
	M49470X01107KAA	SM025C107KHN480	100	±10%	2	50
	M49470X01107MAA	SM025C107MHN480	100	±20%	2	50
47	M49470X01157KAN	SM025C157KHN650	150	±10%	2	50
48	M49470X01157MAN	SM025C157MHN650	150	±20%	2	50

87106-	MIL-PRF-49470 PIN	AVX PART NUMBER	CAP (µF)	TOL	CASE CODE	VOLT (VDC)
49	M49470X01187KAN	SM065C187KHN480	180	±10%	6	50
50	M49470X01187MAN	SM065C187MHN480	180	±20%	6	50
51	M49470X01227KAN	SM065C227KHN480	220	±10%	6	50
52	M49470X01227MAN	SM065C227MHN480	220	±20%	6	50
53	M49470X01277KAN	SM065C277KHN650	270	±10%	6	50
54	M49470X01277MAN	SM065C277MHN650	270	±20%	6	50
55	M49470X01684KBN	SM051C684KHN120	0.68	±10%	5	100
56	M49470X01684MBN	SM051C684MHN120	0.68	±20%	5	100
57	M49470X01824KBN	SM051C824KHN240	0.82	±10%	5	100
58	M49470X01824MBN	SM051C824MHN240	0.82	±20%	5	100
59	M49470X01105KBN	SM051C105KHN240	1.0	±10%	5	100
60	M49470X01105MBN	SM051C105MHN240	1.0	±20%	5	100
61	M49470X01125KBN	SM051C125KHN240	1.2	±10%	5	100
62	M49470X01125MBN	SM051C125MHN240	1.2	±20%	5	100
63	M49470X01155KBN	SM051C155KHN360	1.5	±10%	5	100
64	M49470X01155MBN	SM051C155MHN360	1.5	±20%	5	100
65	M49470X01185KBN	SM051C185KHN360	1.8	±10%	5	100
66	M49470X01185MBN	SM051C185MHN360	1.8	±20%	5	100
67	M49470X01225KBN	SM051C225KHN480	2.2	±10%	5	100
68	M49470X01225MBN	SM051C225MHN480	2.2	±20%	5	100
	M49470X01225KBA	SM041C225KHN240	2.2	±10%	4	100
	M49470X01225MBA	SM041C225MHN240	2.2	±20%	4	100
69	M49470X01275KBN	SM051C275KHN480	2.7	±10%	5	100
70	M49470X01275MBN	SM051C275MHN480	2.7	±20%	5	100
71	M49470X01335KBN	SM051C335KHN650	3.3	±10%	5	100
72	M49470X01335MBN	SM051C335MHN650	3.3	±20%	5	100
	M49470X01335KBA	SM041C335KHN240	3.3	±10%	4	100
	M49470X01335MBA	SM041C335MHN240	3.3	±20%	4	100
73	M49470X01395KBN	SM041C395KHN360	3.9	±10%	4	100
74	M49470X01395MBN	SM041C395MHN360	3.9	±20%	4	100
75	M49470X01475KBN	SM041C475KHN360	4.7	±10%	4	100
76	M49470X01475MBN	SM041C475MHN360	4.7	±20%	4	100
77	M49470X01565KBN	SM041C565KHN480	5.6	±10%	4	100
78	M49470X01565MBN	SM041C565MHN480	5.6	±20%	4	100
79	M49470X01685KBN	SM041C685KHN480	6.8	±10%	4	100
80	M49470X01685MBN	SM041C685MHN480	6.8	±20%	4	100
81	M49470X01825KBN	SM041C825KHN650	8.2	±10%	4	100
82	M49470X01825MBN	SM041C825MHN650	8.2	±20%	4	100
	M49470X01825KBA	SM031C825KHN240	8.2	±10%	3	100
	M49470X01825MBA	SM031C825MHN240	8.2	±20%	3	100
83	M49470X01126KBN	SM031C126KHN240	12	±10%	3	100
84	M49470X01126MBN	SM031C126MHN240	12	±20%	3	100
85	M49470X01156KBN	SM031C156KHN360	15	±10%	3	100
86	M49470X01156MBN	SM031C156MHN360	15	±20%	3	100
87	M49470X01186KBN	SM031C186KHN360	18	±10%	3	100
88	M49470X01186MBN	SM031C186MHN360	18	±20%	3	100
89	M49470X01226KBN	SM031C226KHN480	22	±10%	3	100
90	M49470X01226MBN	SM031C226MHN480	22	±20%	3	100
91	M49470X01276KBN	SM031C276KHN650	27	±10%	3	100
92	M49470X01276MBN	SM031C276MHN650	27	±20%	3	100
	M49470X01276KBA	SM021C276KHN240	27	±10%	2	100
	M49470X01276MBA	SM021C276MHN240	27	±20%	2	100
93	M49470X01336KBN	SM011C336KHN360	33	±10%	1	100
94	M49470X01336MBN	SM011C336MHN360	33	±20%	1	100
	M49470X01336KBA	SM021C336KHN240	33	±10%	2	100
	M49470X01336MBA	SM021C336MHN240	33	±20%	2	100
95	M49470X01396KBN	SM011C396KHN480	39	±10%	1	100
96	M49470X01396MBN	SM011C396MHN480	39	±20%	1	100
	M49470X01396KBA	SM021C396KHN360	39	±10%	2	100
	M49470X01396MBA	SM021C396MHN360	39	±20%	2	100
97	M49470X01476KBN	SM011C476KHN480	47	±10%	1	100
98	M49470X01476MBN	SM011C476MHN480	47	±20%	1	100



SMPS Stacked MLC Capacitors

(SM Style) SM Military Styles MIL-PRF-49470



U.S. Preferred Styles

87106-	MIL-PRF-49470 PIN	AVX PART NUMBER	CAP (µF)	TOL	CASE CODE	VOLT (VDC)
	M49470X01476KBA	SM021C476KHN360	47	±10%	2	100
	M49470X01476MBA	SM021C476MHN360	47	±20%	2	100
99	M49470X01566KBN	SM011C566KHN650	56	±10%	1	100
100	M49470X01566MBN	SM011C566MHN650	56	±20%	1	100
101	M49470X01686KBN	SM021C686KHN480	68	±10%	2	100
102	M49470X01686MBN	SM021C686MHN480	68	±20%	2	100
103	M49470X01826KBN	SM021C826KHN650	82	±10%	2	100
104	M49470X01826MBN	SM021C826MHN650	82	±20%	2	100
105	M49470X01107KBN	SM061C107KHN360	100	±10%	6	100
106	M49470X01107MBN	SM061C107MHN360	100	±20%	6	100
107	M49470X01127KBN	SM061C127KHN360	120	±10%	6	100
108	M49470X01127MBN	SM061C127MHN360	120	±20%	6	100
109	M49470X01157KBN	SM061C157KHN480	150	±10%	6	100
110	M49470X01157MBN	SM061C157MHN480	150	±20%	6	100
111	M49470X01187KBN	SM061C187KHN650	180	±10%	6	100
112	M49470X01187MBN	SM061C187MHN650	180	±20%	6	100
113	M49470R01474KCN	SM052C474KHN240	0.47	±10%	5	200
114	M49470R01474MCN	SM052C474MHN240	0.47	±20%	5	200
115	M49470R01564KCN	SM052C564KHN240	0.56	±10%	5	200
116	M49470R01564MCN	SM052C564MHN240	0.56	±20%	5	200
117	M49470R01684KCN	SM052C684KHN360	0.68	±10%	5	200
118	M49470R01684MCN	SM052C684MHN360	0.68	±20%	5	200
119	M49470R01824KCN	SM052C824KHN360	0.82	±10%	5	200
120	M49470R01824MCN	SM052C824MHN360	0.82	±20%	5	200
121	M49470R01105KCN	SM052C105KHN480	1.0	±10%	5	200
122	M49470R01105MCN	SM052C105MHN480	1.0	±20%	5	200
	M49470R01105KCA	SM042C105KHN120	1.0	±10%	4	200
	M49470R01105MCA	SM042C105MHN120	1.0	±20%	4	200
123	M49470R01125KCN	SM052C125KHN480	1.2	±10%	5	200
124	M49470R01125MCN	SM052C125MHN480	1.2	±20%	5	200
	M49470R01125KCA	SM042C125KHN240	1.2	±10%	4	200
	M49470R01125MCA	SM042C125MHN240	1.2	±20%	4	200
125	M49470R01155KCN	SM052C155KHN650	1.5	±10%	5	200
126	M49470R01155MCN	SM052C155MHN650	1.5	±20%	5	200
	M49470R01155KCA	SM042C155KHN240	1.5	±10%	4	200
	M49470R01155MCA	SM042C155MHN240	1.5	±20%	4	200
127	M49470R01185KCN	SM042C185KHN360	1.8	±10%	4	200
128	M49470R01185MCN	SM042C185MHN360	1.8	±20%	4	200
129	M49470R01225KCN	SM042C225KHN360	2.2	±10%	4	200
130	M49470R01225MCN	SM042C225MHN360	2.2	±20%	4	200
131	M49470R01275KCN	SM042C275KHN480	2.7	±10%	4	200
132	M49470R01275MCN	SM042C275MHN480	2.7	±20%	4	200
133	M49470R01335KCN	SM042C335KHN480	3.3	±10%	4	200
134	M49470R01335MCN	SM042C335MHN480	3.3	±20%	4	200
135	M49470R01395KCN	SM042C395KHN650	3.9	±10%	4	200
136	M49470R01395MCN	SM042C395MHN650	3.9	±20%	4	200
	M49470R01395KCA	SM032C395KHN240	3.9	±10%	3	200
	M49470R01395MCA	SM032C395MHN240	3.9	±20%	3	200
137	M49470R01475KCN	SM032C475KHN240	4.7	±10%	3	200
138	M49470R01475MCN	SM032C475MHN240	4.7	±20%	3	200
139	M49470R01565KCN	SM032C565KHN240	5.6	±10%	3	200
140	M49470R01565MCN	SM032C565MHN240	5.6	±20%	3	200
141	M49470R01685KCN	SM032C685KHN360	6.8	±10%	3	200
142	M49470R01685MCN	SM032C685MHN360	6.8	±20%	3	200
143	M49470R01825KCN	SM032C825KHN360	8.2	±10%	3	200
144	M49470R01825MCN	SM032C825MHN360	8.2	±20%	3	200
145	M49470R01106KCN	SM032C106KHN480	10	±10%	3	200
146	M49470R01106MCN	SM032C106MHN480	10	±20%	3	200
147	M49470R01126KCN	SM032C126KHN650	12	±10%	3	200
148	M49470R01126MCN	SM032C126MHN650	12	±20%	3	200
	M49470R01126KCA	SM022C126KHN240	12	±10%	2	200
	M49470R01126MCA	SM022C126MHN240	12	±20%	2	200

87106-	MIL-PRF-49470 PIN	AVX PART NUMBER	CAP (µF)	TOL	CASE CODE	VOLT (VDC)
149	M49470R01156KCN	SM012C156KHN360	15	±10%	1	200
150	M49470R01156MCN	SM012C156MHN360	15	±20%	1	200
	M49470R01156KCA	SM022C156KHN240	15	±10%	2	200
	M49470R01156MCA	SM022C156MHN240	15	±20%	2	200
151	M49470R01186KCN	SM012C186KHN480	18	±10%	1	200
152	M49470R01186MCN	SM012C186MHN480	18	±20%	1	200
	M49470R01186KCA	SM022C186KHN360	18	±10%	2	200
	M49470R01186MCA	SM022C186MHN360	18	±20%	2	200
153	M49470R01226KCN	SM012C226KHN650	22	±10%	1	200
154	M49470R01226MCN	SM012C226MHN650	22	±20%	1	200
	M49470R01226KCA	SM022C226KHN360	22	±10%	2	200
	M49470R01226MCA	SM022C226MHN360	22	±20%	2	200
155	M49470R01276KCN	SM012C276KHN650	27	±10%	1	200
156	M49470R01276MCN	SM012C276MHN650	27	±20%	1	200
	M49470R01276KCA	SM022C276KHN480	27	±10%	2	200
	M49470R01276MCA	SM022C276MHN480	27	±20%	2	200
157	M49470R01336KCN	SM022C336KHN480	33	±10%	2	200
158	M49470R01336MCN	SM022C336MHN480	33	±20%	2	200
159	M49470R01396KCN	SM022C396KHN650	39	±10%	2	200
160	M49470R01396MCN	SM022C396MHN650	39	±20%	2	200
161	M49470R01476KCN	SM062C476KHN240	47	±10%	6	200
162	M49470R01476MCN	SM062C476MHN240	47	±20%	6	200
163	M49470R01566KCN	SM062C566KHN360	56	±10%	6	200
164	M49470R01566MCN	SM062C566MHN360	56	±20%	6	200
165	M49470R01686KCN	SM062C686KHN360	68	±10%	6	200
166	M49470R01686MCN	SM062C686MHN360	68	±20%	6	200
167	M49470R01826KCN	SM062C826KHN480	82	±10%	6	200
168	M49470R01826MCN	SM062C826MHN480	82	±20%	6	200
169	M49470R01107KCN	SM062C107KHN650	100	±10%	6	200
170	M49470R01107MCN	SM062C107MHN650	100	±20%	6	200
171	M49470R01127KCN	SM062C127KHN650	120	±10%	6	200
172	M49470R01127MCN	SM062C127MHN650	120	±20%	6	200
173	M49470Q01154KEN	SM057C154KHN120	0.15	±10%	5	500
174	M49470Q01154MEN	SM057C154MHN120	0.15	±20%	5	500
175	M49470Q01184KEN	SM057C184KHN240	0.18	±10%	5	500
176	M49470Q01184MEN	SM057C184MHN240	0.18	±20%	5	500
177	M49470Q01224KEN	SM057C224KHN240	0.22	±10%	5	500
178	M49470Q01224MEN	SM057C224MHN240	0.22	±20%	5	500
179	M49470Q01274KEN	SM057C274KHN240	0.27	±10%	5	500
180	M49470Q01274MEN	SM057C274MHN240	0.27	±20%	5	500
181	M49470Q01334KEN	SM057C334KHN360	0.33	±10%	5	500
182	M49470Q01334MEN	SM057C334MHN360	0.33	±20%	5	500
183	M49470Q01394KEN	SM057C394KHN360	0.39	±10%	5	500
184	M49470Q01394MEN	SM057C394MHN360	0.39	±20%	5	500
185	M49470Q01474KEN	SM057C474KHN360	0.47	±10%	5	500
186	M49470Q01474MEN	SM057C474MHN360	0.47	±20%	5	500
187	M49470Q01564KEN	SM057C564KHN480	0.56	±10%	5	500
188	M49470Q01564MEN	SM057C564MHN480	0.56	±20%	5	500
	M49470Q01564KEA	SM047C564KHN240	0.56	±10%	4	500
	M49470Q01564MEA	SM047C564MHN240	0.56	±20%	4	500
189	M49470Q01684KEN	SM057C684KHN650	0.68	±10%	5	500
190	M49470Q01684MEN	SM057C684MHN650	0.68	±20%	5	500
	M49470Q01684KEA	SM047C684KHN360	0.68	±10%	4	500
	M49470Q01684MEA	SM047C684MHN360	0.68	±20%	4	500
191	M49470Q01105KEN	SM047C105KHN360	1.0	±10%	4	500
192	M49470Q01105MEN	SM047C105MHN360	1.0	±20%	4	500
193	M49470Q01125KEN	SM047C125KHN360	1.2	±10%	4	500
194	M49470Q01125MEN	SM047C125MHN360	1.2	±20%	4	500
195	M49470Q01155KEN	SM047C155KHN480	1.5	±10%	4	500
196	M49470Q01155MEN	SM047C155MHN480	1.5	±20%	4	500
197	M49470Q01185KEN	SM047C185KHN650	1.8	±10%	4	500
198	M49470Q01185MEN	SM047C185MHN650	1.8	±20%	4	500



SMPS Stacked MLC Capacitors

(SM Style) SM Military Styles MIL-PRF-49470



U.S. Preferred Styles

87106-	MIL-PRF-49470 PIN	AVX PART NUMBER	CAP (µF)	TOL	CASE CODE	VOLT (VDC)
	M49470Q01185KEA	SM037C185KHN240	1.8	±10%	3	500
	M49470Q01185MEA	SM037C185MHN240	1.8	±20%	3	500
199	M49470Q01275KEN	SM037C275KHN360	2.7	±10%	3	500
200	M49470Q01275MEN	SM037C275MHN360	2.7	±20%	3	500
201	M49470Q01335KEN	SM037C335KHN360	3.3	±10%	3	500
202	M49470Q01335MEN	SM037C335MHN360	3.3	±20%	3	500
203	M49470Q01395KEN	SM037C395KHN360	3.9	±10%	3	500
204	M49470Q01395MEN	SM037C395MHN360	3.9	±20%	3	500
205	M49470Q01475KEN	SM037C475KHN480	4.7	±10%	3	500
206	M49470Q01475MEN	SM037C475MHN480	4.7	±20%	3	500
207	M49470Q01565KEN	SM037C565KHN650	5.6	±10%	3	500
208	M49470Q01565MEN	SM037C565MHN650	5.6	±20%	3	500
	M49470Q01565KEA	SM027C565KHN240	5.6	±10%	2	500
	M49470Q01565MEA	SM027C565MHN240	5.6	±20%	2	500
209	M49470Q01825KEN	SM017C825KHN480	8.2	±10%	1	500
210	M49470Q01825MEN	SM017C825MHN480	8.2	±20%	1	500
	M49470Q01825KEA	SM027C825KHN360	8.2	±10%	2	500
	M49470Q01825MEA	SM027C825MHN360	8.2	±20%	2	500
211	M49470Q01106KEN	SM017C106KHN480	10	±10%	1	500
212	M49470Q01106MEN	SM017C106MHN480	10	±20%	1	500
	M49470Q01106KEA	SM027C106KHN360	10	±10%	2	500
	M49470Q01106MEA	SM027C106MHN360	10	±20%	2	500
213	M49470Q01126KEN	SM017C126KHN650	12	±10%	1	500
214	M49470Q01126MEN	SM017C126MHN650	12	±20%	1	500
	M49470Q01126KEA	SM027C126KHN480	12	±10%	2	500
	M49470Q01126MEA	SM027C126MHN480	12	±20%	2	500
215	M49470Q01186KEN	SM027C186KHN650	18	±10%	2	500
216	M49470Q01186MEN	SM027C186MHN650	18	±20%	2	500
217	M49470Q01276KEN	SM067C276KHN360	27	±10%	6	500
218	M49470Q01276MEN	SM067C276MHN360	27	±20%	6	500
219	M49470Q01336KEN	SM067C336KHN480	33	±10%	6	500
220	M49470Q01336MEN	SM067C336MHN480	33	±20%	6	500
221	M49470Q01396KEN	SM067C396KHN650	39	±10%	6	500
222	M49470Q01396MEN	SM067C396MHN650	39	±20%	6	500
223	M49470X01685KAN	SM045C685KHN360	6.8	±10%	4	50
224	M49470X01685MAN	SM045C685MHN360	6.8	±20%	4	50
225	M49470X01566KAN	SM015C566KHN360	5.6	±10%	1	50
226	M49470X01566MAN	SM015C566MHN360	5.6	±20%	1	50
	M49470X01566KAA	SM025C566KHN240	5.6	±10%	2	50
	M49470X01566MAA	SM025C566MHN240	5.6	±20%	2	50
227	M49470X01127KAN	SM025C127KHN480	120	±10%	2	50
228	M49470X01127MAN	SM025C127MHN480	120	±20%	2	50
229	M49470X01106KBN	SM031C106KHN240	10	±10%	3	100
230	M49470X01106MBN	SM031C106MHN240	10	±20%	3	100
231	M49470Q01824KEN	SM047C824KHN360	0.82	±10%	4	500
232	M49470Q01824MEN	SM047C824MHN360	0.82	±20%	4	500
233	M49470Q01225KEN	SM037C225KHN240	2.2	±10%	3	500
234	M49470Q01225MEN	SM037C225MHN240	2.2	±20%	3	500
235	M49470Q01685KEN	SM017C685KHN480	6.8	±10%	1	500
236	M49470Q01685MEN	SM017C685MHN480	6.8	±20%	1	500
	M49470Q01685KEA	SM027C685KHN240	6.8	±10%	2	500
	M49470Q01685MEA	SM027C685MHN240	6.8	±20%	2	500
237	M49470Q01156KEN	SM027C156KHN650	15	±10%	2	500
238	M49470Q01156MEN	SM027C156MHN650	15	±20%	2	500
239	M49470Q01226KEN	SM067C226KHN360	22	±10%	6	500
240	M49470Q01226MEN	SM067C226MHN360	22	±20%	6	500
241	M49470X01105KAJ	SM055C105KHJ120	1.0	±10%	5	50
242	M49470X01105MAJ	SM055C105MHJ120	1.0	±20%	5	50
243	M49470X01125KAJ	SM055C125KHJ120	1.2	±10%	5	50
244	M49470X01125MAJ	SM055C125MHJ120	1.2	±20%	5	50
245	M49470X01155KAJ	SM055C155KHJ240	1.5	±10%	5	50
246	M49470X01155MAJ	SM055C155MHJ240	1.5	±20%	5	50

87106-	MIL-PRF-49470 PIN	AVX PART NUMBER	CAP (µF)	TOL	CASE CODE	VOLT (VDC)
247	M49470X01185KAJ	SM055C185KHJ240	1.8	±10%	5	50
248	M49470X01185MAJ	SM055C185MHJ240	1.8	±20%	5	50
249	M49470X01225KAJ	SM055C225KHJ240	2.2	±10%	5	50
250	M49470X01225MAJ	SM055C225MHJ240	2.2	±20%	5	50
251	M49470X01275KAJ	SM055C275KHJ360	2.7	±10%	5	50
252	M49470X01275MAJ	SM055C275MHJ360	2.7	±20%	5	50
253	M49470X01335KAJ	SM055C335KHJ360	3.3	±10%	5	50
254	M49470X01335MAJ	SM055C335MHJ360	3.3	±20%	5	50
255	M49470X01395KAJ	SM055C395KHJ480	3.9	±10%	5	50
256	M49470X01395MAJ	SM055C395MHJ480	3.9	±20%	5	50
257	M49470X01475KAJ	SM055C475KHJ480	4.7	±10%	5	50
258	M49470X01475MAJ	SM055C475MHJ480	4.7	±20%	5	50
	M49470X01475KAC	SM045C475KHJ240	4.7	±10%	4	50
	M49470X01475MAC	SM045C475MHJ240	4.7	±20%	4	50
259	M49470X01565KAJ	SM055C565KHJ650	5.6	±10%	5	50
260	M49470X01565MAJ	SM055C565MHJ650	5.6	±20%	5	50
	M49470X01565KAC	SM045C565KHJ240	5.6	±10%	4	50
	M49470X01565MAC	SM045C565MHJ240	5.6	±10%	4	50
261	M49470X01685KAJ	SM045C685KHJ360	6.8	±10%	4	50
262	M49470X01685MAJ	SM045C685MHJ360	6.8	±20%	4	50
263	M49470X01825KAJ	SM045C825KHJ360	8.2	±10%	4	50
264	M49470X01825MAJ	SM045C825MHJ360	8.2	±20%	4	50
265	M49470X01106KAJ	SM045C106KHJ480	10	±10%	4	50
266	M49470X01106MAJ	SM045C106MHJ480	10	±20%	4	50
267	M49470X01126KAJ	SM045C126KHJ480	12	±10%	4	50
268	M49470X01126MAJ	SM045C126MHJ480	12	±20%	4	50
269	M49470X01156KAJ	SM045C156KHJ650	15	±10%	4	50
270	M49470X01156MAJ	SM045C156MHJ650	15	±20%	4	50
	M49470X01156KAC	SM035C156KHJ240	15	±10%	3	50
	M49470X01156MAC	SM035C156MHJ240	15	±20%	3	50
271	M49470X01186KAJ	SM035C186KHJ240	18	±10%	3	50
272	M49470X01186MAJ	SM035C186MHJ240	18	±20%	3	50
273	M49470X01226KAJ	SM035C226KHJ360	22	±10%	3	50
274	M49470X01226MAJ	SM035C226MHJ360	22	±20%	3	50
275	M49470X01276KAJ	SM035C276KHJ360	27	±10%	3	50
276	M49470X01276MAJ	SM035C276MHJ360	27	±20%	3	50
277	M49470X01336KAJ	SM035C336KHJ360	33	±10%	3	50
278	M49470X01336MAJ	SM035C336MHJ360	33	±20%	3	50
279	M49470X01396KAJ	SM035C396KHJ480	39	±10%	3	50
280	M49470X01396MAJ	SM035C396MHJ480	39	±20%	3	50
281	M49470X01476KAJ	SM035C476KHJ650	47	±10%	3	50
282	M49470X01476MAJ	SM035C476MHJ650	47	±20%	3	50
	M49470X01476KAC	SM025C476KHJ240	47	±10%	2	50
	M49470X01476MAC	SM025C476MHJ240	47	±20%	2	50
283	M49470X01566KAJ	SM015C566KHJ360	56	±10%	1	50
284	M49470X01566MAJ	SM015C566MHJ360	56	±20%	1	50
	M49470X01566KAC	SM025C566KHJ240	56	±10%	2	50
	M49470X01566MAC	SM025C566MHJ240	56	±20%	2	50
285	M49470X01686KAJ	SM015C686KHJ480	68	±10%	1	50
286	M49470X01686MAJ	SM015C686MHJ480	68	±20%	1	50
	M49470X01686KAC	SM025C686KHJ360	68	±10%	2	50
	M49470X01686MAC	SM025C686MHJ360	68	±20%	2	50
287	M49470X01826KAJ	SM015C826KHJ480	82	±10%	1	50
288	M49470X01826MAJ	SM015C826MHJ480	82	±20%	1	50
	M49470X01826KAC	SM025C826KHJ360	82	±10%	2	50
	M49470X01826MAC	SM025C826MHJ360	82	±20%	2	50
289	M49470X01107KAJ	SM015C107KHJ650	100	±10%	1	50
290	M49470X01107MAJ	SM015C107MHJ650	100	±20%	1	50
	M49470X01107KAC	SM025C107KHJ480	100	±10%	2	50
	M49470X01107MAC	SM025C107MHJ480	100	±20%	2	50
291	M49470X01127KAJ	SM025C127KHJ480	120	±10%	2	50
292	M49470X01127MAJ	SM025C127MHJ480	120	±20%	2	50



SMPS Stacked MLC Capacitors

(SM Style) SM Military Styles MIL-PRF-49470



U.S. Preferred Styles

87106-	MIL-PRF-49470 PIN	AVX PART NUMBER	CAP (μF)	TOL	CASE CODE	VOLT (VDC)
	293	M49470X01157KAJ	SM025C157KHJ650	150 ±10%	2	50
	294	M49470X01157MAJ	SM025C157MHJ650	150 ±20%	2	50
	295	M49470X01187KAJ	SM065C187KHJ480	180 ±10%	6	50
	296	M49470X01187MAJ	SM065C187MHJ480	180 ±20%	6	50
	297	M49470X01227KAJ	SM065C227KHJ480	220 ±10%	6	50
	298	M49470X01227MAJ	SM065C227MHJ480	220 ±20%	6	50
	299	M49470X01277KAJ	SM065C277KHJ650	270 ±10%	6	50
	300	M49470X01277MAJ	SM065C277MHJ650	270 ±20%	6	50
	301	M49470X01684KBJ	SM051C684KHJ120	0.68 ±10%	5	100
	302	M49470X01684MBJ	SM051C684MHJ120	0.68 ±20%	5	100
	303	M49470X01824KBJ	SM051C824KHJ240	0.82 ±10%	5	100
	304	M49470X01824MBJ	SM051C824MHJ240	0.82 ±20%	5	100
	305	M49470X01105KBJ	SM051C105KHJ240	1.0 ±10%	5	100
	306	M49470X01105MBJ	SM051C105MHJ240	1.0 ±20%	5	100
	307	M49470X01125KBJ	SM051C125KHJ240	1.2 ±10%	5	100
	308	M49470X01125MBJ	SM051C125MHJ240	1.2 ±20%	5	100
	309	M49470X01155KBJ	SM051C155KHJ360	1.5 ±10%	5	100
	310	M49470X01155MBJ	SM051C155MHJ360	1.5 ±20%	5	100
	311	M49470X01185KBJ	SM051C185KHJ360	1.8 ±10%	5	100
	312	M49470X01185MBJ	SM051C185MHJ360	1.8 ±20%	5	100
	313	M49470X01225KBJ	SM051C225KHJ480	2.2 ±10%	5	100
	314	M49470X01225MBJ	SM051C225MHJ480	2.2 ±20%	5	100
		M49470X01225KBC	SM041C225KHJ240	2.2 ±10%	4	100
		M49470X01225MBC	SM041C225MHJ240	2.2 ±20%	4	100
	315	M49470X01275KBJ	SM051C275KHJ480	2.7 ±10%	5	100
	316	M49470X01275MBJ	SM051C275MHJ480	2.7 ±20%	5	100
	317	M49470X01335KBJ	SM051C335KHJ650	3.3 ±10%	5	100
	318	M49470X01335MBJ	SM051C335MHJ650	3.3 ±20%	5	100
		M49470X01335KBC	SM041C335KHJ240	3.3 ±10%	4	100
		M49470X01335MBC	SM041C335MHJ240	3.3 ±20%	4	100
	319	M49470X01395KBJ	SM041C395KHJ360	3.9 ±10%	4	100
	320	M49470X01395MBJ	SM041C395MHJ360	3.9 ±20%	4	100
	321	M49470X01475KBJ	SM041C475KHJ360	4.7 ±10%	4	100
	322	M49470X01475MBJ	SM041C475MHJ360	4.7 ±20%	4	100
	323	M49470X01565KBJ	SM041C565KHJ480	5.6 ±10%	4	100
	324	M49470X01565MBJ	SM041C565MHJ480	5.6 ±20%	4	100
	325	M49470X01685KBJ	SM041C685KHJ480	6.8 ±10%	4	100
	326	M49470X01685MBJ	SM041C685MHJ480	6.8 ±20%	4	100
	327	M49470X01825KBJ	SM041C825KHJ650	8.2 ±10%	4	100
	328	M49470X01825MBJ	SM041C825MHJ650	8.2 ±20%	4	100
		M49470X01825KBC	SM031C825KHJ240	8.2 ±10%	3	100
		M49470X01825MBC	SM031C825MHJ240	8.2 ±20%	3	100
	329	M49470X01106KBJ	SM031C106KHJ240	10 ±10%	3	100
	330	M49470X01106MBJ	SM031C106MHJ240	10 ±20%	3	100
	331	M49470X01126KBJ	SM031C126KHJ240	12 ±10%	3	100
	332	M49470X01126MBJ	SM031C126MHJ240	12 ±20%	3	100
	333	M49470X01156KBJ	SM031C156KHJ360	15 ±10%	3	100
	334	M49470X01156MBJ	SM031C156MHJ360	15 ±20%	3	100
	335	M49470X01186KBJ	SM031C186KHJ360	18 ±10%	3	100
	336	M49470X01186MBJ	SM031C186MHJ360	18 ±20%	3	100
	337	M49470X01226KBJ	SM031C226KHJ480	22 ±10%	3	100
	338	M49470X01226MBJ	SM031C226MHJ480	22 ±20%	3	100
	339	M49470X01276KBJ	SM031C276KHJ650	27 ±10%	3	100
	340	M49470X01276MBJ	SM031C276MHJ650	27 ±20%	3	100
		M49470X01276KBC	SM021C276KHJ240	27 ±10%	2	100
		M49470X01276MBC	SM021C276MHJ240	27 ±20%	2	100
	341	M49470X01336KBJ	SM011C336KHJ360	33 ±10%	1	100
	342	M49470X01336MBJ	SM011C336MHJ360	33 ±20%	1	100
		M49470X01336KBC	SM021C336KHJ240	33 ±10%	2	100
		M49470X01336MBC	SM021C336MHJ240	33 ±20%	2	100
	343	M49470X01396KBJ	SM011C396KHJ480	39 ±10%	1	100
	344	M49470X01396MBJ	SM011C396MHJ480	39 ±20%	1	100

87106-	MIL-PRF-49470 PIN	AVX PART NUMBER	CAP (μF)	TOL	CASE CODE	VOLT (VDC)
		M49470X01396KBC	SM021C396KHJ360	39 ±10%	2	100
		M49470X01396MBC	SM021C396MHJ360	39 ±20%	2	100
	345	M49470X01476KBJ	SM011C476KHJ480	47 ±10%	1	100
	346	M49470X01476MBJ	SM011C476MHJ480	47 ±20%	1	100
		M49470X01476KBC	SM021C476KHJ360	47 ±10%	2	100
		M49470X01476MBC	SM021C476MHJ360	47 ±20%	2	100
	347	M49470X01566KBJ	SM011C566KHJ650	56 ±10%	1	100
	348	M49470X01566MBJ	SM011C566MHJ650	56 ±20%	1	100
	349	M49470X01686KBJ	SM021C686KHJ480	68 ±10%	2	100
	350	M49470X01686MBJ	SM021C686MHJ480	68 ±20%	2	100
	351	M49470X01826KBJ	SM021C826KHJ650	82 ±10%	2	100
	352	M49470X01826MBJ	SM021C826MHJ650	82 ±20%	2	100
	353	M49470X01107KBJ	SM061C107KHJ360	100 ±10%	6	100
	354	M49470X01107MBJ	SM061C107MHJ360	100 ±20%	6	100
	355	M49470X01127KBJ	SM061C127KHJ360	120 ±10%	6	100
	356	M49470X01127MBJ	SM061C127MHJ360	120 ±20%	6	100
	357	M49470X01157KBJ	SM061C157KHJ480	150 ±10%	6	100
	358	M49470X01157MBJ	SM061C157MHJ480	150 ±20%	6	100
	359	M49470X01187KBJ	SM061C187KHJ650	180 ±10%	6	100
	360	M49470X01187MBJ	SM061C187MHJ650	180 ±20%	6	100
	361	M49470R01474KCJ	SM052C474KHJ240	0.47 ±10%	5	200
	362	M49470R01474MCJ	SM052C474MHJ240	0.47 ±20%	5	200
	363	M49470R01564KCJ	SM052C564KHJ240	0.56 ±10%	5	200
	364	M49470R01564MCJ	SM052C564MHJ240	0.56 ±20%	5	200
	365	M49470R01684KCJ	SM052C684KHJ360	0.68 ±10%	5	200
	366	M49470R01684MCJ	SM052C684MHJ360	0.68 ±20%	5	200
	367	M49470R01824KCJ	SM052C824KHJ360	0.82 ±10%	5	200
	368	M49470R01824MCJ	SM052C824MHJ360	0.82 ±20%	5	200
	369	M49470R01105KCJ	SM052C105KHJ480	1.0 ±10%	5	200
	370	M49470R01105MCJ	SM052C105MHJ480	1.0 ±20%	5	200
		M49470R01105KCC	SM042C105KHJ120	1.0 ±10%	4	200
		M49470R01105MCC	SM042C105MHJ120	1.0 ±20%	4	200
	371	M49470R01125KCJ	SM052C125KHJ480	1.2 ±10%	5	200
	372	M49470R01125MCJ	SM052C125MHJ480	1.2 ±20%	5	200
		M49470R01125KCC	SM042C125KHJ240	1.2 ±10%	4	200
		M49470R01125MCC	SM042C125MHJ240	1.2 ±20%	4	200
	373	M49470R01155KCJ	SM052C155KHJ650	1.5 ±10%	5	200
	374	M49470R01155MCJ	SM052C155MHJ650	1.5 ±20%	5	200
		M49470R01155KCC	SM042C155KHJ230	1.5 ±10%	4	200
		M49470R01155MCC	SM042C155MHJ230	1.5 ±20%	4	200
	375	M49470R01185KCJ	SM042C185KHJ360	1.8 ±10%	4	200
	376	M49470R01185MCJ	SM042C185MHJ360	1.8 ±20%	4	200
	377	M49470R01225KCJ	SM042C225KHJ360	2.2 ±10%	4	200
	378	M49470R01225MCJ	SM042C225MHJ360	2.2 ±20%	4	200
	379	M49470R01275KCJ	SM042C275KHJ480	2.7 ±10%	4	200
	380	M49470R01275MCJ	SM042C275MHJ480	2.7 ±20%	4	200
	381	M49470R01335KCJ	SM042C335KHJ480	3.3 ±10%	4	200
	382	M49470R01335MCJ	SM042C335MHJ480	3.3 ±20%	4	200
	383	M49470R01395KCJ	SM042C395KHJ650	3.9 ±10%	4	200
	384	M49470R01395MCJ	SM042C395MHJ650	3.9 ±20%	4	200
		M49470R01395KCC	SM032C395KHJ240	3.9 ±10%	3	200
		M49470R01395MCC	SM032C395MHJ240	3.9 ±20%	3	200
	385	M49470R01475KCJ	SM032C475KHJ240	4.7 ±10%	3	200
	386	M49470R01475MCJ	SM032C475MHJ240	4.7 ±20%	3	200
	387	M49470R01565KCJ	SM032C565KHJ240	5.6 ±10%	3	200
	388	M49470R01565MCJ	SM032C565MHJ240	5.6 ±20%	3	200
	389	M49470R01685KCJ	SM032C685KHJ360	6.8 ±10%	3	200
	390	M49470R01685MCJ	SM032C685MHJ360	6.8 ±20%	3	200
	391	M49470R01825KCJ	SM032C825KHJ360	8.2 ±10%	3	200
	392	M49470R01825MCJ	SM032C825MHJ360	8.2 ±20%	3	200
	393	M49470R01106KCJ	SM032C106KHJ480	10 ±10%	3	200
	394	M49470R01106MCJ	SM032C106MHJ480	10 ±20%	3	200



SMPS Stacked MLC Capacitors

(SM Style) SM Military Styles MIL-PRF-49470



U.S. Preferred Styles

87106-	MIL-PRF-49470 PIN	AVX PART NUMBER	CAP (µF)	TOL	CASE CODE	VOLT (VDC)
395	M49470R01126KCJ	SM032C126KHJ650	12	±10%	3	200
396	M49470R01126MCJ	SM032C126MHJ650	12	±20%	3	200
	M49470R01126KCC	SM022C126KHJ240	12	±10%	2	200
	M49470R01126MCC	SM022C126MHJ240	12	±20%	2	200
397	M49470R01156KCJ	SM012C156KHJ360	15	±10%	1	200
398	M49470R01156MCJ	SM012C156MHJ360	15	±20%	1	200
	M49470R01156KCC	SM022C156KHJ240	15	±10%	2	200
	M49470R01156MCC	SM022C156MHJ240	15	±20%	2	200
399	M49470R01186KCJ	SM012C186KHJ480	18	±10%	1	200
400	M49470R01186MCJ	SM012C186MHJ480	18	±20%	1	200
	M49470R01186KCC	SM022C186KHJ360	18	±10%	2	200
	M49470R01186MCC	SM022C186MHJ360	18	±20%	2	200
401	M49470R01226KCJ	SM012C226KHJ650	22	±10%	1	200
402	M49470R01226MCJ	SM012C226MHJ650	22	±20%	1	200
	M49470R01226KCC	SM022C226KHJ360	22	±10%	2	200
	M49470R01226MCC	SM022C226MHJ360	22	±20%	2	200
403	M49470R01276KCJ	SM012C276KHJ650	27	±10%	1	200
404	M49470R01276MCJ	SM012C276MHJ650	27	±20%	1	200
	M49470R01276KCC	SM022C276KHJ480	27	±10%	2	200
	M49470R01276MCC	SM022C276MHJ480	27	±20%	2	200
405	M49470R01336KCJ	SM022C336KHJ480	33	±10%	2	200
406	M49470R01336MCJ	SM022C336MHJ480	33	±20%	2	200
407	M49470R01396KCJ	SM022C396KHJ650	39	±10%	2	200
408	M49470R01396MCJ	SM022C396MHJ650	39	±20%	2	200
409	M49470R01476KCJ	SM062C476KHJ240	47	±10%	6	200
410	M49470R01476MCJ	SM062C476MHJ240	47	±20%	6	200
411	M49470R01566KCJ	SM062C566KHJ360	56	±10%	6	200
412	M49470R01566MCJ	SM062C566MHJ360	56	±20%	6	200
413	M49470R01686KCJ	SM062C686KHJ360	68	±10%	6	200
414	M49470R01686MCJ	SM062C686MHJ360	68	±20%	6	200
415	M49470R01826KCJ	SM062C826KHJ480	82	±10%	6	200
416	M49470R01826MCJ	SM062C826MHJ480	82	±20%	6	200
417	M49470R01107KCJ	SM062C107KHJ650	100	±10%	6	200
418	M49470R01107MCJ	SM062C107MHJ650	100	±20%	6	200
419	M49470R01127KCJ	SM062C127KHJ650	120	±10%	6	200
420	M49470R01127MCJ	SM062C127MHJ650	120	±20%	6	200
421	M49470Q01154KEJ	SM057C154KHJ120	0.15	±10%	5	500
422	M49470Q01154MEJ	SM057C154MHJ120	0.15	±20%	5	500
423	M49470Q01184KEJ	SM057C184KHJ240	0.18	±10%	5	500
424	M49470Q01184MEJ	SM057C184MHJ240	0.18	±20%	5	500
425	M49470Q01224KEJ	SM057C224KHJ240	0.22	±10%	5	500
426	M49470Q01224MEJ	SM057C224MHJ240	0.22	±20%	5	500
427	M49470Q01274KEJ	SM057C274KHJ240	0.27	±10%	5	500
428	M49470Q01274MEJ	SM057C274MHJ240	0.27	±20%	5	500
429	M49470Q01334KEJ	SM057C334KHJ360	0.33	±10%	5	500
430	M49470Q01334MEJ	SM057C334MHJ360	0.33	±20%	5	500
431	M49470Q01394KEJ	SM057C394KHJ360	0.39	±10%	5	500
432	M49470Q01394MEJ	SM057C394MHJ360	0.39	±20%	5	500
433	M49470Q01474KEJ	SM057C474KHJ360	0.47	±10%	5	500
434	M49470Q01474MEJ	SM057C474MHJ360	0.47	±20%	5	500
435	M49470Q01564KEJ	SM057C564KHJ480	0.56	±10%	5	500
436	M49470Q01564MEJ	SM057C564MHJ480	0.56	±20%	5	500
	M49470Q01564KEC	SM047C564KHJ240	0.56	±10%	4	500
	M49470Q01564MEC	SM047C564MHJ240	0.56	±20%	4	500
437	M49470Q01684KEJ	SM057C684KHJ650	0.68	±10%	5	500
438	M49470Q01684MEJ	SM057C684MHJ650	0.68	±20%	5	500
	M49470Q01684KEC	SM047C684KHJ240	0.68	±10%	4	500
	M49470Q01684MEC	SM047C684MHJ240	0.68	±20%	4	500
439	M49470Q01824KEJ	SM047C824KHJ360	0.82	±10%	4	500
440	M49470Q01824MEJ	SM047C824MHJ360	0.82	±20%	4	500
441	M49470Q01105KEJ	SM047C105KHJ360	1.0	±10%	4	500
442	M49470Q01105MEJ	SM047C105MHJ360	1.0	±20%	4	500

87106-	MIL-PRF-49470 PIN	AVX PART NUMBER	CAP (µF)	TOL	CASE CODE	VOLT (VDC)
443	M49470Q01125KEJ	SM047C125KHJ360	1.2	±10%	4	500
444	M49470Q01125MEJ	SM047C125MHJ360	1.2	±20%	4	500
445	M49470Q01155KEJ	SM047C155KHJ480	1.5	±10%	4	500
446	M49470Q01155MEJ	SM047C155MHJ480	1.5	±20%	4	500
447	M49470Q01185KEJ	SM047C185KHJ650	1.8	±10%	4	500
448	M49470Q01185MEJ	SM047C185MHJ650	1.8	±20%	4	500
	M49470Q01185KEC	SM037C185KHJ240	1.8	±10%	3	500
	M49470Q01185MEC	SM037C185MHJ240	1.8	±20%	3	500
449	M49470Q01225KEJ	SM037C225KHJ240	2.2	±10%	3	500
450	M49470Q01225MEJ	SM037C225MHJ240	2.2	±20%	3	500
451	M49470Q01275KEJ	SM037C275KHJ360	2.7	±10%	3	500
452	M49470Q01275MEJ	SM037C275MHJ360	2.7	±20%	3	500
453	M49470Q01335KEJ	SM037C335KHJ360	3.3	±10%	3	500
454	M49470Q01335MEJ	SM037C335MHJ360	3.3	±20%	3	500
455	M49470Q01395KEJ	SM037C395KHJ360	3.9	±10%	3	500
456	M49470Q01395MEJ	SM037C395MHJ360	3.9	±20%	3	500
457	M49470Q01475KEJ	SM037C475KHJ480	4.7	±10%	3	500
458	M49470Q01475MEJ	SM037C475MHJ480	4.7	±20%	3	500
459	M49470Q01565KEJ	SM037C565KHJ650	5.6	±10%	3	500
460	M49470Q01565MEJ	SM037C565MHJ650	5.6	±20%	3	500
	M49470Q01565KEC	SM027C565KHJ240	5.6	±10%	2	500
	M49470Q01565MEC	SM027C565MHJ240	5.6	±20%	2	500
461	M49470Q01685KEJ	SM017C685KHJ480	6.8	±10%	1	500
462	M49470Q01685MEJ	SM017C685MHJ480	6.8	±20%	1	500
	M49470Q01685KEC	SM027C685KHJ240	6.8	±10%	2	500
	M49470Q01685MEC	SM027C685MHJ240	6.8	±20%	2	500
463	M49470Q01825KEJ	SM017C825KHJ480	8.2	±10%	1	500
464	M49470Q01825MEJ	SM017C825MHJ480	8.2	±20%	1	500
	M49470Q01825KEC	SM027C825KHJ360	8.2	±10%	2	500
	M49470Q01825MEC	SM027C825MHJ360	8.2	±20%	2	500
465	M49470Q01106KEJ	SM017C106KHJ480	10	±10%	1	500
466	M49470Q01106MEJ	SM017C106MHJ480	10	±20%	1	500
	M49470Q01106KEC	SM027C106KHJ360	10	±10%	2	500
	M49470Q01106MEC	SM027C106MHJ360	10	±20%	2	500
467	M49470Q01126KEJ	SM017C126KHJ650	12	±10%	1	500
468	M49470Q01126MEJ	SM017C126MHJ650	12	±10%	1	500
	M49470Q01126MEC	SM027C126MHJ480	12	±20%	2	500
	M49470Q01126MEC	SM027C126MHJ480	12	±20%	2	500
469	M49470Q01156KEJ	SM027C156KHJ650	15	±10%	2	500
470	M49470Q01156MEJ	SM027C156MHJ650	15	±20%	2	500
471	M49470Q01186KEJ	SM027C186KHJ650	18	±10%	2	500
472	M49470Q01186MEJ	SM027C186MHJ650	18	±20%	2	500
473	M49470Q01226KEJ	SM067C226KHJ360	22	±10%	6	500
474	M49470Q01226MEJ	SM067C226MHJ360	22	±20%	6	500
475	M49470Q01276KEJ	SM067C276KHJ360	27	±10%	6	500
476	M49470Q01276MEJ	SM067C276MHJ360	27	±20%	6	500
477	M49470Q01336KEJ	SM067C336KHJ480	33	±10%	6	500
478	M49470Q01336MEJ	SM067C336MHJ480	33	±20%	6	500
479	M49470Q01396KEJ	SM067C396KHJ650	39	±10%	6	500
480	M49470Q01396MEJ	SM067C396MHJ650	39	±20%	6	500



SMPS Stacked MLC Capacitors



(SM Style) SM Military Styles DSCC Dwg. #87106 & #88011 U.S. Preferred Styles

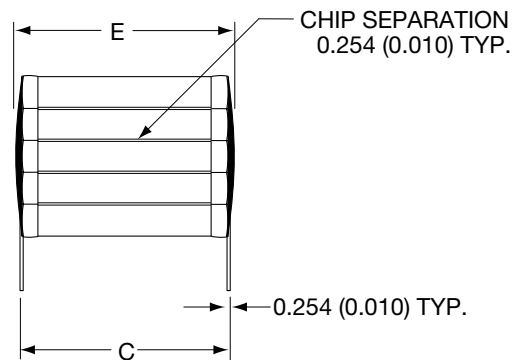
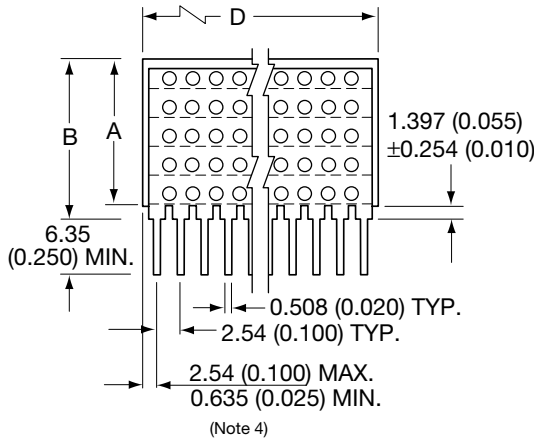

“N” STYLE LEADS

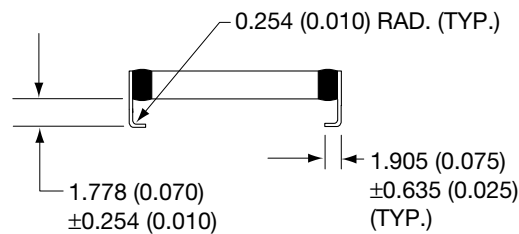
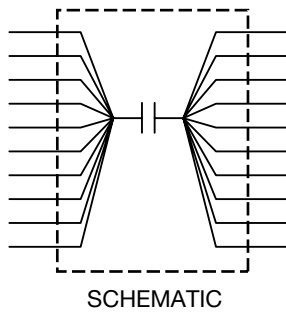

“J” STYLE LEADS

DIMENSIONS

millimeters (inches)

Case Code	A (max.) (See Note 2)	B (max.) (See Note 2)	C ±.635 (±0.025)	D ±.635 (±0.025)	E (max.)	No. of Leads per side
1	16.5 (0.650)	18.2 (0.715)	11.4 (0.450)	52.1 (2.050)	12.7 (0.500)	20
2	16.5 (0.650)	18.2 (0.715)	20.3 (0.800)	38.4 (1.510)	22.1 (0.870)	15
3	16.5 (0.650)	18.2 (0.715)	11.4 (0.450)	26.7 (1.050)	12.7 (0.500)	10
4	16.5 (0.650)	18.2 (0.715)	10.2 (0.400)	10.2 (0.400)	11.2 (0.440)	4
5	16.5 (0.650)	18.2 (0.715)	6.35 (0.250)	6.35 (0.250)	7.62 (0.300)	3
6	16.5 (0.650)	18.2 (0.715)	31.8 (1.250)	52.1 (2.050)	34.3 (1.350)	20

NOTES:

1. Unless otherwise specified, tolerances 0.254 (±0.010).
2. “A” dimensions are maximum (see tables on pages 96 thru 99 for specific part number dimensions).
3. “N” straight leads; “J” leads formed in.
4. For case code 5, dimensions shall be 2.54 (0.100) maximum, 0.305 (0.012) minimum.



SMPS Stacked MLC Capacitors



(SM Style) SM Military Styles DSCC Dwg. #87106 & #88011

U.S. Preferred Styles

Ordering Information

Part Number: The complete part number shall be as follows:

X7R: 87106 XXX

Drawing number

Dash number
(see list)

Ordering Data. The contract or purchase order should specify the following:

- Complete part number.
- Requirements for delivery of one copy of the quality conformance inspection data with each shipment of parts by the manufacturer.
- Whether the manufacturer performs the group B tests, or provides certification of compliance with group B requirements.
- Requirements for notification of change of products to acquiring activity, if applicable.
- Requirements for packaging and packing.

Source of Supply.

Vendor CAGE number	Vendor name and address
96095	Olean Advanced Products A Division of AVX Corporation 1695 Seneca Avenue Olean, NY 14760

Performance Characteristics

Operating Temperature Range. The operating temperature range shall be -55°C to +125°C.

Electrical Characteristics.

Rated Voltage. See tables on pages 96-99.

Capacitance. Measured in accordance with method 305 of MIL-STD-202 (1KHz at 1.0Vrms, open circuit voltage, at +25°C).

Dissipation Factor (+25°C). X7R: Dissipation factor shall be 2.5 percent maximum (measured under the same conditions as capacitance.) C0G: Dissipation factor shall be 0.15 percent maximum.

Temperature Coefficient.

DSCC Dwg.	Bias = 0 volt	Bias = rated voltage
88011 All Voltages	0±30 ppm/°C	0±30 ppm/°C
87106 50 WVDC and 100 WVDC	±15%	+15, -25%
87106 200 WVDC	±15%	+15, -40%
87106 500 WVDC	±15%	+15, -50%

Insulation Resistance.

At +25°C, rated voltage: 100K MΩ or 1,000 MΩ-μF, whichever is less.

At +125°C, rated voltage: 10K MΩ or 100 MΩ-μF, whichever is less.

Dielectric Withstanding Voltage. Dielectric withstanding voltage shall be 250 percent of rated voltage except 500V rated parts at 150 percent of rated voltage.

Capacitance Tolerance. J = ±5 percent, K = ±10 percent, M = ±20 percent.

Solderability of Terminals. In accordance with MIL-PRF-49470.

Resistance to Soldering Heat. In accordance with MIL-STD-202, method 210, procedure 2, condition B.

Shock. In accordance with MIL-PRF-49470.

Immersion Cycling. In accordance with MIL-PRF-49470.

Moisture Resistance. In accordance with MIL-PRF-49470.

Life. Life shall be 200 percent of rated voltage except 500V rated parts at 120 percent of rated voltage applied at +125°C for 1,000 hours.

Thermal Shock. MIL-STD-202, method 107, test condition A, except high temperature is +125°C.

Voltage Conditioning. In accordance with MIL-PRF-49470, except 500V rated parts at 120 percent of rated voltage at +125°C.

Terminal Strength. MIL-STD-202, method 211, condition B, except that each lead shall be bent away from the body 90 degrees from the original position and back, two bends.

Marking. Marking shall be in accordance with MIL-STD-1285, except the part number shall be as specified in paragraph 1.2 of 87106, or 88011 with the manufacturer's name or code and date code minimum, except case sizes 4 and 5 shall be marked with coded cap and tolerance minimum. Full marking shall be included on the package.



SMPS Stacked MLC Capacitors

(SM Style) DSCC #87106 and #88011



U.S. Preferred Styles

Table II. Group A inspection.

Inspection	Requirement paragraph of MIL-PRF-49470	Test method paragraph of MIL-PRF-49470	Sampling procedure
Subgroup 1 Thermal shock and voltage conditioning <u>1/</u>	3.9	4.8.5	100% inspection
Subgroup 2 Visual and mechanical examination: Material Physical dimensions Interface requirements (other than physical dimensions) Marking <u>2/</u> Workmanship	3.4 3.1 3.5 and 3.5.1 3.28 3.30	4.8.4	13 samples 0 failures

1/ Post checks are required (see paragraph 3.9 of MIL-PRF-49470).

2/ Marking defects are based on visual examination only. Any subsequent electrical defects shall not be used as a basis for determining marking defects.

Table III. Group B inspection. 1/

Inspection	Requirement paragraph of MIL-PRF-49470	Test method paragraph of MIL-PRF-49470	Number of sample units to be inspected	Number of defectives permitted <u>2/</u>	
Subgroup 1 <u>3/</u> Temperature coefficient Resistance to solvents <u>5/</u> <u>6/</u> Immersion Terminal strength <u>5/</u>	<u>4/</u> 3.23 3.18 3.24	<u>4/</u> 4.8.20 4.8.15 4.8.10	12	1	<u>6/</u> 1
Subgroup 2 Resistance to soldering heat Moisture resistance	3.20 3.21	4.8.17 4.8.18	12	1	
Subgroup 3 Marking legibility (laser marking only)	3.28.1	4.8.4.1	6	1	
Subgroup 4 Solderability	3.15	4.8.12	3	0	
Subgroup 5 Life	3.26	4.8.22	5 minimum per case code	0	

1/ Unless otherwise specified herein, when necessary, mounting of group B samples shall be at the discretion of the manufacturer.

2/ A sample unit having one or more defects shall be charged as a single defective.

3/ Order of tests is at discretion of manufacturer.

4/ See 3.2.3 of DSCC 87106.

5/ Sample size shall be 3 pieces with zero defectives permitted.

6/ Total of one defect allowed for combination of subgroup 1, subgroup 2, and subgroup 3 inspections.

SMPS Stacked MLC Capacitors



(SM Style) SM Military Styles DSCC Dwg. #87106 (X7R)

U.S. Preferred Styles

Electrical characteristics

DSCC Dwg. 87106-	Cap. Value (µF)	Cap. Tol.	Case Code	Lead Style	Max. A Dimension mm (inches)
50V					
001	1.0	K	5	N	3.05 (0.120)
002	1.0	M	5	N	3.05 (0.120)
241	1.0	K	5	J	3.05 (0.120)
242	1.0	M	5	J	3.05 (0.120)
003	1.2	K	5	N	3.05 (0.120)
004	1.2	M	5	N	3.05 (0.120)
243	1.2	K	5	J	3.05 (0.120)
244	1.2	M	5	J	3.05 (0.120)
005	1.5	K	5	N	6.10 (0.240)
006	1.5	M	5	N	6.10 (0.240)
245	1.5	K	5	J	6.10 (0.240)
246	1.5	M	5	J	6.10 (0.240)
007	1.8	K	5	N	6.10 (0.240)
008	1.8	M	5	N	6.10 (0.240)
247	1.8	K	5	J	6.10 (0.240)
248	1.8	M	5	J	6.10 (0.240)
009	2.2	K	5	N	6.10 (0.240)
010	2.2	M	5	N	6.10 (0.240)
249	2.2	K	5	J	6.10 (0.240)
250	2.2	M	5	J	6.10 (0.240)
011	2.7	K	5	N	9.14 (0.360)
012	2.7	M	5	N	9.14 (0.360)
251	2.7	K	5	J	9.14 (0.360)
252	2.7	M	5	J	9.14 (0.360)
013	3.3	K	5	N	9.14 (0.360)
014	3.3	M	5	N	9.14 (0.360)
253	3.3	K	5	J	9.14 (0.360)
254	3.3	M	5	J	9.14 (0.360)
015	3.9	K	5	N	12.2 (0.480)
016	3.9	M	5	N	12.2 (0.480)
255	3.9	K	5	J	12.2 (0.480)
256	3.9	M	5	J	12.2 (0.480)
017	4.7	K	5	N	12.2 (0.480)
018	4.7	M	5	N	12.2 (0.480)
257	4.7	K	5	J	12.2 (0.480)
258	4.7	M	5	J	12.2 (0.480)
019	5.6	K	5	N	16.5 (0.650)
020	5.6	M	5	N	16.5 (0.650)
259	5.6	K	5	J	16.5 (0.650)
260	5.6	M	5	J	16.5 (0.650)
223	6.8	K	4	N	9.14 (0.360)
224	6.8	M	4	N	9.14 (0.360)
261	6.8	K	4	J	9.14 (0.360)
262	6.8	M	4	J	9.14 (0.360)
021	8.2	K	4	N	9.14 (0.360)
022	8.2	M	4	N	9.14 (0.360)
263	8.2	K	4	J	9.14 (0.360)
264	8.2	M	4	J	9.14 (0.360)
023	10	K	4	N	12.2 (0.480)
024	10	M	4	N	12.2 (0.480)
265	10	K	4	J	12.2 (0.480)
266	10	M	4	J	12.2 (0.480)
025	12	K	4	N	12.2 (0.480)
026	12	M	4	N	12.2 (0.480)
267	12	K	4	J	12.2 (0.480)
268	12	M	4	J	12.2 (0.480)
027	15	K	4	N	16.5 (0.650)
028	15	M	4	N	16.5 (0.650)
269	15	K	4	J	16.5 (0.650)
270	15	M	4	J	16.5 (0.650)
029	18	K	3	N	6.10 (0.240)
030	18	M	3	N	6.10 (0.240)
271	18	K	3	J	6.10 (0.240)

DSCC Dwg. 87106-	Cap. Value (µF)	Cap. Tol.	Case Code	Lead Style	Max. A Dimension mm (inches)
50V					
272	18	M	3	J	6.10 (0.240)
272	18	M	3	J	6.10 (0.240)
031	22	K	3	N	9.14 (0.360)
032	22	M	3	N	9.14 (0.360)
273	22	K	3	J	9.14 (0.360)
274	22	M	3	J	9.14 (0.360)
033	27	K	3	N	9.14 (0.360)
034	27	M	3	N	9.14 (0.360)
275	27	K	3	J	9.14 (0.360)
276	27	M	3	J	9.14 (0.360)
035	33	K	3	N	9.14 (0.360)
036	33	M	3	N	9.14 (0.360)
277	33	K	3	J	9.14 (0.360)
278	33	M	3	J	9.14 (0.360)
037	39	K	3	N	12.2 (0.480)
038	39	M	3	N	12.2 (0.480)
279	39	K	3	J	12.2 (0.480)
280	39	M	3	J	12.2 (0.480)
039	47	K	3	N	16.5 (0.650)
040	47	M	3	N	16.5 (0.650)
281	47	K	3	J	16.5 (0.650)
282	47	M	3	J	16.5 (0.650)
225	56	K	1	N	9.14 (0.360)
226	56	M	1	N	9.14 (0.360)
283	56	K	1	J	9.14 (0.360)
284	56	M	1	J	9.14 (0.360)
041	68	K	1	N	12.2 (0.480)
042	68	M	1	N	12.2 (0.480)
285	68	K	1	J	12.2 (0.480)
286	68	M	1	J	12.2 (0.480)
043	82	K	1	N	12.2 (0.480)
044	82	M	1	N	12.2 (0.480)
287	82	K	1	J	12.2 (0.480)
288	82	M	1	J	12.2 (0.480)
045	100	K	1	N	16.5 (0.650)
046	100	M	1	N	16.5 (0.650)
289	100	K	1	J	16.5 (0.650)
290	100	M	1	J	16.5 (0.650)
227	120	K	2	N	12.2 (0.480)
228	120	M	2	N	12.2 (0.480)
291	120	K	2	J	12.2 (0.480)
292	120	M	2	J	12.2 (0.480)
047	150	K	2	N	16.5 (0.650)
048	150	M	2	N	16.5 (0.650)
293	150	K	2	J	16.5 (0.650)
294	150	M	2	J	16.5 (0.650)
049	180	K	6	N	12.2 (0.480)
050	180	M	6	N	12.2 (0.480)
295	180	K	6	J	12.2 (0.480)
296	180	M	6	J	12.2 (0.480)
051	220	K	6	N	12.2 (0.480)
052	220	M	6	N	12.2 (0.480)
297	220	K	6	J	12.2 (0.480)
298	220	M	6	J	12.2 (0.480)
053	270	K	6	N	16.5 (0.650)
054	270	M	6	N	16.5 (0.650)
299	270	K	6	J	16.5 (0.650)
300	270	M	6	J	16.5 (0.650)

DSCC Dwg. 87106-	Cap. Value (µF)	Cap. Tol.	Case Code	Lead Style	Max. A Dimension mm (inches)
100V					
055	.68	K	5	N	3.05 (0.120)
056	.68	M	5	N	3.05 (0.120)
301	.68	K	5	J	3.05 (0.120)
302	.68	M	5	J	3.05 (0.120)
057	.82	K	5	N	6.10 (0.240)
058	.82	M	5	N	6.10 (0.240)
303	.82	K	5	J	6.10 (0.240)
304	.82	M	5	J	6.10 (0.240)
059	1.0	K	5	N	6.10 (0.240)
060	1.0	M	5	N	6.10 (0.240)
305	1.0	K	5	J	6.10 (0.240)
306	1.0	M	5	J	6.10 (0.240)
061	1.2	K	5	N	6.10 (0.240)
062	1.2	M	5	N	6.10 (0.240)
307	1.2	K	5	J	6.10 (0.240)
308	1.2	M	5	J	6.10 (0.240)
063	1.5	K	5	N	9.14 (0.360)
064	1.5	M	5	N	9.14 (0.360)
309	1.5	K	5	J	9.14 (0.360)
310	1.5	M	5	J	9.14 (0.360)
065	1.8	K	5	N	9.14 (0.360)
066	1.8	M	5	N	9.14 (0.360)
311	1.8	K	5	J	9.14 (0.360)
312	1.8	M	5	J	9.14 (0.360)
067	2.2	K	5	N	12.2 (0.480)
068	2.2	M	5	N	12.2 (0.480)
313	2.2	K	5	J	12.2 (0.480)
314	2.2	M	5	J	12.2 (0.480)
069	2.7	K	5	N	12.2 (0.480)
070	2.7	M	5	N	12.2 (0.480)
315	2.7	K	5	J	12.2 (0.480)
316	2.7	M	5	J	12.2 (0.480)
071	3.3	K	5	N	16.5 (0.650)
072	3.3	M	5	N	16.5 (0.650)
317	3.3	K	5	J	16.5 (0.650)
318	3.3	M	5	J	16.5 (0.650)
073	3.9	K	4	N	9.14 (0.360)
074	3.9	M	4	N	9.14 (0.360)
319	3.9	K	4	J	9.14 (0.360)
320	3.9	M	4	J	9.14 (0.360)
075	4.7	K	4	N	9.14 (0.360)
076	4.7	M	4	N	9.14 (0.360)
321	4.7	K	4	J	9.14 (0.360)
322	4.7	M	4	J	9.14 (0.360)
077	5.6	K	4	N	12.2 (0.480)
078	5.6	M	4	N	12.2 (0.480)
323	5.6	K	4	J	12.2 (0.480)
324	5.6	M	4	J	12.2 (0.480)
079	6.8	K	4	N	12.2 (0.480)
080	6.8	M	4	N	12.2 (0.480)
325	6.8	K	4	J	12.2 (0.480)
326	6.8	M	4	J	12.2 (0.480)
081	8.2	K	4	N	16.5 (0.650)
082	8.2	M	4	N	16.5 (0.650)
327	8.2	K	4	J	16.5 (0.650)
328	8.2	M	4	J	16.5 (0.650)
229	10	K	3	N	6.10 (0.240)
230	10	M	3	N	6.10 (0.240)
329	10	K	3	J	6.10 (0.240)
330	10	M	3	J	6.10 (0.240)
083	12	K	3	N	6.10 (0.240)
084	12	M	3	N	6.10 (0.240)
331	12	K	3	J	6.10 (0.240)
332	12	M	3	J	6.10 (0.240)



SMPS Stacked MLC Capacitors



(SM Style) SM Military Styles DSCC Dwg. #87106 (X7R)

U.S. Preferred Styles

Electrical characteristics

DSCC Dwg. 87106-	Cap. Value (µF)	Cap. Tol.	Case Code	Lead Style	Max. A Dimension mm (inches)
100V					
085	15	K	3	N	9.14 (0.360)
086	15	M	3	N	9.14 (0.360)
333	15	K	3	J	9.14 (0.360)
334	15	M	3	J	9.14 (0.360)
087	18	K	3	N	9.14 (0.360)
088	18	M	3	N	9.14 (0.360)
335	18	K	3	J	9.14 (0.360)
336	18	M	3	J	9.14 (0.360)
089	22	K	3	N	12.2 (0.480)
090	22	M	3	N	12.2 (0.480)
337	22	M	3	K	12.2 (0.480)
338	22	M	3	J	12.2 (0.480)
091	27	K	3	N	16.5 (0.650)
092	27	M	3	N	16.5 (0.650)
339	27	K	3	J	16.5 (0.650)
340	27	M	3	J	16.5 (0.650)
093	33	K	1	N	9.14 (0.360)
094	33	M	1	N	9.14 (0.360)
341	33	K	1	J	9.14 (0.360)
342	33	M	1	J	9.14 (0.360)
095	39	K	1	N	12.2 (0.480)
096	39	M	1	N	12.2 (0.480)
343	39	K	1	J	12.2 (0.480)
344	39	M	1	J	12.2 (0.480)
097	47	K	1	N	12.2 (0.480)
098	47	M	1	N	12.2 (0.480)
345	47	K	1	J	12.2 (0.480)
346	47	M	1	J	12.2 (0.480)
099	56	K	1	N	16.5 (0.650)
100	56	M	1	N	16.5 (0.650)
347	56	K	1	J	16.5 (0.650)
348	56	M	1	J	16.5 (0.650)
101	68	K	2	N	12.2 (0.480)
102	68	M	2	N	12.2 (0.480)
349	68	K	2	J	12.2 (0.480)
350	68	M	2	J	12.2 (0.480)
103	82	K	2	N	16.5 (0.650)
104	82	M	2	N	16.5 (0.650)
351	82	K	2	J	16.5 (0.650)
352	82	M	2	J	16.5 (0.650)
105	100	K	6	N	9.14 (0.360)
106	100	M	6	N	9.14 (0.360)
353	100	K	6	J	9.14 (0.360)
354	100	M	6	J	9.14 (0.360)
107	120	K	6	N	9.14 (0.360)
108	120	M	6	N	9.14 (0.360)
355	120	K	6	J	9.14 (0.360)
356	120	M	6	J	9.14 (0.360)
109	150	K	6	N	12.2 (0.480)
110	150	M	6	N	12.2 (0.480)
357	150	K	6	J	12.2 (0.480)
358	150	M	6	J	12.2 (0.480)
111	180	K	6	N	16.5 (0.650)
112	180	M	6	N	16.5 (0.650)
359	180	K	6	J	16.5 (0.650)
360	180	M	6	J	16.5 (0.650)

DSCC Dwg. 87106-	Cap. Value (µF)	Cap. Tol.	Case Code	Lead Style	Max. A Dimension mm (inches)
200V					
113	.47	K	5	N	6.10 (0.240)
114	.47	M	5	N	6.10 (0.240)
361	.47	K	5	J	6.10 (0.240)
362	.47	M	5	J	6.10 (0.240)
115	.56	K	5	N	6.10 (0.240)
116	.56	M	5	N	6.10 (0.240)
363	.56	K	5	J	6.10 (0.240)
364	.56	M	5	J	6.10 (0.240)
117	.68	K	5	N	9.14 (0.360)
118	.68	M	5	N	9.14 (0.360)
365	.68	K	5	J	9.14 (0.360)
366	.68	M	5	J	9.14 (0.360)
119	.82	K	5	N	9.14 (0.360)
120	.82	M	5	N	9.14 (0.360)
367	.82	M	5	J	9.14 (0.360)
368	.82	M	5	J	9.14 (0.360)
121	1.0	K	5	N	12.2 (0.480)
122	1.0	M	5	N	12.2 (0.480)
369	1.0	K	5	J	12.2 (0.480)
370	1.0	M	5	J	12.2 (0.480)
123	1.2	K	5	N	12.2 (0.480)
124	1.2	M	5	N	12.2 (0.480)
371	1.2	K	5	J	12.2 (0.480)
372	1.2	M	5	J	12.2 (0.480)
125	1.5	K	5	N	16.5 (0.650)
126	1.5	M	5	N	16.5 (0.650)
373	1.5	K	5	J	16.5 (0.650)
374	1.5	M	5	J	16.5 (0.650)
127	1.8	K	4	N	9.14 (0.360)
128	1.8	M	4	N	9.14 (0.360)
375	1.8	K	4	J	9.14 (0.360)
376	1.8	M	4	J	9.14 (0.360)
129	2.2	K	4	N	9.14 (0.360)
130	2.2	M	4	N	9.14 (0.360)
377	2.2	K	4	J	9.14 (0.360)
378	2.2	M	4	J	9.14 (0.360)
131	2.7	K	4	N	12.2 (0.480)
132	2.7	M	4	N	12.2 (0.480)
379	2.7	K	4	J	12.2 (0.480)
380	2.7	M	4	J	12.2 (0.480)
133	3.3	K	4	N	12.2 (0.480)
134	3.3	M	4	N	12.2 (0.480)
381	3.3	K	4	J	12.2 (0.480)
382	3.3	M	4	J	12.2 (0.480)
135	3.9	K	4	N	16.5 (0.650)
136	3.9	M	4	N	16.5 (0.650)
383	3.9	K	4	J	16.5 (0.650)
384	3.9	M	4	J	16.5 (0.650)
137	4.7	K	3	N	6.10 (0.240)
138	4.7	M	3	N	6.10 (0.240)
385	4.7	K	3	J	6.10 (0.240)
386	4.7	M	3	J	6.10 (0.240)
139	5.6	K	3	N	6.10 (0.240)
140	5.6	M	3	N	6.10 (0.240)
387	5.6	K	3	J	6.10 (0.240)
388	5.6	M	3	J	6.10 (0.240)
141	6.8	K	3	N	9.14 (0.360)
142	6.8	M	3	N	9.14 (0.360)
389	6.8	K	3	J	9.14 (0.360)
390	6.8	M	3	J	9.14 (0.360)
143	8.2	K	3	N	9.14 (0.360)
144	8.2	M	3	N	9.14 (0.360)
391	8.2	K	3	J	9.14 (0.360)
392	8.2	M	3	J	9.14 (0.360)

DSCC Dwg. 87106-	Cap. Value (µF)	Cap. Tol.	Case Code	Lead Style	Max. A Dimension mm (inches)
200V					
145	10	K	3	N	12.2 (0.480)
146	10	M	3	N	12.2 (0.480)
393	10	K	3	J	12.2 (0.480)
394	10	M	3	J	12.2 (0.480)
147	12	K	3	N	16.5 (0.650)
148	12	M	3	N	16.5 (0.650)
395	12	K	3	J	16.5 (0.650)
396	12	M	3	J	16.5 (0.650)
149	15	K	1	N	9.14 (0.360)
150	15	M	1	N	9.14 (0.360)
397	15	K	1	J	9.14 (0.360)
398	15	M	1	J	9.14 (0.360)
151	18	K	1	N	12.2 (0.480)
152	18	M	1	N	12.2 (0.480)
399	18	K	1	J	12.2 (0.480)
400	18	M	1	J	12.2 (0.480)
153	22	K	1	N	16.5 (0.650)
154	22	M	1	N	16.5 (0.650)
401	22	K	1	J	16.5 (0.650)
402	22	M	1	J	16.5 (0.650)
155	27	K	1	N	16.5 (0.650)
156	27	M	1	N	16.5 (0.650)
403	27	K	1	J	16.5 (0.650)
404	27	M	1	J	16.5 (0.650)
157	33	K	2	N	12.2 (0.480)
158	33	M	2	N	12.2 (0.480)
405	33	K	2	J	12.2 (0.480)
406	33	M	2	J	12.2 (0.480)
159	39	K	2	N	16.5 (0.650)
160	39	M	2	N	16.5 (0.650)
407	39	K	2	J	16.5 (0.650)
408	39	M	2	J	16.5 (0.650)
161	47	K	6	N	6.10 (0.240)
162	47	M	6	N	6.10 (0.240)
409	47	K	6	J	6.10 (0.240)
410	47	M	6	J	6.10 (0.240)
163	56	K	6	N	9.14 (0.360)
164	56	M	6	N	9.14 (0.360)
411	56	K	6	J	9.14 (0.360)
412	56	M	6	J	9.14 (0.360)
165	68	K	6	N	9.14 (0.360)
166	68	M	6	N	9.14 (0.360)
413	68	K	6	J	9.14 (0.360)
414	68	M	6	J	9.14 (0.360)
167	82	K	6	N	12.2 (0.480)
168	82	M	6	N	12.2 (0.480)
415	82	K	6	J	12.2 (0.480)
416	82	M	6	J	12.2 (0.480)
169	100	K	6	N	16.5 (0.650)
170	100	M	6	N	16.5 (0.650)
417	100	K	6	J	16.5 (0.650)
418	100	M	6	J	16.5 (0.650)
171	120	K	6	N	16.5 (0.650)
172	120	M	6	N	16.5 (0.650)
419	120	K	6	J	16.5 (0.650)
420	120	M	6	J	16.5 (0.650)



SMPS Stacked MLC Capacitors

(SM Style) SM Military Styles DSCC Dwg. #87106 (X7R)



U.S. Preferred Styles

Electrical characteristics

DSCC Dwg. 87106-	Cap. Value (µF)	Cap. Tol.	Case Code	Lead Style	Max. A Dimension mm (inches)
500V					
173	.15	K	5	N	3.05 (0.120)
174	.15	M	5	N	3.05 (0.120)
421	.15	K	5	J	3.05 (0.120)
422	.15	M	5	J	3.05 (0.120)
175	.18	K	5	N	6.10 (0.240)
176	.18	M	5	N	6.10 (0.240)
423	.18	K	5	J	6.10 (0.240)
424	.18	M	5	J	6.10 (0.240)
177	.22	K	5	N	6.10 (0.240)
178	.22	M	5	N	6.10 (0.240)
425	.22	K	5	J	6.10 (0.240)
426	.22	M	5	J	6.10 (0.240)
179	.27	K	5	N	6.10 (0.240)
180	.27	M	5	N	6.10 (0.240)
427	.27	K	5	J	6.10 (0.240)
428	.27	M	5	J	6.10 (0.240)
181	.33	K	5	N	9.14 (0.360)
182	.33	M	5	N	9.14 (0.360)
429	.33	K	5	J	9.14 (0.360)
430	.33	M	5	J	9.14 (0.360)
183	.39	K	5	N	9.14 (0.360)
184	.39	M	5	N	9.14 (0.360)
431	.39	K	5	J	9.14 (0.360)
432	.39	M	5	J	9.14 (0.360)
185	.47	K	5	N	9.14 (0.360)
186	.47	M	5	N	9.14 (0.360)
433	.47	K	5	J	9.14 (0.360)
434	.47	M	5	J	9.14 (0.360)
187	.56	K	5	N	12.2 (0.480)
188	.56	M	5	N	12.2 (0.480)
435	.56	K	5	J	12.2 (0.480)
436	.56	M	5	J	12.2 (0.480)
189	.68	K	5	N	16.5 (0.650)
190	.68	M	5	N	16.5 (0.650)
437	.68	K	5	J	16.5 (0.650)
438	.68	M	5	J	16.5 (0.650)
231	.82	K	4	N	9.14 (0.360)
232	.82	M	4	N	9.14 (0.360)
439	.82	K	4	J	9.14 (0.360)
440	.82	M	4	J	9.14 (0.360)
191	1.0	K	4	N	9.14 (0.360)
192	1.0	M	4	N	9.14 (0.360)
441	1.0	K	4	J	9.14 (0.360)
442	1.0	M	4	J	9.14 (0.360)
193	1.2	K	4	N	9.14 (0.360)
194	1.2	M	4	N	9.14 (0.360)
443	1.2	K	4	J	9.14 (0.360)
444	1.2	M	4	J	9.14 (0.360)
195	1.5	K	4	N	12.2 (0.480)
196	1.5	M	4	N	12.2 (0.480)
445	1.5	K	4	J	12.2 (0.480)
446	1.5	M	4	J	12.2 (0.480)
197	1.8	K	4	N	16.5 (0.650)
198	1.8	M	4	N	16.5 (0.650)
447	1.8	K	4	J	16.5 (0.650)
448	1.8	M	4	J	16.5 (0.650)
233	2.2	K	3	N	6.10 (0.240)
234	2.2	M	3	N	6.10 (0.240)
449	2.2	K	3	J	6.10 (0.240)
450	2.2	M	3	J	6.10 (0.240)
199	2.7	K	3	N	9.14 (0.360)
200	2.7	M	3	N	9.14 (0.360)
451	2.7	K	3	J	9.14 (0.360)
452	2.7	M	3	J	9.14 (0.360)

DSCC Dwg. 87106-	Cap. Value (µF)	Cap. Tol.	Case Code	Lead Style	Max. A Dimension mm (inches)
500V					
201	3.3	K	3	N	9.14 (0.360)
202	3.3	M	3	N	9.14 (0.360)
453	3.3	K	3	J	9.14 (0.360)
454	3.3	M	3	J	9.14 (0.360)
203	3.9	K	3	N	9.14 (0.360)
204	3.9	M	3	N	9.14 (0.360)
455	3.9	K	3	J	9.14 (0.360)
456	3.9	M	3	J	9.14 (0.360)
205	4.7	K	3	N	12.2 (0.480)
206	4.7	M	3	N	12.2 (0.480)
457	4.7	K	3	J	12.2 (0.480)
458	4.7	M	3	J	12.2 (0.480)
207	5.6	K	3	N	16.5 (0.650)
208	5.6	M	3	N	16.5 (0.650)
459	5.6	K	3	J	16.5 (0.650)
460	5.6	M	3	J	16.5 (0.650)
235	6.8	K	1	N	12.2 (0.480)
236	6.8	M	1	N	12.2 (0.480)
461	6.8	K	1	J	12.2 (0.480)
462	6.8	M	1	J	12.2 (0.480)
209	8.2	K	1	N	12.2 (0.480)
210	8.2	M	1	N	12.2 (0.480)
463	8.2	K	1	J	12.2 (0.480)
464	8.2	M	1	J	12.2 (0.480)
211	10	K	1	N	12.2 (0.480)
212	10	M	1	N	12.2 (0.480)
465	10	K	1	J	12.2 (0.480)
466	10	M	1	J	12.2 (0.480)
213	12	K	1	N	16.5 (0.650)
214	12	M	1	N	16.5 (0.650)
467	12	K	1	J	16.5 (0.650)
468	12	M	1	J	16.5 (0.650)
237	15	K	2	N	16.5 (0.650)
238	15	M	2	N	16.5 (0.650)
469	15	K	2	J	16.5 (0.650)
470	15	M	2	J	16.5 (0.650)
215	18	K	2	N	16.5 (0.650)
216	18	M	2	N	16.5 (0.650)
471	18	K	2	J	16.5 (0.650)
472	18	M	2	J	16.5 (0.650)
239	22	K	6	N	9.14 (0.360)
240	22	M	6	N	9.14 (0.360)
473	22	K	6	J	9.14 (0.360)
474	22	M	6	J	9.14 (0.360)
217	27	K	6	N	9.14 (0.360)
218	27	M	6	N	9.14 (0.360)
475	27	K	6	J	9.14 (0.360)
476	27	M	6	J	9.14 (0.360)
219	33	K	6	N	12.2 (0.480)
220	33	M	6	N	12.2 (0.480)
477	33	K	6	J	12.2 (0.480)
478	33	M	6	J	12.2 (0.480)
221	39	K	6	N	16.5 (0.650)
222	39	M	6	N	16.5 (0.650)
479	39	K	6	J	16.5 (0.650)
480	39	M	6	J	16.5 (0.650)

High Voltage MLC Capacitors



Application Information on High Voltage MLC Capacitors

High value, low leakage and small size are difficult parameters to obtain in capacitors for high voltage systems. Olean Advanced Products' special high voltage MLC leaded capacitors meet these performance characteristics. The added advantage of these capacitors lies in special internal design minimizing the electric field stresses within the MLC. These special design criteria result in significant reduction of partial discharge activity within the dielectric and having, therefore, a major impact on long-term reliability of the product. The high voltage radial capacitors are conformally coated with high insulation resistance, high dielectric strength epoxy eliminating the possibility of arc flashover.

The high voltage radial MLC designs exhibit low ESRs at high frequency. The same criteria governing the high voltage design carries the added benefits of extremely low ESR in relatively low (0.05 μF to 0.005 μF) capacitance and small packages. These capacitors are designed and are ideally suited for applications such as snubbers in high frequency power converters, resonators in SMPS, and high voltage coupling/DC blocking.

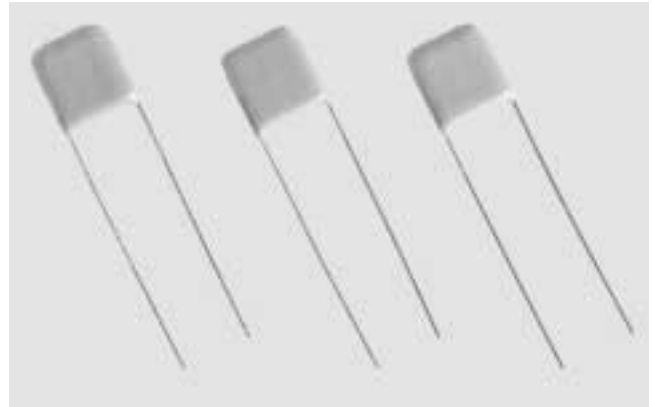

Also because these MLCs are designed for high voltage applications, as input resonator capacitors they are well safeguarded against transient requirements.

High voltage chips are available with voltage ratings greater or equal to 600 volts in EIA standard sizes 1808 and larger.

C0G DIELECTRIC GENERAL SPECIFICATIONS

Capacitance Range 100 pF to .15 μF (1.0 Vrms, 1 KHz)

Capacitance Tolerances $\pm 5\%$, $\pm 10\%$, $\pm 20\%$

Operating Temperature Range -55°C to $+125^{\circ}\text{C}$

Temperature Characteristic 0 ± 30 ppm/ $^{\circ}\text{C}$

Voltage Ratings 1000 Vdc thru 5000 Vdc ($+125^{\circ}\text{C}$)

Dissipation Factor 0.15% max. ($+25^{\circ}\text{C}$)
1.0 Vrms, 1 KHz

Insulation Resistance ($+25^{\circ}\text{C}$, at 500V)
100K $\text{M}\Omega$ min. or 1000 $\text{M}\Omega$ - μF min.,
whichever is less

Insulation Resistance ($+125^{\circ}\text{C}$, at 500V)
10K $\text{M}\Omega$ min., or 100 $\text{M}\Omega$ - μF min.,
whichever is less

Dielectric Strength 120% rated voltage, 5 seconds

Life Test 100% rated and $+125^{\circ}\text{C}$

X7R DIELECTRIC GENERAL SPECIFICATIONS

Capacitance Range 100 pF to 2.2 μF (1.0 Vrms, 1 KHz)

Capacitance Tolerances $\pm 10\%$, $\pm 20\%$, $+80\%$, -20%

Operating Temperature Range -55°C to $+125^{\circ}\text{C}$

Temperature Characteristic $\pm 15\%$ (0 Vdc)

Voltage Ratings 1000 Vdc thru 5000 Vdc ($+125^{\circ}\text{C}$)

Dissipation Factor 2.5% max. ($+25^{\circ}\text{C}$, 1.0 Vrms, 1 KHz)

Insulation Resistance ($+25^{\circ}\text{C}$, at 500V)
100K $\text{M}\Omega$ min., or 1000 $\text{M}\Omega$ - μF min.,
whichever is less

Insulation Resistance ($+125^{\circ}\text{C}$, at 500V)
10K $\text{M}\Omega$ min., or 100 $\text{M}\Omega$ - μF min.,
whichever is less

Dielectric Strength 120% rated voltage, 5 seconds

Life Test 100% rated and $+125^{\circ}\text{C}$

High Voltage MLC Capacitors



HIGH VOLTAGE RADIAL LEAD AVX STYLES: SV01 THRU SV12

HOW TO ORDER:

SV01

AVX Style

A

Voltage
1000V = A
2000V = G
3000V = H
4000V = J
5000V = K

A

Temperature Coefficient
C0G = A
X7R = C

102

Capacitance Code (2 significant digits + no. of zeros)

Examples:
10 pF = 100
100 pF = 101
1,000 pF = 102
22,000 pF = 223
220,000 pF = 224
1 μF = 105

K

Capacitance Tolerance

C0G: J = ±5%
K = ±10%
M = ±20%
X7R: K = ±10%
M = ±20%
Z = +80 -20%

A

A = Does not apply

A

A = Does not apply

Note: Capacitors with X7R and Z5U Dielectrics are not intended for AC line filtering applications. Contact Plant for recommendations.

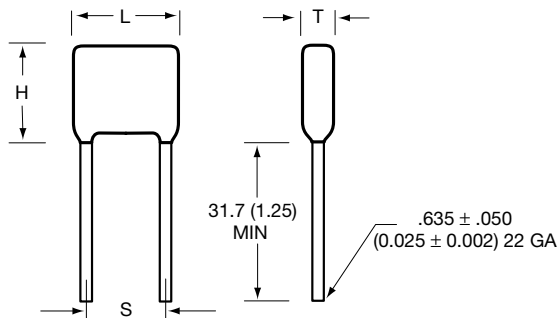

Note: Capacitors with X7R and Z5U Dielectrics are not intended for AC line filtering applications. Contact Plant for recommendations.

AVX Style	Length (L) max	Height (H) max	Thickness (T) max	Lead Spacing ±.030 (S)
SV01	.250 (0.100)	.220 (0.009)	.200 (0.008)	.170 (0.007)
SV02	.320 (0.013)	.280 (0.011)	.200 (0.008)	.220 (0.009)
SV03	.370 (0.015)	.300 (0.012)	.200 (0.008)	.275 (0.011)
SV04	.450 (0.018)	.220 (0.009)	.200 (0.008)	.300 (0.012)
SV05	.470 (0.019)	.400 (0.016)	.200 (0.008)	.375 (0.015)
SV06	.550 (0.021)	.280 (0.011)	.200 (0.008)	.400 (0.016)
SV07	.570 (0.022)	.500 (0.020)	.200 (0.008)	.475 (0.019)
SV08	.670 (0.026)	.600 (0.024)	.200 (0.008)	.575 (0.023)
SV09	.770 (0.030)	.720 (0.028)	.200 (0.008)	.675 (0.027)
SV10	1.050 (0.041)	.500 (0.020)	.200 (0.008)	.900 (0.035)
SV11	1.250 (0.050)	.600 (0.024)	.200 (0.008)	1.100 (0.043)
SV12	1.450 (0.057)	.720 (0.028)	.200 (0.008)	1.300 (0.051)

MAXIMUM CAPACITANCE VALUE

C0G					X7R						
Style	1000V	2000V	3000V	4000V	5000V	Style	1000V	2000V	3000V	4000V	5000V
SV01	1000pF	180pF	82pF	—	—	SV01	.012μF	1500pF	—	—	—
SV02	3300pF	680pF	270pF	150pF	100pF	SV02	.047μF	5600pF	2700pF	—	—
SV03	5600pF	1200pF	470pF	270pF	180pF	SV03	.082μF	.01μF	4700pF	1800pF	—
SV04	2200pF	470pF	180pF	100pF	68pF	SV04	.033μF	3900pF	1800pF	820pF	—
SV05	.015μF	3300pF	1200pF	680pF	470pF	SV05	.22μF	.027μF	.012μF	4700pF	—
SV06	.0068μF	1500pF	560pF	330pF	220pF	SV06	.10μF	.012μF	6800pF	2700pF	1200pF
SV07	.027μF	5600pF	2200pF	1200pF	820pF	SV07	.39μF	.047μF	.027μF	.01μF	6800pF
SV08	.039μF	.01μF	3900pF	2200pF	1500pF	SV08	.68μF	.082μF	.047μF	.018μF	.012μF
SV09	.068μF	.015μF	6800pF	3900pF	2700pF	SV09	1.00μF	.12μF	.068μF	.027μF	.018μF
SV10	.056μF	.012μF	5600pF	3300pF	2200pF	SV10	.82μF	.10μF	.056μF	.022μF	.018μF
SV11	.082μF	.022μF	.0082μF	4700pF	3300pF	SV11	1.2μF	.18μF	.10μF	.039μF	.027μF
SV12	.15μF	.033μF	.015μF	8200pF	5600pF	SV12	2.20μF	.27μF	.15μF	.056μF	.033μF

Note: Contact factory for other voltage ratings or values.

AVX IS QUALIFIED TO THE FOLLOWING DSCC DRAWINGS

Specification #	Description	Capacitance Range
87046	C0G-1000 VDC	10 pF - 0.025 μF
87043	X7R-1000 VDC	100 pF - 0.47 μF
87040	X7R-2000 VDC	100 pF - 0.22 μF
87114	C0G-3000 VDC	10 pF - 8200 pF
87047	X7R-3000 VDC	100 pF - 0.1 μF
87076	C0G-4000 VDC	10 pF - 6800 pF
89044	X7R-4000 VDC	100 pF - 0.056 μF
87077	C0G-5000 VDC	10 pF - 5600 pF
87070	X7R-5000 VDC	100 pF - 0.033 μF
87081	X7R-10000 VDC	470 pF - 0.01 μF

These specifications require group A and B testing per
C0G - MIL-PRF-20
X7R - MIL-PRF-39014



Single-In-Line Packages (SIP)



Capacitor Arrays

SIP-style, MLC ceramic capacitor arrays are Single-In-Line, conformally coated packages. These capacitor networks incorporate multiple capacitors into a single substrate and, therefore, offer excellent TC tracking. The utilization of

SIP capacitor arrays minimizes board real estate and reduces component count in the assembly. Various circuit configurations and capacitance/voltage values are available.

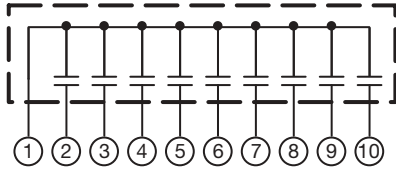

CIRCUIT CONFIGURATION "A"
ONE END LEAD GROUND

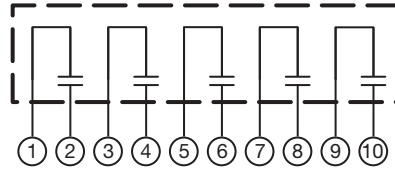

CIRCUIT CONFIGURATION "B"
ADJACENT LEAD PAIR CAPS

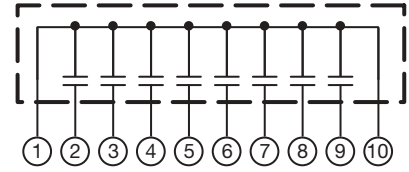

CIRCUIT CONFIGURATION "C"
BOTH END LEADS GROUND

Dimensions in millimeters (inches)

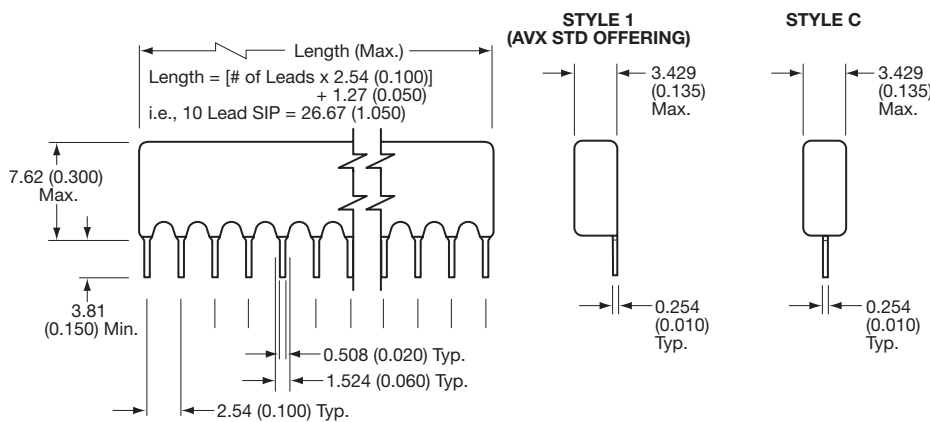

Maximum Capacitance*		
	50V	100V
COG	2200 pF	1500 pF
X7R	0.10 μ F	0.033 μ F
Z5U	0.39 μ F	0.10 μ F

HOW TO ORDER

SP	A	1	1	A	561	K	A	A
AVX Style	Circuit See Above (A, B, C)	Lead Style Offset = 1 Centered = C	Voltage 50V = 5 100V = 1	Temperature Coefficient COG = A X7R = C Z5U = E	Capacitance Code (2 significant digits + no. of zero) 10 pF = 100 100 pF = 101 1,000 pF = 102 22,000 pF = 223 220,000 pF = 224 1 μ F = 105 10 μ F = 106 100 μ F = 107	Capacitance Tolerance COG: K = \pm 10% M = \pm 20% X7R: K = \pm 10% M = \pm 20% Z = +80%, -20% Z5U: M = \pm 20% Z = +80%, -20% P = GMV (+100, -0%)	Test Level A = Standard	Number of Leads 2 = 2 3 = 3 4 = 4 5 = 5 6 = 6 7 = 7 8 = 8 9 = 9 A = 10 B = 11 C = 12 D = 13 E = 14

*For dimensions, voltages, or capacitance values not specified, please contact factory.

AVX IS QUALIFIED TO THE FOLLOWING DSCC DRAWINGS

SPECIFICATION #	DESCRIPTION	CIRCUIT	LEADS	CAPACITANCE RANGE
87112	BX-100 VDC	A	8	1000 pF - 0.1 μ F
87116	COG-100 VDC	A	8	10 pF - 820 pF
87119	BX-100 VDC	C	10	1000 pF - 0.1 μ F
87120	COG-100 VDC	C	10	10 pF - 1000 pF
87122	BX-100 VDC	B	8	1000 pF - 0.1 μ F
88019	BX-100 VDC	A	10	1000 pF - 0.1 μ F
89086	COG-100 VDC	B	8	10 pF - 820 pF



MIL-PRF-28861 QPL LIST

All are Class B available in Gold and Tin/Tin-Lead Plated Finish (Except /12)

MIL-PRF-28861/01

Style -001 thru -006, -009 thru -016
-019 thru -026, -031 thru -036

MIL-PRF-28861/04

Style -001 thru -036
(ALL)

MIL-PRF-28861/05

Style -001 thru -024
(ALL)

MIL-PRF-28861/12

Style -001 thru -036
(ALL)

Military Series DSCC DWG.#		
DSCC Specification #	Description	Capacitance Range
84083	Hermetic EMI Filter	JD Series
84084	Hermetic EMI Filter	JD Series
84080	Solder-in EMI Filter	WS Series
84081	Solder-in EMI Filter	XS Series
84082	Solder-in EMI Filter	YS Series
88010	Solder-in EMI Filter	ZS Series
86131	Bolt EMI Filter	SA Series
88051	Bolt EMI Filter	SA Series
55562	SMT Transient Suppressor	TransGuards

MIL-PRF-15733 QPL LIST

MIL-PRF-15733/23

Style -0001 thru -0006, -0013 thru -0018
-0025 thru -0030, -0037 thru -0042
-0049 thru -0054

MIL-PRF-15733/24

Style -0005 thru -0008

MIL-PRF-15733/26

Style -0001 thru -0007, -0009 thru -0011
-0013 thru -0019, -0021 thru -0023

MIL-PRF-15733/34

Style -0015
-0019
-0026

MIL-PRF-15733/38

Style -0002
-0004 thru -0006
-0008

MIL-PRF-15733/49

Style -0003, -0004, -0006, -0007

HIGH-REL EMI FILTERS

Noise is the enemy of good engineering design. Properly installed EMI filters suppress such electromagnetic interference on power and signal lines, while allowing desired signals to pass. For critical EMI filter applications, high reliability is of the utmost importance.

High reliability applications have diverse requirements, ranging from a need for a long operating life in medical or military systems to avoiding the prohibitive cost of replacing a faulty component in a satellite, undersea cable, or other inaccessible system. High-Rel filters satisfy application-critical requirements in many environments:

- Space/Satellite Systems
- Military Aircraft
- Guidance Systems
- Command, Control & Communications (C³)
- Missile Systems
- Weapon Systems
- Radar Systems
- Electro Optical Systems
- Electronic Countermeasures
- Electronic Warfare
- Pacemakers
- Medication Monitors

HIGH-REL STANDARDS

Reliability must be designed into an EMI filter. Every step in its manufacture from material selection through testing and characterization must be considered. To assure conformance to clearly define product and performance parameters, specifications have evolved for electrical performance,

mechanical configurations, test methods, screening and qualification procedures.

AVX Filters delivers high quality EMI filters which meet applicable portions of these high-reliability standards:

- MIL-F-15733
- MIL-F-28861
- MIL-I-45208A
- MIL-STD-202
- MIL-STD-220
- MIL-Q-9858
- NASA NHB 5300
- MIL-STD-790
- MIL-PRF-123
- ISO 9000
- MIL-STD-1547
- EIA-RS-469

AVX FILTERS AT THE LEADING EDGE

AVX Filters Corporation continues to provide innovative solutions to the high performance needs of its customers. It has pioneered many breakthroughs which have advanced the state-of-the-art in this demanding discipline, including:

- The first to qualify to the new High-Reliability Filter Spec, MIL-F-28861.
- Facility qualified to MIL-STD-790 during first round of audits for filter manufacturers.
- The first solder-in filter line to offer 400°C installation temperature.
- The first filter line designed to meet the new MIL-Spec requirements for heat rise/reactive current in 125 VAC and 230 VAC 400 Hz applications.
- The first to offer a filter line of hermetically sealed bolt style filters.
- The first manufacturer of medical implantable filters.

CUSTOM AND SEMI-CUSTOM

In addition to standard catalog and QPL EMI filters, AVX Filters produces two classes of these special products: Semi-custom and Custom. Semi-custom involves variations in electrical parameters, testing, and limited mechanical changes from standard product designs. Delivery is slightly longer and price is slightly higher than standard products.

Custom products require longer lead time for design and manufacturing, but give designers freedom to specify non-standard mechanical and electrical filter designs.

AVX filters dedicates a unique internal part number to every semi-custom and custom component. This insures continued configuration control for each part, allows future changes to be easily implemented, and provides assurance that the design always matches the customer requirements.

ENGINEER TO ENGINEER

Our application engineering staff will assist in defining your filter requirements, while recommending advantages, reliability, quality assurance levels, and filter performance at the lowest practical cost. They will help in filter selection and specification, including meeting DESC requirements. SCD models are available to assist you in the design process. A custom filter part number will be assigned exclusively to your SCD. To obtain prompt professional assistance, call **(818) 767-6770**.

QUALITY ASSURANCE

Quality assurance is built into every stage of manufacturing and testing. AVX Filters controls the entire process, from the capacitor's dielectric formulation through final filter test. This results in absolute traceability by lot number to a specific dielectric batch, as well as the subsequent materials, equipment and employees involved in the tightly-controlled manufacturing and testing process. In addition, critical processes are monitored using SQC, SPC techniques.

HIGH-RELIABILITY FILTER DESIGN GUIDE

To produce a high-rel filter, the manufacturing processes, the procedures, and the materials used must be kept under tight control. By monitoring and tagging these on a lot and order basis, any product failures or performance abnormalities can be traced. At AVX Filters, such information is kept on file for later traceability and analysis.

Baseline – A baseline is a system of documentation that is used to guarantee manufacturing consistency, control change, and establish reporting structure. It sets up the mechanisms to define manufacturing, materials and components selection and qualification, as well as inspections and tests. It can also define mechanisms for direct comparisons to test the difference between lots and orders.

An example of a baseline is the MIL-PRF-28861 baseline that is defined for the space level components. With this baseline in place, all the mechanisms are defined to support Class S filter production and quality assurance. AVX Filters is qualified as a Class S facility. Changes to the baseline are monitored and approved by DESC, NASA and Aerospace Corporation. Custom baselines can also be developed to fulfill specific customer requirements.

MIL-STD-790 – This standard sets up a full reliability assurance program plan with full traceability to raw materials, manufacturing processes, assembly, and tests. At AVX Filters there is full traceability down to the raw materials such as plating elements, base metals, ceramic materials, and inks, in accordance with MIL-STD-790. Other programs in this standard include failure analysis, documentation control and operator training requirements. MIL-PRF-28861 relies on this standard to define the reliability assurance program for the Class S filters.

QPL – EMI filters which fully meet MIL standards are placed on a Qualified Products List (QPL) by a specifying agency such as DESC. The MIL-qualified filters can then be ordered directly by QPL part number. This is indicated by the MIL-PRF-28861 and MIL-PRF-15733 QPL sections of the catalog.

Reliability Quality Assurance

A key factor in insuring quality components, and high reliability performance, is the implementation of appropriate tests and inspections during the manufacturing process.

There are a number of defined standards that specify the design parameters, tests and test setups, materials used, and the quality assurance provisions required. Vendor parts that are qualified to the standards are put on QPL lists for that standard.

Design and component engineers can order these standard QPL filters with their attendant specifications. Other parameters can be added to meet specific needs or define a full quality assurance program.

MIL-PRF-15733 – This is an older standard developed for specifying EMI/RFI filters. It defines specific electrical and mechanical requirements, as well as stress tests and inspections. MIL-PRF-15733 does not require full 100% testing of each component, but relies upon sample testing for each lot.

It also defines quality assurance inspections, and specifies a quality assurance reporting mechanism with yearly reports required on overall quality assurance performance. It makes use of standards such as MIL-STD-202 to define test methods.

MIL-PRF-28861 – This is a modern standard, defining stringent classes of quality. The higher level, Class S, is for critical space type applications where failure may have catastrophic results. Detailed Group A screening and Group B environmental and qualification tests are fully described.

MIL-PRF-28861 is approved for use by all departments and agencies of the Department of Defense. Like the earlier 15733, it defines filters for EMI applications. However, it goes into detailed requirements for a number of attributes such as baseline control, capacitor dielectrics, filter inductors, case and lead finishes, potting/impregnants, X-ray, DPA, SLAM and soldering methods.

Quality conformance inspection (QCI), or “Group A” testing, is performed on 100% of the filters for each production lot with limits on the number of failures allowed. For Class S filters, baseline documentation is required to track the major process steps and inspection points in manufacturing and quality assurance. This baseline also “locks” in the design through configuration control. Changes to the product design, or the process steps for defined areas, can only be done with formal government approval. Class “S” devices are qualified on a lot-by-lot basis, with Group A and B screening and testing documented on each manufacturing lot.

All AVX Filters internal design standards reflect these three standards of performance and reliability. For detailed information on these standards, see Filter Design Guide, M28861 Screening and R-Level Screening sections of catalog.

Group A, B Tests – These tests or inspections are typically defined by MIL-PRF-15733. The Group A screening test sequence will include thermal shock, voltage conditioning,

and the measurement of basic electrical parameters for the filter. It also defines visual and radiographic inspections. All filters in a lot are 100% tested, when Group A per MIL-PRF-28861 is performed. Sample inspection of a filter lot is performed when Group A per MIL-PRF-15733 is specified.

Group A per MIL-PRF-28861 stipulates that up to 10% of tested Class B filters can be defective, and are simply removed from the lot. Failure rates in excess of 10% will cause the entire lot to be rejected.

Class S filters are only allowed PDA rates ranging from 2 to 3% on individual tests. If the combined total failures exceed 10%, then the lot must be scrapped.

Group B screening defines environmental tests on samples from the production lots. Some of these tests are destructive, including Destructive Physical Analysis (DPA). These tests permit a percentage of failure for each sampling of Class B Filters. No failures are permitted for Class S filters.

DPA – Destructive Physical Analysis to RS-469 is a quality assurance technique that involves taking lot samples and cross-sectioning them for internal inspection. A filter is sectioned and then polished for microscopic examination. This is used to detect specific filter defects, such as flawed interconnects, capacitor voids, improper margins, dielectric separation (delamination), and improper dielectric grain growth. For detailed information see DPA Criteria section.

Military EMI/RFI Filters



Filter Design Guide

High Reliability/Military Qualified Products

MIL-PRF-28861 SCREENING

Class S, Class B

The Group A sequence as outlined in MIL-PRF-28861 is performed on a 100% basis whenever reliability codes for

Class S or Class B are specified by the customer. Differences between Class S and Class B screening are shown in the descriptions.

S-CLASS, B-CLASS TESTING

Test	MIL-STD-202 (method)	Description
Thermal Shock	107, cond. A	S-class: 5 cycles from -55°C to +125°C. Through hole mounting required. B-class: as above except mounting not required.
Burn-in	108	S-class: 168 hours minimum at 2.0X rated voltage, 125°C polarity reversal for the first 24-72 hours; fused B/I circuit for each filter. B-class 164 ± 4 hours at 2.0X rated voltage.
Dielectric Withstanding Voltage	301	S-class, B-class: 2.5X rated DC voltage for 5 seconds minimum, 1 minute maximum, 50 mA charging current.
Insulation Resistance	302, cond. A	S-class: test at 100 VDC or rated, V, whichever is less. Pass/fail limits are lot also based upon 125°C readings from first 50 pieces.
Capacitance and Dissipation Factor	305	B-class: same as above, except omit pass/fail as per 50 piece calculation. S-class, B-class: test at 1000 ± 100 Hz, 0.1 to 1.2 VRMS.
Insertion Loss	—	S-class, B-class: per MIL-STD-220 at load, no-load as specified.
DC Resistance	303	S-class, B-class: test is optional if DC Voltage Drop Test performed.
Voltage Drop	—	S-class, B-class: M28861 para 4.6.6.1 (AC rated), para 4.6.6.2 (DC rated)
Radiographic Inspection	209	S-class, B-class: 2 views required with 10X examination of images.
Seal Test	112	S-class: condition C B-class: condition A or D
Visual and Mechanical	—	S-class: M28861 para. 4.6.1.2 which includes element, subassembly, and pre-cap inspections. B-class: M28861 para. 4.6.1.1 for external visual only.
Solderability	208	S-class, B-class: 5 samples.

MILITARY QUALIFIED PRODUCTS

There have been many questions raised regarding the differences between MIL-PRF-15733 and MIL-PRF-28861. To

clarify these differences we have incorporated the following Analysis Chart which compares the differences between these two military specifications.

ANALYSIS MIL-PRF-15733 vs. MIL-PRF-28861

MIL-PRF-15733 Characteristics	MIL-PRF-28861 Filter/Design/Construction	Filter/Design/Construction	
		Class B	Class S
Case	Standard	Standard	Standard
Capacitor (Discoidal) • Dielectrics • K • VTL • Cap Range	Standard X7R, Z5U 2200-10K N/A Max Cap/Case Size	Special Design BR 2K max +15%, -40% Limited Cap/Case Size Conversion Design	Special Design BX 2K max +15%, -25% (when design permits) Limited Cap/Case Size & MIL-PRF-123 Req'ts Conversion Design
	Testing	Testing	
Group A • Test • PDA (parts defective allowed)	MIL-STD-105, 1.0% AQL None	100% Test 10%	100% Test Thermal Shock, Burn-in*, IR & DWV-2% each test Cap, Volt. Drop, Insertion Loss -3% max combined Total 10% max
X-Ray	None	MIL-STD-202 Method 209	MIL-STD-202 Method 209
Leak Test	Condition "A" Gross Leak	Condition "A" Gross Leak PDA 10% max	Condition "A" Gross Leak Condition "C" Fine Leak PDA 10% max
Burn-In	None generally. A few slash sheets require 1.4 x rated voltage	160 Hrs. @ 2 x rated voltage – Resistor protected	168 Hrs. (250 Hrs. max) @ 2 x rated voltage – Fuse protected *PDA .2% max last 50 hrs.
Insertion Loss	1.0% AQL	100%	100%
Solderability	None	MIL-STD-202 Method 208 5 Samples	MIL-STD-202 Method 208 5 Samples



Military EMI/RFI Filters



MIL-PRF-28861/01, /04, /05, /12

HOW TO ORDER

MIL-PRF-28861

Mil-Spec Number

/02

Slash Sheet

- 001

Dash Number

G

Finish*
G = Gold
T = Tin/Tin Lead

B

Class

MIL-PRF-28861/01

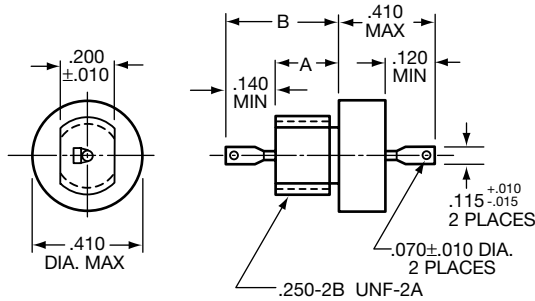

Dash number	Circuit	Rated voltage		Min. capacitance (µF)
		DC volts	AC 1/ volts	
001, 011	L2	50	---	1.2
002, 012	C	50	---	1.2
003, 013	L2	70	---	0.7
004, 014	C	70	---	0.7
005, 015	L2	100	---	0.45
006, 016	C	100	---	0.45
009, 019	L2	200	125	0.15

Dash number	Circuit	Rated voltage		Min. capacitance (µF)
		DC volts	AC 1/ volts	
010, 020	C	200	125	0.15
021, 031	L2	200	125	0.01
022, 032	C	200	125	0.01
023, 033	L2	200	125	0.0027
024, 034	C	200	125	0.0027
025, 035	L2	200	125	0.001
026, 036	C	200	125	0.001

MIL-PRF-28861/04

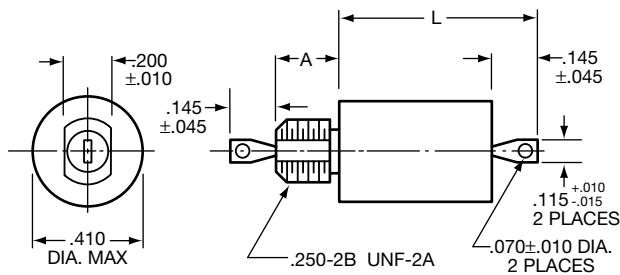

Dash number	Circuit	Max. current (amps)	Min. capacitance (µF)	Max. voltage drop (volts)	Max. DC resistance (ohms)
002, 020	L2	0.10	0.70	0.17	1.7
003, 021	π	0.10	1.4	0.17	1.7
004, 022	L1	0.30	0.70	0.23	0.77
005, 023	L2	0.30	0.70	0.23	0.77
006, 024	π	0.30	1.4	0.23	0.77
007, 025	L1	0.50	0.70	0.18	0.36
008, 026	L2	0.50	0.70	0.18	0.36
009, 027	π	0.50	1.4	0.18	0.36

Dash number	Circuit	Max. current (amps)	Min. capacitance (µF)	Max. voltage drop (volts)	Max. DC resistance (ohms)
011, 029	L2	1.0	0.70	0.14	0.14
012, 030	π	1.0	1.4	0.14	0.14
013, 031	L1	3.0	0.70	0.15	0.05
014, 032	L2	3.0	0.70	0.15	0.05
015, 033	π	3.0	1.4	0.15	0.05
016, 034	L1	5.0	0.70	0.075	0.015
017, 035	L2	5.0	0.70	0.075	0.015
018, 036	π	5.0	1.4	0.075	0.015

Military EMI/RFI Filters



MIL-PRF-28861/01, /04, /05, /12

MIL-PRF-28861/05

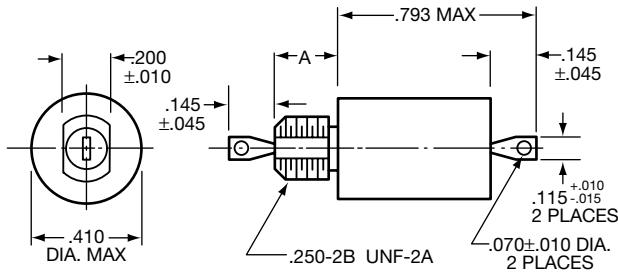

Dash number	Circuit	Max. current (amps)	Capacitance (µF) +100% -0%	Max. voltage drop (volts)	Max. DC resistance (ohms)
001, 013	L1	0.25	0.15	0.375	1.5
002, 014	L2	0.25	0.15	0.375	1.5
003, 015	π	0.25	0.30	0.375	1.5
004, 016	L1	1.0	0.15	0.250	0.25
005, 017	L2	1.0	0.15	0.250	0.25
006, 018	π	1.0	0.30	0.250	0.25

Dash number	Circuit	Max. current (amps)	Capacitance (µF) +100% -0%	Max. voltage drop (volts)	Max. DC resistance (ohms)
007, 019	L1	3.0	0.15	0.150	0.05
008, 020	L2	3.0	0.15	0.150	0.05
009, 021	π	3.0	0.30	0.150	0.05
010, 022	L1	5.0	0.15	0.075	0.015
011, 023	L2	5.0	0.15	0.075	0.015
012, 024	π	5.0	0.30	0.075	0.015

MIL-PRF-28861/12

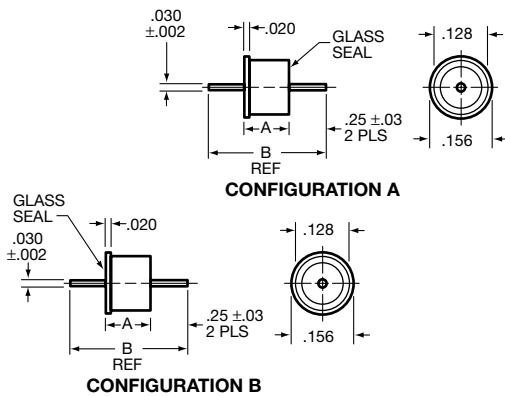

Dash number	Circuit	Rated voltage DC	Minimum capacitance (µF)
001, 017	L	50	15000
003, 019	L	100	2700
005, 021	L	100	5000
007, 023	L	200	10
009, 025	L	200	25
011, 027	L	200	100
013, 029	L	200	500
015, 031	L	200	1000
033, 035	L	50	10000

Dash number	Circuit	Rated voltage DC	Minimum capacitance (µF)
002, 018	C	50	15000
004, 020	C	100	2700
006, 022	C	100	5000
008, 024	C	200	10
010, 026	C	200	25
012, 028	C	200	100
014, 030	C	200	500
016, 032	C	200	1000
034, 036	C	50	10000

* Only available in gold finish

(See MIL-PRF-22861 for insertion loss and other specification details.)



TPC Power Capacitors for Military Applications



TPC, previously Thomson Passive Components, now a division of AVX Corporation has been a supplier of power capacitors for specialized applications, both military and commercial, for more than 30 years. We have custom capabilities and make capacitors to meet a wide range of high voltage and high power applications.

TPC Power Products (for discharge / pulse and pulse forming network applications):

Energy Densities	500J / liter to 1100J / liter
Peak Current Capabilities	up to 250kA
Voltages	up to 100kV
Inductances	as low as 8nH

Discharge (Pulse Power) Applications:

- Marx Generators
- Explosion Test Equipment
- Particle Beam Generators (Weapons Systems)
- Fusion Laser Applications
- EMC Test Sets
- Laser Weapons



Filtering Applications:

- High power DC / AC inverters
- High power DC / DC conversion

Our staff are well prepared to design and manufacture capacitors for your specific applications. Please contact us with your needs.

Pulse Forming Network Applications Include:

- Radars
- Electromagnetic Launchers
- Klystron Tube Test Equipment
- High Power Microwave Systems (Weapons Systems)



TPC High Power Capacitors Technology for Discharge Applications



For the High Power Capacitor market and specifically for discharge applications, TPC can offer two complementary technologies:

1) CONTROLLED SELF-HEALING TECHNOLOGY for medium and high specific density of energy.

2) FILM FOIL TECHNOLOGY for very high peak current and very low inductance.

1) CONTROLLED SELF-HEALING TECHNOLOGY was developed by TPC in order to guarantee a total safety of working. The end of lifetime is guaranteed “soft” ie., no short-circuit, no catastrophic failure, with the failure mode being only some few % losses of capacitance.

CONTROLLED SELF-HEALING TECHNOLOGY uses a metallized polypropylene film, with segmentation or specific metallization, the “soft” concept being to divide the total capacitance in elementary capacitor cells. In the case of ageing weak points within the film, the energy in the capacitor will discharge in the low impedance (weak points), but the segmentation and/or specific metallization will induce a serial non linear impedance to reduce the self-healing energy first and to limit the maximum of self-healing energy with 100% margin below the limit of destruction. Therefore the weak points are insulated from the rest of capacitor without any mechanical, thermal or electrical consequence except some few % losses of capacitance. The criteria of end of lifetime can be -2% or -5% of capacitance lost. An added advantage is that during operation, maintenance is easy to control by monitoring the capacitance change over time.

CONTROLLED SELF-HEALING combined with rape seed (canola) oil impregnation is the solution for:

- **DC FILTERING** in the voltage range 1200V up to 80kV with density of energy:
340J/l (U_n @ 70°C_{hot spot} @ 100,000h)
- **ENERGY DISCHARGE** in the voltage range 1200V up to 80kV with density of energy:
2000J/l (1,000 shots @ 10% reverse @ ambient temperature)

2) FILM FOIL TECHNOLOGY is used where there is a requirement for high and short power pulses (more than 1000A_s/μF).

To meet low inductance and no catastrophic behavior in case of short-circuit, TPC can propose a solution with single track elementary bobin to withstand electrical field associated with strip line design to withstand current pulses. As a result any gas production is limited and explosion will not occur.

Several integrated shapes can be designed to meet classical or “exotic” discharge applications for:

- Marx generator
- MWW
- Pulse Forming Network

In a voltage range up to 100kV

To meet low inductance down to 8nH

With high peak current up to 500kA

Power military applications are very specific, but TPC is organized to develop specific products to meet customer specification.

In the case where no specification is available please contact your local AVX Sales Office.

SMPS Capacitors Chip Assemblies

CH/CV - Radial, Dual-in-Line, 4 Terminal/SMT 'J' & 'L' Ranges



European Preferred Styles

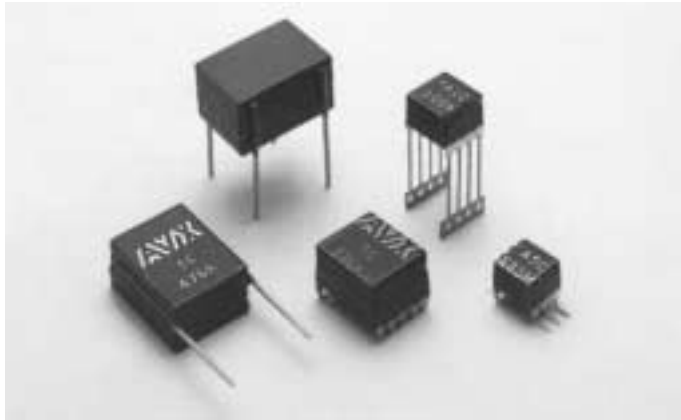

10nF to 180 μ F BS9100 approved
 50V to 500 VDC Low ESR/ESL
 -55°C to +125°C 1B/C0G and 2C1/X7R Dielectrics

This range allows SMPS engineers to select the best volumetric solution for input and output filter applications in high reliability designs. Utilizing advanced multilayer ceramic techniques to minimize ESR/ESL giving high current handling properties appropriate for filtering, smoothing and decoupling circuits.

ELECTRICAL SPECIFICATIONS

Temperature Coefficient CECC 30 000, (4.24.1)

1B/C0G: A Temperature Coefficient - 0 ± 30 ppm/°C, -55° to +125°C

2C1/X7R: C Temperature Characteristic - $\pm 15\%$, -55° to +125°C

Capacitance Test 25°C

1B/C0G: Measured at 1 VRMS max at 1KHz (1MHz for 100 pF or less)

2C1/X7R: Measured at 1 VRMS max at 1KHz

Dissipation Factor 25°C

1B/C0G: 0.15% max at 1KHz, 1 VRMS max (1MHz for 100 pF or less)

2C1/X7R: 2.5% max at 1KHz, 1 VRMS max

Insulation Resistance 25°C

1B/C0G & 2C1/X7R: 100K megohms or 1000 megohms- μ F, whichever is less

Dielectric Withstanding Voltage 25°C (Flash Test)

1B/C0G & 2C1/X7R: 250% rated voltage for 5 seconds with 50 mA max charging current. (500 Volt units @ 150% rated voltage)

Life Test (1000 hrs) CECC 30 000 (4.23)

1B/C0G & 2C1/X7R: 200% rated voltage at +125°C.
(500 Volt units @ 120% rated voltage)

Damp Heat IEC 68-2-3, 56 days.

Thermal Shock IEC 68-2-14

-55°C to +125°C, 5 cycles

Resistance to Solder Heat IEC 68-2-20

Vibration IEC 68-2-6

10Hz - 2000Hz, 0.75mm or 98m/sec², 6 hrs.

Bump IEC 68-2-29

390m/sec², 4000 bumps

MARKING

CH and CV 4x, 5x, 81-84

A5C	Top line A (AVX). Voltage code, dielectric code.
225K	Middle line capacitance code, tolerance code.
xxxxxx	Bottom line 6 digit batch code.

Other CH, CV Styles

AVX	Top line AVX.
5C	Second line voltage code, dielectric code.
156M	Third line capacitance code, tolerance code.
xxxxxx	Bottom line, 6 digit batch code.

SMPS Capacitors (CV Style)

Chip Assemblies



European Preferred Styles

VERTICALLY MOUNTED RADIAL PRODUCT

Part Number format (CVxxxxxxxxxxS2)

Typical Part Number CV525C106MA33S2

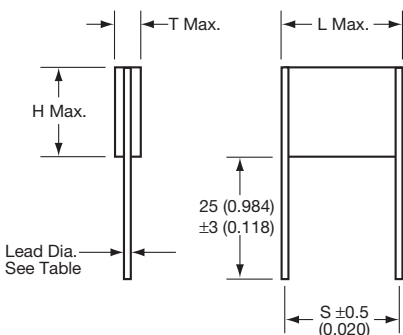

DIMENSIONS

millimeters (inches)

Style	L (max)	H (max)	S (nom)	Lead Dia (nom)
CV41-44	10.6 (0.417)	8.7 (0.342)	8.2 (0.322)	0.7 (0.028)
CV51-54	11.9 (0.468)	10.7 (0.421)	10.2 (0.400)	0.9 (0.035)
CV61-64	16.5 (0.649)	13.6 (0.535)	15.2 (0.600)	0.9 (0.035)
CV71-74	17.8 (0.700)	21.6 (0.850)	15.2 (0.600)	0.9 (0.035)
CV76-79	22.7 (0.893)	16.6 (0.653)	21.2* (0.834)	0.9 (0.035)

*Tolerance ± 0.8 (0.031)

millimeters (inches)

Style	T max
CV41/51/61/71/76	3.80 (0.150)
CV42/52/62/72/77	7.40 (0.291)
CV43/53/63/73/78	11.1 (0.437)
CV44/54/64/74/79	14.8 (0.583)

VERTICALLY MOUNTED 4 TERMINAL RADIAL PRODUCT

Part Number format (CVxxxxxxxx8xx4)

Typical Part Number CV435C106MA34B4

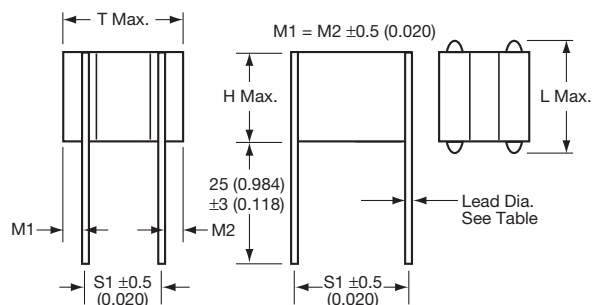

DIMENSIONS

millimeters (inches)

Style	L (max)	H (max)	S (nom)	Lead Dia (nom)
CV43-44	10.6 (0.417)	8.7 (0.342)	8.2 (0.322)	0.7 (0.028)
CV53-54	11.9 (0.468)	10.7 (0.421)	10.2 (0.400)	0.9 (0.035)
CV63-64	16.5 (0.649)	13.6 (0.535)	15.2 (0.600)	0.9 (0.035)
CV73-74	17.8 (0.700)	21.6 (0.850)	15.2 (0.600)	0.9 (0.035)
CV78-79	22.7 (0.893)	16.6 (0.653)	21.2* (0.834)	0.9 (0.035)

*Tolerance ± 0.8 (0.031)

millimeters (inches)

Style	T max	S1
CV43/53/63/73/78	11.1 (0.437)	5.08 (0.200)
CV44/54/64/74/79	14.8 (0.583)	7.62 (0.300)

Note 1. This style is only available in 3 & 4 chip assemblies

HOW TO ORDER

CV	52	5	C	106	M	A	3	0	A	2
Style Code (see product section)	Size Code	Voltage Code 5 = 50V 1 = 100V 2 = 200V 7 = 500V	Dielectric Code A = COG C = X7R	Capacitance Code (2 significant digits + no. of zeros) eg. 105 = 1 µF 106 = 10 µF 107 = 100 µF	Capacitance Tolerance J = ±5% K = ±10% M = ±20% P = -0 +100%	Specification Code A = Non-customized See page 121 for how to order BS9100 parts	Finish Code 3 = Uncoated 8 = Coated (Classified as uninsulated)	Lead Dia. Code Standard	Lead Space Code Standard	Lead Style Code 2 = 2 Terminal 4 = 4 Terminal See Note 1 above

SMPS Capacitors (CH Style)

Chip Assemblies



European Preferred Styles

HORIZONTALLY MOUNTED 4 TERMINAL RADIAL PRODUCT

Part Number format (CHxxxxxxxx8xx4)

Typical Part Number CH782C106MA83D4

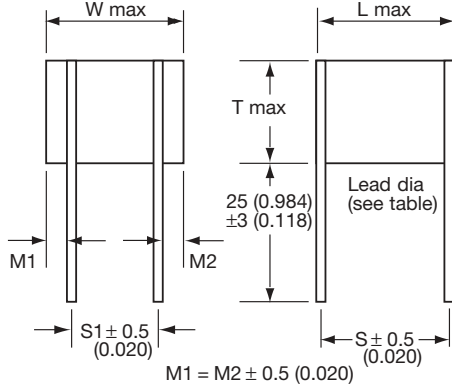

DIMENSIONS

millimeters (inches)

Style	L (max)	W (max)	S (nom)	S Lead Dia (nom)	S1 (nom)
CH42-44	10.6 (0.417)	8.7 (0.342)	8.2 (0.322)	0.7 (0.028)	5.08 (0.200)
CH52-54	11.9 (0.468)	10.7 (0.421)	10.2 (0.400)	0.9 (0.035)	7.62 (0.300)
CH62-64	16.5 (0.649)	13.6 (0.535)	15.2 (0.600)	0.9 (0.035)	7.62 (0.300)
CH72-74	17.8 (0.700)	21.6 (0.850)	15.2 (0.600)	0.9 (0.035)	15.2 (0.600)
CH77-79	22.7 (0.893)	16.6 (0.653)	21.2* (0.834)	0.9 (0.035)	10.2 (0.400)
CH82-84	14.1 (0.555)	38.2 (1.503)	10.2 (0.400)	0.9 (0.035)	27.9 (1.100)
CH87-89	17.8 (0.700)	38.2 (1.503)	15.2 (0.600)	1.0 (0.039)	27.9 (1.100)
CH92-94	22.7 (0.893)	40.6 (1.598)	21.2* (0.834)	1.2 (0.047)	30.5 (1.200)

*Tolerance ± 0.8 (0.031)

NOTE: This style is only available in 2, 3 & 4 chip assemblies only

millimeters (inches)

Style	T max
CH42/52/62/72/77/87/92	7.4 (0.291)
CH43/53/63/73/78/88/93	11.1 (0.437)
CH44/54/64/74/79/89/94	14.8 (0.583)

HORIZONTALLY MOUNTED DUAL-IN-LINE PRODUCT

Part Number format (CHxxxxxxxx0A0)

Typical Part Number CH615C106MA40A0

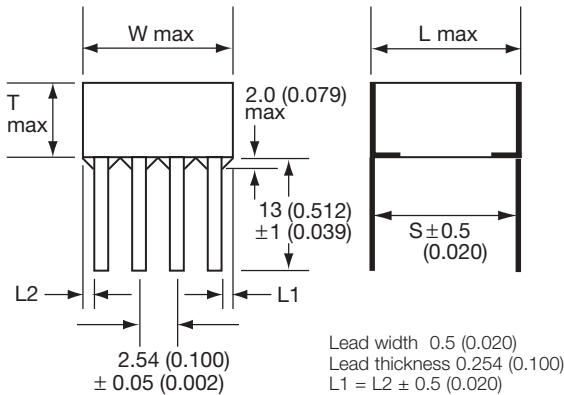

DIMENSIONS

millimeters (inches)

Style	L (max)	W (max)	S (nom)	No. of Leads per side
CH41-44	9.2 (0.362)	8.7 (0.342)	8.2 (0.322)	3
CH51-54	10.7 (0.421)	10.7 (0.421)	10.2 (0.400)	4
CH61-64	14.9 (0.586)	13.6 (0.535)	14.0 (0.551)	5
CH71-74	16.8 (0.661)	21.6 (0.850)	15.2 (0.600)	7
CH76-79	21.6 (0.850)	16.6 (0.653)	20.3* (0.800)	6
CH81-84	12.0 (0.472)	38.2 (1.503)	10.2 (0.400)	14
CH86-89	18.9 (0.744)	38.2 (1.503)	15.2 (0.600)	14
CH91-94	24.0 (0.944)	40.6 (1.598)	20.3* (0.800)	14

*Tolerance ± 0.8 (0.031)

millimeters (inches)

Style	T max
CH41/51/61/71/76/81/86/91	3.8 (0.150)
CH42/52/62/72/77/82/87/92	7.4 (0.291)
CH43/53/63/73/78/83/88/93	11.1 (0.437)
CH44/54/64/74/79/84/89/94	14.8 (0.583)

HOW TO ORDER

CH	52	5	C	106	M	A	3	0	A	0
Style Code (see product section)	Size Code	Voltage Code	Dielectric Code	Capacitance Code (2 significant digits + no. of zeros) eg. 105 = 1 µF 106 = 10 µF 107 = 100 µF	Capacitance Tolerance	Specification Code	Finish Code	Lead Dia. Code	Lead Space Code	Lead Style Code
	5 = 50V 1 = 100V 2 = 200V 7 = 500V	A = COG C = X7R	J = ±5% K = ±10% M = ±20% P = -0 +100%	A = Non-customized See page 121 for how to order BS9100 parts	3 = Uncoated 8 = Coated (Classified as uninsulated)	Standard	Standard	0 = Straight dual in line 4 = 4 Terminal		



SMPS Capacitors (CH Style)



European Preferred Styles

Chip Assemblies

HORIZONTALLY MOUNTED 'L' LEAD SMT PRODUCT

Part Number format (CHxxxxxxxxxx0A7)

Typical Part Number CH411C275KA40A7

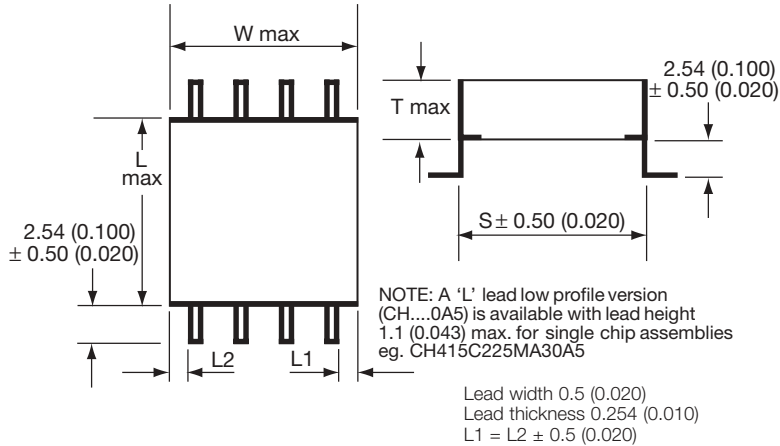

DIMENSIONS

millimeters (inches)

Style	L (max)	W (max)	S (nom)	No. of Leads per side
CH41-44	9.2 (0.362)	8.7 (0.342)	8.2 (0.322)	3
CH51-54	10.7 (0.421)	10.7 (0.421)	10.2 (0.400)	4
CH61-64	14.9 (0.586)	13.6 (0.535)	14.0 (0.551)	5
CH71-74	16.8 (0.661)	21.6 (0.850)	15.2 (0.600)	7
CH76-79	21.6 (0.850)	16.6 (0.653)	20.3* (0.800)	6
CH81-84	12.0 (0.472)	38.2 (1.503)	10.2 (0.400)	14
CH86-89	18.9 (0.744)	38.2 (1.503)	15.2 (0.600)	14
CH91-94	24.0 (0.944)	40.6 (1.598)	20.3* (0.800)	14

*Tolerance ± 0.8 (0.031)

millimeters (inches)

Style	T max
CH41/51/61/71/76/81/86/91	3.8 (0.150)
CH42/52/62/72/77/82/87/92	7.4 (0.291)
CH43/53/63/73/78/83/88/93	11.1 (0.437)
CH44/54/64/74/79/84/89/94	14.8 (0.583)

HORIZONTALLY MOUNTED 'J' LEAD SMT PRODUCT

Part Number format (CHxxxxxxxxxx0A8)

Typical Part Number CH411C275KA40A8

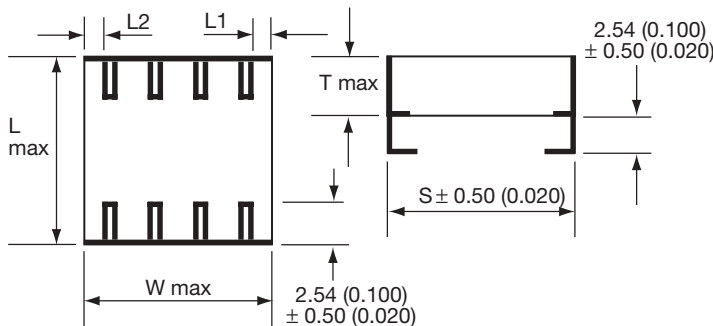

NOTE: A 'J' lead low profile version (CH...0A3) is available with lead height 1.1 (0.043) max. for single chip assemblies eg. CH515C475MA30A3

Lead width 0.5 (0.020)
Lead thickness 0.254 (0.010)
L1 = L2 ± 0.5 (0.020)

DIMENSIONS

millimeters (inches)

Style	L (max)	W (max)	S (nom)	No. of Leads per side
CH41-44	9.2 (0.362)	8.7 (0.342)	8.2 (0.322)	3
CH51-54	10.7 (0.421)	10.7 (0.421)	10.2 (0.400)	4
CH61-64	14.9 (0.586)	13.6 (0.535)	14.0 (0.551)	5
CH71-74	16.8 (0.661)	21.6 (0.850)	15.2 (0.600)	7
CH76-79	21.6 (0.850)	16.6 (0.653)	20.3* (0.800)	6
CH81-84	12.0 (0.472)	38.2 (1.503)	10.2 (0.400)	14
CH86-89	18.9 (0.744)	38.2 (1.503)	15.2 (0.600)	14
CH91-94	24.0 (0.944)	40.6 (1.598)	20.3* (0.800)	14

*Tolerance ± 0.8 (0.031)

millimeters (inches)

Style	T max
CH41/51/61/71/76/81/86/91	3.8 (0.150)
CH42/52/62/72/77/82/87/92	7.4 (0.291)
CH43/53/63/73/78/83/88/93	11.1 (0.437)
CH44/54/64/74/79/84/89/94	14.8 (0.583)

HOW TO ORDER

CH	52	5	C	106	M	A	3	0	A	7
Style Code (see product section)	Size Code	Voltage Code	Dielectric Code	Capacitance Code	Capacitance Tolerance	Specification Code	Finish Code	Lead Dia. Code	Lead Space Code	Lead Style Code
		5 = 50V 1 = 100V 2 = 200V 7 = 500V	A = COG C = X7R	(2 significant digits + no. of zeros) eg. 105 = 1 µF 106 = 10 µF 107 = 100 µF	J = ±5% K = ±10% M = ±20% P = -0 +100%	A = Non-customized See page 121 for how to order BS9100 parts	3 = Uncoated 8 = Coated (Classified as uninsulated)	Standard	Standard	3 = Low profile 'J' (single chip) 5 = Low profile 'L' (single chip) 8 = 'J' Dual in line



SMPS Capacitors (CH/CV Style)

Chip Assemblies



European Preferred Styles

C0G DIELECTRIC ULTRA STABLE CERAMIC

Cap µF	CH/CV41-44 Styles				CH/CV51-54 Styles				CH/CV61-64 Styles				CH/CV71-74 Styles				CH/CV76-79 Styles				CH81-84 Styles				CH86-89 Styles				CH91-94 Styles															
	50	100	200	500	50	100	200	500	50	100	200	500	50	100	200	500	50	100	200	500	50	100	200	500	50	100	200	500	50	100	200	500	50	100	200	500								
Voltage DC																																												
0.01				41																																								
0.012				41																																								
0.015				41																																								
0.018				41																																								
0.022				42				51																																				
0.027				42				51																																				
0.033			41	42				52			61																																	
0.039			41	42				52			61																																	
0.047		41	41	43				52			61																																	
0.056		41	41	43				52			61																																	
0.068	41	41	41	44			51	53			62			71			76			81																								
0.082	41	41	42				51	53			62			71			76			81																								
0.1	41	42	42			51	51	54			62			71			76			81																								
0.12	42	42	42		51	51	52			61	62			72			77			81																								
0.15	42	42	42		51	52	52			61	61	63			72			77			81																							
0.18	42	42	43		51	52	52			61	61	63			72			77			82																							
0.22	42	43	43		52	52	52		61	61	62	64			71	72		76	77		81	82										91												
0.27	43	43	44		52	52	53		61	62	62			71	71	73		76	76	78	81	81	82									91												
0.33	43	44			52	53	53		61	62	62			71	71	73		76	76	78	81	81	82										91											
0.39	44				52	53	54		62	62	62		71	71	72	74	76	76	77	79	81	81	81	83									92											
0.47					53	54			62	62	63		71	71	72		76	76	77		81	81	81	83									92											
0.56					53				62	63	63		71	72	72		76	77	77		81	81	82	84										92										
0.68					54				62	63	64		72	72	72		77	77	77		81	82	82												92									
0.82									63	64			72	72	73		77	77	78		82	82	82												91	93								
1									63	64			72	72	73		77	77	78		82	82	82												91	91	93							
1.2									64				72	73	74		77	78	79		82	82	83												91	91	92	94						
1.5													73	73			78	78			82	83	83													91	92	92						
1.8													73	74			78	79			83	83	84														92	92	92					
2.2													74				79				83	84																92	92	92				
2.7																					84																		92	92	93			
3.3																																									92	93	93	
3.9																																										93	93	94
4.7																																										93	94	
5.6																																											94	

NB Figures in cells refer to size within ordering information

SMPS Capacitors (CH/CV Style)



European Preferred Styles

Chip Assemblies

X7R DIELECTRIC STABLE CERAMIC

Cap μ F	CH/CV41-44 Styles				CH/CV51-54 Styles				CH/CV61-64 Styles				CH/CV71-74 Styles				CH/CV76-79 Styles				CH81-84 Styles				CH86-89 Styles				CH91-94 Styles										
	50	100	200	500	50	100	200	500	50	100	200	500	50	100	200	500	50	100	200	500	50	100	200	500	50	100	200	500	50	100	200	500	50	100	200	500			
Voltage DC																																							
0.12				41																																			
0.15				41																																			
0.18				41																																			
0.22				41																																			
0.27				42								51																											
0.33				41	42							51																											
0.39				41	42							51																											
0.47				41	42							52				61																							
0.56				41	43							52				61																							
0.68				42	43							51	52			61																							
0.82				42	44							51	52			61					71			76				81											
1				41	42	44						51	53			61	62				71			76				81											
1.2				41	42							52	53			61	62				71			76				81											
1.5				41	43							52	54			61	62				71			76				81				86							
1.8	41	41	43									52				61	62				71	72			76	77					82	86							
2.2	41	41	44									51	52			61	63				71	72			76	77					81	82	86						
2.7	41	41										51	53			61	63				71	72			76	77					81	82	87	91					
3.3	41	42										51	53			61	64				71	72			76	77					81	82	87	91					
3.9	42	42										51	51	54			62				71	73			77	78					81	83	86	87	91				
4.7	42	42										51	52			61	62				71	73			77	78					81	83	86	87	91				
5.6	42	42										51	52			61	63				71	73			77	79					81	84	86	88	92				
6.8	42	43										52	52			61	61	63				71	73			77					81	82	86	88	92				
8.2	43	43										52	52			61	61	64				71	73			76	78				81	82	86	89	91	92			
10	43	44										52	53			61	62	64				71	73			76	78				81	83	87		91	92			
12	44											53	53			61	62				71	71	74			76	76	79			81	83		87	92	93			
15												53	54			61	62				71	71			76	76					81	81	84		86	87	92	93	
18												54				61	63				71	72			76	77					81	81		86	88		92	94	
22												54				61	63				71	72			76	77					81	82		86	86	88		92	
27																61	64				71	72			76	77					81	82		86	86	89		93	
33																61	64				71	73			76	78					81	82		86	87		91	93	
39																64					71	73			76	78					81	82		86	87		91	91	94
47																					71	73			76	78					81	82		86	87		91	92	
56																					71	73			76	78					81	83		86	87		91	92	
68																					71	73			76	78					81	83		86	87		91	92	
82																					71	73			76	78					81	84		86	88		91	92	
100																					71	73			76	78					81			86	88		91	92	
120																					71	73			76	78					81			86	89		92	93	
150																					71	73			76	78					81			86		91	92		
180																					71	73			76	78					81			86		91	92		

NB Figures in cells refer to size within ordering information

High Voltage Leded (CH Style)

Radial, Dual-in-Line & 'L' Lead SMT



European Preferred Styles

330 pF to 2.7 μ F
 1kV to 5kV
 -55°C to +125°C
 1B/C0G and 2C1/X7R Dielectrics

This range of radial, dual-in-line for both through hole and surface mount products is intended for use in high voltage power supplies and voltage multiplier circuits. The multilayer ceramic construction offers excellent volumetric efficiency compared with other high voltage dielectrics. They are suitable for both high reliability and industrial applications.

ELECTRICAL SPECIFICATIONS

Temperature Coefficient CECC 30 000, (4.24.1)

1B/C0G: A Temperature Coefficient - 0 ± 30 ppm/°C
 2C1/X7R: C Temperature Characteristic - $\pm 15\%$ (0v dc)

Capacitance Test 25°C

1B/C0G: Measured at 1 VRMS max at 1KHz (1MHz <100 pF)
 2C1/X7R: Measured at 1 VRMS max at 1KHz

Dissipation Factor 25°C

1B/C0G: 0.15% max at 1KHz, 1 VRMS (1MHz for <100 pF)
 2C1/X7R: 2.5% max at 1KHz, 1 VRMS

Insulation Resistance

1B/C0G & 2C1/X7R: 100K megohms or 1000 megohms- μ F, whichever is less

Dielectric Withstanding Voltage 25°C

130% rated voltage for 5 seconds

Life Test (1000 hrs) CECC 30000 (4.23)

1B/C0G & 2C1/X7R: 120% rated voltage at +125°C.

Aging

1B/C0G: Zero
 2C1/X7R: 2.5%/decade hour

DUAL-IN-LINE

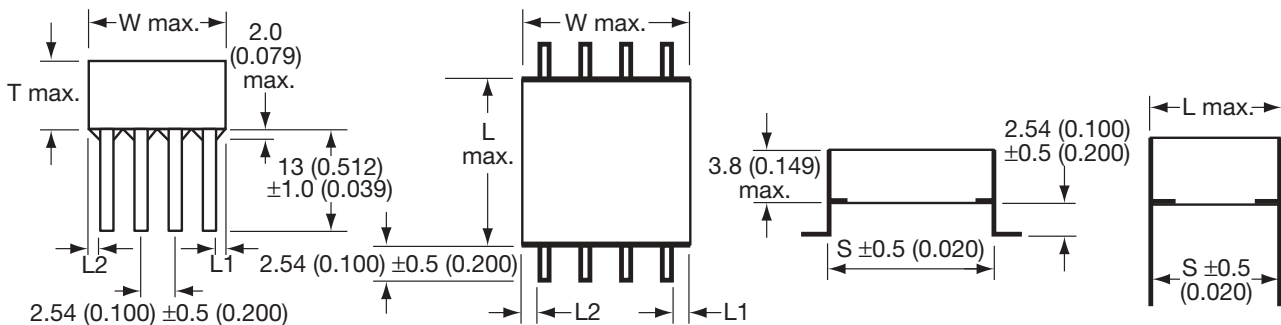

DIMENSIONS

millimeters (inches)

Style	L (max)	W (max)	S (nom)	No. of Leads per side
CH41	9.2 (0.362)	8.7 (0.342)	8.2 (0.323)	3
CH51	10.7 (0.421)	10.7 (0.421)	10.2 (0.400)	4
CH61	14.9 (0.587)	13.6 (0.535)	14.0 (0.551)	5
CH76	21.6 (0.850)	21.6 (0.850)	20.3* (0.800)	6
CH91	24.0 (0.944)	40.6 (1.598)	20.3* (0.800)	14

*Tolerance ± 0.8 (0.031)

HOW TO ORDER

CH	41	A	C	104	K	A	4	0	A	7
Style Code	Size Code	Voltage Code	Dielectric Code	Capacitance Code	Capacitance Tolerance	Specification Code	Finish Code	Lead Dia. Code	Lead Space Code	Lead Style Code
		A = 1kV G = 2kV H = 3kV J = 4kV K = 5kV	A = C0G C = X7R	(2 significant digits + no. of zeros) eg. 105 = 1 μ F 106 = 10 μ F 107 = 100 μ F	J = $\pm 5\%$ K = $\pm 10\%$ M = $\pm 20\%$ P = -0 +100%	A = Non customized	4 = Varnish	0 = Standard	A = Standard	0 = Dual in line straight 7 = Dual in line 'L' style



High Voltage Leaded (CV Style)

Chip Assemblies



European Preferred Styles

VERTICALLY MOUNTED RADIAL PRODUCT

Part Number format (CVxxxxxxxxxxS2)

Typical Part Number CV51AC154MA43S2

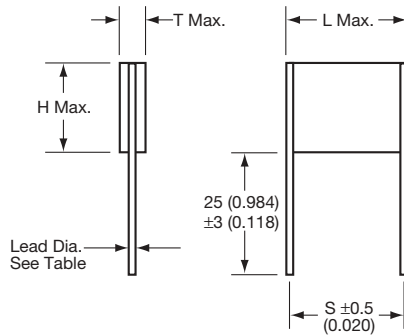

DIMENSIONS

millimeters (inches)

Style	L (max)	H (max)	T (max)	S (nom)	Lead Dia (nom)
CV41	10.6 (0.417)	8.70 (0.343)	3.80 (0.150)	8.20 (0.323)	0.70 (0.028)
CV51	11.9 (0.469)	10.7 (0.421)	3.80 (0.150)	10.2 (0.402)	0.90 (0.035)
CV61	16.5 (0.650)	13.6 (0.536)	3.80 (0.150)	15.2 (0.599)	0.90 (0.035)
CV76	22.7 (0.893)	16.6 (0.654)	3.80 (0.150)	21.2* (0.835)	0.90 (0.035)
CV91	22.7 (0.893)	40.6 (1.598)	3.80 (0.150)	21.2* (0.835)	1.20 (0.047)

*Tolerance $\pm 0.8\text{mm}$ (0.031)

HOW TO ORDER

CV	51	A	C	154	M	A	4	3	S	2
Style Code	Size Code	Voltage Code	Dielectric Code	Capacitance Code	Capacitance Tolerance	Specification Code	Finish Code	Lead Dia. Code	Lead Space Code	Lead Style Code
	A = 1kV G = 2kV H = 3kV J = 4kV K = 5kV	A = COG C = X7R	(2 significant digits + no. of zeros) eg. 105 = 1 μF 106 = 10 μF 107 = 100 μF	J = $\pm 5\%$ K = $\pm 10\%$ M = $\pm 20\%$ P = -0 +100%	A = Non customized	4 = Varnish (single chip assy.)	Standard	Standard		



High Voltage Leaded (CV/CH Style)



European Preferred Styles

Chip Assemblies

1B/C0G ULTRA STABLE CERAMIC

	CV41-CH41 Styles				CV51-CH51 Styles				CV61-CH61 Styles				CV76-CH76 Styles				CV91-CH91 Styles			
Cap pF																				
330				K																
390			J	K																
470			J	K																
560			J	K																
680			J					K												
820		H	J					K												
1000		H					J	K												
1200		H					J	K												
1500		H					J					K								
1800	G				H	J						K								
2200	G				H				J	K										
2700	G				H				J						K					
3300	G				G				H	J					K					
3900	G				G				H				J	K						
4700	G				G				H				J	K						
5600	A				G				H				J							K
6800	A				G			G					H	J						K
8200	A				G			G					H						J	K
10000	A				G			G					H						J	K
12000	A			A				G					H						J	K
15000	A			A				G			G						H	J		
18000				A				G			G						H	J		
22000				A			A				G						H			
27000				A			A				G						H			
33000				A			A				G						H			
39000							A				G					G				
47000							A				A					G				
56000							A				A					G				
68000							A				A					G				
82000											A					G				
100000											A					G				
120000																A				
150000																A				
180000																A				
220000																A				
270000																A				
330000																A				

NB Figures in cells refer to size within ordering information

High Voltage Leaded (CV/CH Style)



European Preferred Styles

Chip Assemblies

2C1/X7R STABLE CERAMIC

Cap nF	CV41-CH41 Styles		CV51-CH51 Styles			CV61-CH61 Styles			CV76-CH76 Styles			CV91-CH91 Styles		
1.2														
1.3														
1.5			J	K										
2.2			J	K										
2.7			J	K										
3.3			J					K						
3.9			J					K						
4.7			H	J			J						K	
5.6			H				J						K	
6.8			H				J						K	
8.2		G	H				J						K	
10		G				H			J	K				
12		G				H			J				K	
15		G				H			J				K	
18	A					G	H			H			J	K
22	A					G				H			J	
27	A					G				H			J	
33	A					G				H			J	
39	A					A				G	H		J	
47	A					A				G			H	
56	A					A				G			H	
68	A					A				G			H	
82	A					A				G			H	J
100	A					A			A				G	
120	A					A			A				G	
150						A			A				G	
180						A			A				G	H
220						A			A				G	
270						A			A				G	
330						A			A				G	
390						A			A				A	
470						A			A				A	
560						A			A				A	
680						A			A				A	
820						A			A				A	
1000						A			A				A	
1200						A			A				A	
1500						A			A				A	
1800						A			A				A	
2200						A			A				A	
2700						A			A				A	

NB Figures in cells refer to size within ordering information



A Dedicated Facility / BS9100 Requirements

Baseline Products — A Selection of Options

As a matter of course, AVX maintains a level of quality control that is sufficient to guarantee whatever reliability specifications are needed. However, AVX goes further. There are over 65 quality control and inspection operations that are available as options to a customer. Any number may be requested and written into a baseline process. The abbreviated list that follows indicates the breadth and thoroughness of available Q.C. services at AVX:

Ultrasonic Scanning
Destructive Physical Analysis (DPA)
X-Ray
Bondability Testing
Sorting and Matching to
Specification Limits
Temperature and Immersion
Cycling
Load/Humidity Life Testing
Dye Penetration Evaluation
100% Ceramic Sheet Inspection
Voltage Conditioning
Termination Pull Testing
Pre-encapsulation Inspection

Within the “specials” area, AVX accommodates a broad variety of customer needs. The AVX facilities are capable of developing and producing the most reliable and advanced MLCs available anywhere in the world today. Yet it is equally adept at making volume “custom” components that may differ only in

markings or lead placement from the standard catalog part.

Stretching the Limits

Advanced Products are developed to meet the extraordinary needs of specific applications. Requirements may include: low ESR, low ESL, voltages up to 10’s of thousands, advanced decoupling designs for frequencies up to 10’s of megahertz, temperatures up to 200°C, extremely high current discharge, ability to perform in high radiation or toxic atmospheres, or minimizing piezoelectric effect in high vibration environments.

In addition, solving customer packaging problems, aside from addressing circuit problems, is available. Special lead frames for high current or special mounting requirements are examples. Multiple ceramic chip package designs per customer requirements are also available.

Advanced Products always begin with a joint development program involving AVX and the customer. In undersea cable components, for example, capacitance and impedance ratings had to be maintained within 1% over the multi-year life of the system. In this case, Advanced Products not only met the parametric requirements of the customer, but accelerated life testing of 3,500 units indicated an average life expectancy of over 100,000 years.

Baseline Program Management

Baseline Program Management has been AVX’s forte over the years. This is both a product and a service function designed to provide the customer the full capabilities of AVX in meeting their program requirements. AVX has had Baseline and Program Management in the following major systems:

—AT&T Undersea Cable
—Minuteman
—Peacekeeper
—STC Undersea Cable
—CIT Undersea Cable
—Raytheon-Hawk Missile
—Trident
—Small Missile Program
—Northrop - Peacekeeper
—Sparrow Program
—Space Station
—European Space Agency (ESA)
—Commercial Satellite Program
—Arianne 4 & 5
—EuroFighter (Typhoon)
—EH101 (Merlin)

AVX technical personnel stand ready to answer any questions and provide any information required on your programs from the most exotic Hi-Rel part to the simplest variation on a standard. Put the experience, technology and facilities of the leading company in multilayer ceramics to work for you. No other source offers the unique combination of capability and commitment to advanced application specific components.

PROCUREMENT OF COMPONENTS OF BS9100 (CH/CV RANGE 50-500V)

The manufacturing facilities have ISO9001 approval. Customers requiring BS9100 approved components are requested to follow these steps:

1. The customer shall submit a specification for the required components to AVX for approval. Once agreed a Customer Detail Specification (CDS) number will be allocated by AVX to this specification. This number with its current revision must be quoted at the time of order placement.
2. If the customer has no specification, then AVX will supply a copy of the standard CDS for the customer’s approval and signature. As in 1 above, when agreed this CDS number must be quoted at order entry. In the event of agreement not being reached the component cannot be supplied to BS9100.

For assistance contact: EMAP Specification Engineering
Dept. AVX Ltd. Coleraine, Northern Ireland
Telephone ++44 (0)28703 44188, Fax ++44 (0)28703 55527

PACKAGING

Unless otherwise stated in the appropriate data sheet parts are supplied in a waffle pack.

ESA Qualified SMPS Capacitors



High Voltage Chip/Leaded Capacitors

HIGH VOLTAGE CHIP CAPACITORS

Capacitors, Fixed, Chip, Ceramic Dielectric, Type II, High Voltage, Based on Styles 1812 and 1825 for use in ESA space programs, according to ESA/SCC Generic Specification 3009 and associated Detail Specification 3009/034 as recommended by the Space Components Coordination Group. (ranges in table below)

Note: Variants 01 to 12: metallized pads

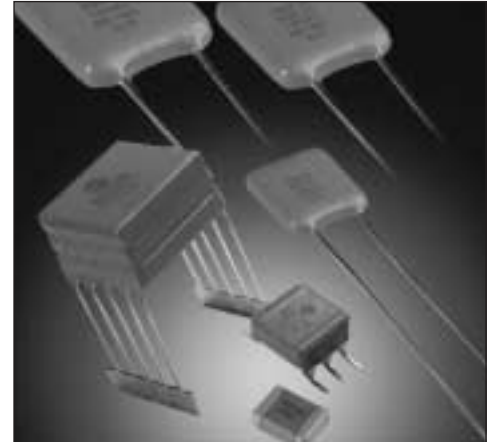

Size	Variant	Rated Voltage (kV)	Tolerance (%)	Capacitance Code (E12)
1812	01	1.0	±10	392 - 223
	02		±20	
	03		±10	
	04	2.0	±10	152 - 182
	05		±20	
	06	3.0	±10	821 - 102
1825	07	1.0	±10	273 - 563
	08		±20	
	09		±10	
	10	2.0	±10	222 - 682
	11		±20	
	12	3.0	±10	821 - 392

HOW TO ORDER

Parts should be ordered using the ESA variant number as follows:

3009034

XX

B

XXX

Detail Spec Number

Type Variant (per table)

Test Level

C = Standard test level
B = Level C plus serialized and capacitance before and after 100% burning.

Capacitance Code

The first two digits represent significant figures and the third digit specifies the number of zeros to follow; i.e.

102 = 1000pF
103 = 10000pF

Eg 300903401C223 = with level C testing

HIGH VOLTAGE LEADED CAPACITORS

Capacitors, Fixed, Ceramic Dielectric, Type II, High Voltage, 1.0 to 5.0 kV, Based on Case Styles VR, CV and CH for use in ESA space programs, according to ESA/SCC Generic Specification 3001 and associated Detail Specification 3001/034 as recommended by the Space Components Coordination Group. (ranges in table)

Note 1: Lead Types

- a - Leaded Radial (epoxy coated)
- b - Leaded Radial (Polyurethane Varnish)
- c - Straight Dual in Line
- d - L Dual in Line

Note 2: Tolerances of ±10% and ±20% are available

Case Size	Variant	Lead Type	Capacitance Code (E12)				
			1.0kV	2.0kV	3.0kV	4.0kV	5.0kV
VR30S	01	a	392 - 203	152 - 182	821 - 102		
VR30	02	a	273 - 563	222 - 682	821 - 392		
VR40	03	a	473 - 124	822 - 153	472 - 103	182 - 222	
VR50	04	a	154 - 274	183 - 333	123 - 183	562 - 822	332 - 392
VR66	05	a	224 - 564	393 - 823	223 - 393	103 - 153	682 - 103
VR84	06	a	684 - 105	473 - 154	473 - 683	183 - 393	123 - 183
VR90	07	a	125 - 275	184 - 334	823 - 184	473 - 124	223 - 563
CV41	08	b	473 - 124	822 - 153	472 - 103	182 - 222	
CH41	09	c	473 - 124	822 - 153	472 - 103	182 - 222	
CH41	10	d	473 - 124	822 - 153	472 - 103	182 - 222	
CV51	11	b	154 - 274	183 - 333	123 - 183	562 - 822	332 - 392
CH51	12	c	154 - 274	183 - 333	123 - 183	562 - 822	332 - 392
CH51	13	d	154 - 274	183 - 333	123 - 183	562 - 822	332 - 392
CV61	14	b	224 - 564	393 - 823	223 - 393	103 - 153	682 - 103
CH61	15	c	224 - 564	393 - 823	223 - 393	103 - 153	682 - 103
CH61	16	d	224 - 564	393 - 823	223 - 393	103 - 153	682 - 103
CV76	17	b	684 - 105	473 - 154	473 - 683	183 - 393	123 - 183
CH76	18	c	684 - 105	473 - 154	473 - 683	183 - 393	123 - 183
CH76	19	d	684 - 105	473 - 154	473 - 683	183 - 393	123 - 183
CV91	20	b	125 - 275	184 - 334	823 - 184	473 - 124	223 - 563
CH91	21	c	125 - 275	184 - 334	823 - 184	473 - 124	223 - 563
CH91	22	d	125 - 275	184 - 334	823 - 184	473 - 124	223 - 563

HOW TO ORDER

Parts should be ordered using the ESA variant number as follows:

3001034

XX

B

Detail Spec Number

Type Variant (per table above)

Test Level
C = Standard test level
B = VR's are x-rayed.

XXX

Capacitance Code

The first two digits represent significant figures and the third digit specifies the number of zeros to follow; i.e.

102 = 1000pF
103 = 10000pF

K

Capacitance Tolerance

K = 10%
M = 20%

X

Voltage

M = 1kV
P = 2kV
R = 3kV
S = 4kV
Z = 5kV

Eg 300103412C274KM = level C testing



ESA Qualified SMPS Capacitors



European Preferred Styles

High Capacitance

HIGH CAPACITANCE LEADED CAPACITORS

Capacitors, Fixed, Ceramic Dielectric, Type II, High Capacitance, Based on Case Styles BR, CV and CH for use in ESA space programs, according to ESA/SCC Generic Specification 3001 and associated Detail Specification 3001/030 as recommended by the Space Components Coordination Group. (see ranges in table below)

Note 1: Lead Types

- a - Leaded Radial (epoxy coated)
- b - Leaded Radial (Polyurethane Varnish)
- c - Straight Dual in Line
- d - L Dual in Line

Note 2: Tolerances of $\pm 10\%$ and $\pm 20\%$ are available

Case Size	Variant	Figure	Capacitance Code (E12)			
			50V	100V	200V	500V
BR40	01	a	185 - 335	125 - 395	334 - 564	124 - 224
BR50	02	a	395 - 565	225 - 395	684 - 105	274 - 394
BR66	03	a	685 - 106	475 - 825	105 - 225	474 - 105
BR72	04	a	126 - 186	825 - 156	225 - 335	824 - 155
BR84	05	a	126 - 186	825 - 156	225 - 335	824 - 155
CV41	06	b	185 - 335	125 - 275	334 - 564	124 - 224
CH41	07	c	185 - 335	125 - 275	334 - 564	124 - 224
CH41	08	d	185 - 335	125 - 275	334 - 564	124 - 224
CH42	09	c	395 - 565	225 - 395	684 - 105	274 - 394
CH42	10	d	395 - 565	225 - 395	684 - 105	274 - 394
CH43	11	c	825 - 106	685 - 825	155 - 185	564 - 684
CH43	12	d	825 - 106	685 - 825	155 - 185	564 - 684
CH44	13	c	126	106	225	824 - 105
CH44	14	d	126	106	225	824 - 105
CV51	15	b	395 - 565	225 - 395	684 - 105	274 - 394
CH51	16	c	395 - 565	225 - 395	684 - 105	274 - 394
CH51	17	d	395 - 565	225 - 395	684 - 105	274 - 394
CH52	18	c	685 - 106	475 - 825	125 - 225	474 - 824
CH52	19	d	685 - 106	475 - 825	125 - 225	474 - 824
CH53	20	c	126 - 156	106 - 126	275 - 335	105 - 125
CH53	21	d	126 - 156	106 - 126	275 - 335	105 - 125
CH54	22	c	186 - 226	156	395	155
CH54	23	d	186 - 226	156	395	155
CV61	24	b	685 - 106	475 - 825	105 - 225	474 - 105
CH61	25	c	685 - 106	475 - 825	105 - 225	474 - 105
CH61	26	d	685 - 106	475 - 825	105 - 225	474 - 105
CH62	27	c	126 - 226	106 - 156	275 - 475	105 - 185
CH62	28	d	126 - 226	106 - 156	275 - 475	105 - 185
CH63	29	c	276 - 336	186 - 226	565 - 685	225 - 275
CH63	30	d	276 - 336	186 - 226	565 - 685	225 - 275
CH64	31	c	396	276 - 336	825 - 106	335
CH64	32	d	396	276 - 336	825 - 106	335
CV71	33	b	126 - 186	825 - 156	225 - 335	824 - 155
CH71	34	c	126 - 186	825 - 156	225 - 335	824 - 155
CH71	35	d	126 - 186	825 - 156	225 - 335	824 - 155
CH72	36	c	226 - 396	186 - 276	395 - 685	185 - 335
CH72	37	d	226 - 396	186 - 276	395 - 685	185 - 335

Case Size	Variant	Figure	Capacitance Code (E12)			
			50V	100V	200V	500V
CH73	38	c	476 - 566	336 - 396	825 - 106	395 - 475
CH73	39	d	476 - 566	336 - 396	825 - 106	395 - 475
CH74	40	c	686	476	126	565
CH74	41	d	686	476	126	565
CV76	42	b	126 - 186	825 - 156	225 - 335	824 - 155
CH76	43	c	126 - 186	825 - 156	225 - 335	824 - 155
CH76	44	d	126 - 186	825 - 156	225 - 335	824 - 155
CH77	45	c	226 - 396	186 - 276	395 - 685	185 - 335
CH77	46	d	226 - 396	186 - 276	395 - 685	185 - 335
CH78	47	c	476 - 566	336 - 396	825 - 106	395 - 475
CH78	48	d	476 - 566	336 - 396	825 - 106	395 - 475
CH79	49	c	686	476	126	565
CH79	50	d	686	476	126	565
CH81	51	c	156 - 226	126 - 186	225 - 395	824 - 155
CH81	52	d	156 - 226	126 - 186	225 - 395	824 - 155
CH82	53	c	276 - 476	226 - 396	475 - 825	
CH82	54	d	276 - 476	226 - 396	475 - 825	
CH83	55	c	566 - 686	476 - 566	10 - 12	
CH83	56	d	566 - 686	476 - 566	10 - 12	
CH84	57	c	826	686	156	
CH84	58	d	826	686	156	
CH86	59	c	226 - 336	156 - 276	395 - 685	155 - 225
CH86	60	d	226 - 336	156 - 276	395 - 685	155 - 225
CH87	61	c	396 - 686	336 - 566	825 - 156	
CH87	62	d	396 - 686	336 - 566	825 - 156	
CH88	63	c	826 - 107	686 - 826	186 - 226	
CH88	64	d	826 - 107	686 - 826	186 - 226	
CH89	65	c	127	107	276	
CH89	66	d	127	107	276	
CH91	67	c	396 - 476	336 - 396	825 - 106	
CH91	68	d	396 - 476	336 - 396	825 - 106	
CH92	69	c	566 - 107	476 - 826	126 - 226	
CH92	70	d	566 - 107	476 - 826	126 - 226	
CH93	71	c	127 - 157	107 - 127	276 - 336	
CH93	72	d	127 - 157	107 - 127	276 - 336	
CH94	73	c	187	157	396	
CH94	74	d	187	157	396	

HOW TO ORDER

Parts should be ordered using the ESA variant number as follows:

3001030

Detail Spec Number

XX

Type Variant (per table above)

B

Test Level

- C = Standard test level
- B = Level C + 100% capacitance test before and after burn-in, then serialized and capacitance recorded. VR's are x-rayed.

XXX

Capacitance Code

The first two digits represent significant figures and the third digit specifies the number of zeros to follow; i.e.

- 102 = 1000pF
- 103 = 10000pF

K

Capacitance Tolerance

- K = 10%
- M = 20%

X

Voltage

- C = 50V
- E = 100V
- G = 200V
- L = 500V

EG 300103018C106KC = CH525C106KE (level C testing)

Lot Acceptance Testing is available for all our ESA qualified ranges.

- LAT 1 42 samples → 12 mechanical + 20 life test + 6 for TC + 4 for solder
- LAT 2 30 samples → 20 life test + 6 for TC + 4 for solder
- LAT 3 10 samples → 6 for TC + 4 for solder



PASSIVES

Capacitors

- Multilayer Ceramic
- Tantalum
- Microwave
- Glass
- Film
- Power Film
- Power Ceramic
- Ceramic Disc
- Trimmer
- BestCap™

Resistors

- Chips
- Arrays
- Potentiometers

Timing Devices

- Resonators
- Oscillators
- Crystals

Filters

- EMI
- Bulk
- SAW
- Dielectric

Thin Film

- Inductors
- Fuses
- Capacitors
- Couplers
- Baluns
- Filters

Integrated Passive Components

- Low Inductance Chip Arrays
- “Z” Chips
- Capacitor Arrays
- Dual Resonance Chips
- Custom IPCs

Voltage Suppressors, Varistors and Thermistors

Acoustical Piezos

Ferrites

CONNECTORS

- 2mm Hard-Metric for CompactPCI®
- Automotive Connectors
- Board to Board Connectors – SMT and Through-Hole
- Card Edge
- Compression
- Custom Designed Connectors
- Customized Backpanel, Racking and Harnessing Services
- DIN 41612 Connectors
- FFC/FPC Connectors
- Insulation Displacement Connectors
- I/O Connectors
- Memory Card Connectors
CF, PCMCIA, SD, MMC
- MOBO™, I/O, Board to Board and Battery Connectors
- Press-fit Connectors
- Varicon®
- Wire to Board, Crimp or IDC

**For more information please visit
our website at**

<http://www.avxcorp.com>

NOTICE: Specifications are subject to change without notice. Contact your nearest AVX Sales Office for the latest specifications. All statements, information and data given herein are believed to be accurate and reliable, but are presented without guarantee, warranty, or responsibility of any kind, expressed or implied. Statements or suggestions concerning possible use of our products are made without representation or warranty that any such use is free of patent infringement and are not recommendations to infringe any patent. The user should not assume that all safety measures are indicated or that other measures may not be required. Specifications are typical and may not apply to all applications.

© AVX Corporation

USA

AVX Myrtle Beach, SC
Corporate Offices
Tel: 843-448-9411
FAX: 843-448-1943

AVX North Central, IN
Tel: 317-848-7153
FAX: 317-844-9314

AVX Southwest, AZ
Tel: 480-539-1496
FAX: 480-539-1501

AVX Southeast, GA
Tel: 404-608-8151
FAX: 770-972-0766

AVX Northwest, WA
Tel: 360-699-8746
FAX: 360-699-8751

AVX Mid/Pacific, MN
Tel: 952-974-9155
FAX: 952-974-9179

AVX South Central, TX
Tel: 972-669-1223
FAX: 972-669-2090

AVX Canada
Tel: 905-564-8959
FAX: 905-564-9728

EUROPE

AVX Limited, England
European Headquarters
Tel: ++44 (0) 1252-770000
FAX: ++44 (0) 1252-770001

AVX/ELCO, England
Tel: ++44 (0) 1638-675000
FAX: ++44 (0) 1638-675001

AVX S.A., France
Tel: ++33 (1) 69-18-46-00
FAX: ++33 (1) 69-28-73-87

AVX GmbH, Germany
Tel: ++49 (0) 8131-9004-0
FAX: ++49 (0) 8131-9004-44

AVX srl, Italy
Tel: ++390 (0)2 614-571
FAX: ++390 (0)2 614-2576

AVX Czech Republic
Tel: ++420 (0) 465-358-111
FAX: ++420 (0) 465-323-010

ASIA-PACIFIC

AVX/Kyocera, Singapore
Asia-Pacific Headquarters
Tel: (65) 6286-7555
FAX: (65) 6488-9880

AVX/Kyocera, Hong Kong
Tel: (852) 2-363-3303
FAX: (852) 2-765-8185

AVX/Kyocera, Korea
Tel: (82) 2-785-6504
FAX: (82) 2-784-5411

AVX/Kyocera, Taiwan
Tel: (886) 2-2698-8778
FAX: (886) 2-2698-8777

AVX/Kyocera, Malaysia
Tel: (60) 4-228-1190
FAX: (60) 4-228-1196

Elco, Japan
Tel: 045-943-2906/7
FAX: 045-943-2910

Kyocera, Japan - AVX
Tel: (81) 75-604-3426
FAX: (81) 75-604-3425

Kyocera, Japan - KDP
Tel: (81) 75-604-3424
FAX: (81) 75-604-3425

AVX/Kyocera, Shanghai, China
Tel: 86-21 6886 1000
FAX: 86-21 6886 1010

AVX/Kyocera, Tianjin, China
Tel: 86-22 2576 0098
FAX: 86-22 2576 0096

Contact:

