

### FEATURES

- High Slew Rate – 170 V/ $\mu$ s
- Wide Bandwidth – 28 MHz
- Fast Settling Time – <200 ns to 0.01%
- Low Offset Voltage – <500  $\mu$ V
- Unity-Gain Stable
- Low Voltage Operation  $\pm 5$  V to  $\pm 15$  V
- Low Supply Current – <10 mA
- Drives Capacitive Loads

### APPLICATIONS

- High Speed Image Display Drivers
- High Frequency Active Filters
- Fast Instrumentation Amplifiers
- High Speed Detectors
- Integrators
- Photo Diode Preamps

### GENERAL DESCRIPTION

The OP467 is a quad, high speed, precision operational amplifier. It offers the performance of a high speed op amp combined with the advantages of a precision operational amplifier all in a single package. The OP467 is an ideal choice for applications where, traditionally, more than one op amp was used to achieve this level of speed and precision.

The OP467's internal compensation ensures stable unity-gain operation, and it can drive large capacitive loads without oscillation. With a gain bandwidth product of 28 MHz driving a 30 pF load, output slew rate in excess of 170 V/ $\mu$ s, and settling time to 0.01% in less than 200 ns, the OP467 provides excellent dynamic accuracy in high speed data-acquisition systems. The channel-to-channel separation is typically 60 dB at 10 MHz.

The dc performance of OP467 includes less than 0.5 mV of offset, voltage noise density below 6 nV/ $\sqrt{\text{Hz}}$ , and total supply current under 10 mA. Common-mode rejection and power supply rejection ratios are typically 85 dB. PSRR is maintained to better than 40 dB with input frequencies as high as 1 MHz. The low offset and drift plus high speed and low noise make the OP467 usable in applications such as high speed detectors and instrumentation.

The OP467 is specified for operation from  $\pm 5$  V to  $\pm 15$  V over the extended industrial temperature range ( $-40^{\circ}\text{C}$  to  $+85^{\circ}\text{C}$ ) and is available in 14-lead plastic and ceramic DIP, and 16-lead SOIC and 20-terminal LCC surface-mount packages.

Contact your local sales office for MIL-STD-883 data sheet and availability.

### PIN CONNECTIONS

14-Lead Ceramic DIP (Y Suffix) and  
14-Lead Plastic DIP (P Suffix)

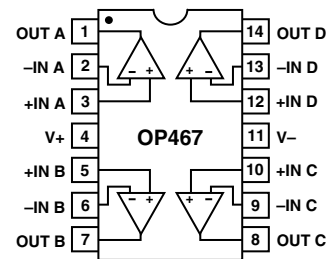

16-Lead SOIC  
(S Suffix)

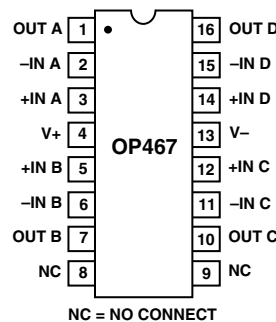

20-Terminal LCC  
(RC Suffix)

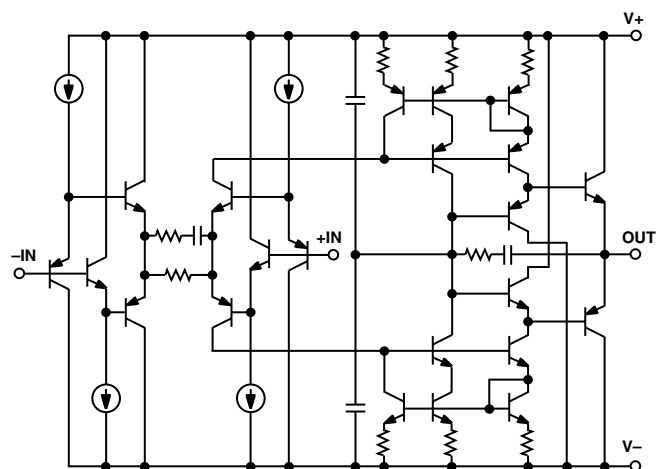
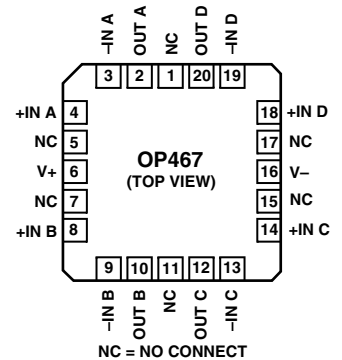

Figure 1. Simplified Schematic

REV. E

Information furnished by Analog Devices is believed to be accurate and reliable. However, no responsibility is assumed by Analog Devices for its use, nor for any infringements of patents or other rights of third parties that may result from its use. No license is granted by implication or otherwise under any patent or patent rights of Analog Devices. Trademarks and registered trademarks are the property of their respective owners.

# OP467—SPECIFICATIONS

## ELECTRICAL CHARACTERISTICS (@ $V_S = \pm 15.0\text{ V}$ , $T_A = 25^\circ\text{C}$ unless otherwise noted.)

Parameter	Symbol	Conditions	Min	Typ	Max	Unit
<b>INPUT CHARACTERISTICS</b>						
Offset Voltage	$V_{OS}$	$-40^\circ\text{C} \leq T_A \leq +85^\circ\text{C}$		0.2	0.5	mV
Input Bias Current	$I_B$	$V_{CM} = 0\text{ V}$		150	600	nA
Input Offset Current	$I_{OS}$	$V_{CM} = 0\text{ V}, -40^\circ\text{C} \leq T_A \leq +85^\circ\text{C}$		150	700	nA
Common-Mode Rejection	$CMR$	$V_{CM} = 0\text{ V}$		10	100	nA
	$CMR$	$V_{CM} = \pm 12\text{ V}, -40^\circ\text{C} \leq T_A \leq +85^\circ\text{C}$	80	90		dB
Large Signal Voltage Gain	$A_{VO}$	$R_L = 2\text{ k}\Omega$	80	88		dB
	$A_{VO}$	$R_L = 2\text{ k}\Omega, -40^\circ\text{C} \leq T_A \leq +85^\circ\text{C}$	83	86		dB
Offset Voltage Drift	$\Delta V_{OS}/\Delta T$			3.5		$\mu\text{V}/^\circ\text{C}$
Bias Current Drift	$\Delta I_B/\Delta T$			0.2		$\text{pA}/^\circ\text{C}$
Long-Term Offset Voltage Drift	$\Delta V_{OS}/\Delta T$	Note 1			750	$\mu\text{V}$
<b>OUTPUT CHARACTERISTICS</b>						
Output Voltage Swing	$V_O$	$R_L = 2\text{ k}\Omega$	$\pm 13.0$	$\pm 13.5$		V
		$R_L = 2\text{ k}\Omega, -40^\circ\text{C} \leq T_A \leq +85^\circ\text{C}$	$\pm 12.9$	$\pm 13.12$		V
<b>POWER SUPPLY<sup>2</sup></b>						
Power Supply Rejection Ratio	PSRR	$\pm 4.5\text{ V} \leq V_S \leq \pm 18\text{ V}$	96	120		dB
		$-40^\circ\text{C} \leq T_A \leq +85^\circ\text{C}$	86	115		dB
Supply Current	$I_{SY}$	$V_O = 0\text{ V}$		8	10	mA
Supply Voltage Range	$V_S$	$V_O = 0\text{ V}, -40^\circ\text{C} \leq T_A \leq +85^\circ\text{C}$			13	mA
			$\pm 4.5$		$\pm 18$	V
<b>DYNAMIC PERFORMANCE</b>						
Gain Bandwidth Product	GBP	$A_V = +1, C_L = 30\text{ pF}$		28		MHz
Slew Rate	SR	$V_{IN} = 10\text{ V Step}, R_L = 2\text{ k}\Omega, C_L = 30\text{ pF}$				
		$A_V = +1$	125	170		V/ $\mu\text{s}$
		$A_V = -1$				V/ $\mu\text{s}$
Full-Power Bandwidth	$BW_p$	$V_{IN} = 10\text{ V Step}$		2.7		MHz
Settling Time	$t_S$	To 0.01%, $V_{IN} = 10\text{ V Step}$		200		ns
Phase Margin	$\theta_0$			45		Degrees
Input Capacitance						
Common Mode				2.0		pF
Differential				1.0		pF
<b>NOISE PERFORMANCE</b>						
Voltage Noise	$e_N$ p-p	$f = 0.1\text{ Hz to }10\text{ Hz}$		0.15		$\mu\text{V p-p}$
Voltage Noise Density	$e_N$	$f = 1\text{ kHz}$		6		$\text{nV}/\sqrt{\text{Hz}}$
Current Noise Density	$i_N$	$f = 1\text{ kHz}$		8		$\text{pA}/\sqrt{\text{Hz}}$

### NOTES

<sup>1</sup>Long-Term Offset Voltage Drift is guaranteed by 1000 hrs. Life test performed on three independent wafer lots at  $125^\circ\text{C}$ , with an LTPD of 1.3.

<sup>2</sup>For proper operation the positive supply must be sequenced ON before the negative supply.

Specifications subject to change without notice.

**ELECTRICAL CHARACTERISTICS** (@  $V_S = \pm 5.0\text{ V}$ ,  $T_A = 25^\circ\text{C}$  unless otherwise noted.)

Parameter	Symbol	Conditions	Min	Typ	Max	Unit
<b>INPUT CHARACTERISTICS</b>						
Offset Voltage	$V_{OS}$	$-40^\circ\text{C} \leq T_A \leq +85^\circ\text{C}$		0.3	0.5	mV
Input Bias Current	$I_B$	$V_{CM} = 0\text{ V}$		125	600	nA
Input Offset Current	$I_{OS}$	$V_{CM} = 0\text{ V}, -40^\circ\text{C} \leq T_A \leq +85^\circ\text{C}$		150	700	nA
Common-Mode Rejection	CMR	$V_{CM} = 0\text{ V}$		20	100	nA
		$V_{CM} = 0\text{ V}, -40^\circ\text{C} \leq T_A \leq +85^\circ\text{C}$			150	nA
Common-Mode Rejection	CMR	$V_{CM} = \pm 2.0\text{ V}$	76	85		dB
Common-Mode Rejection	CMR	$V_{CM} = \pm 2.0\text{ V}, -40^\circ\text{C} \leq T_A \leq +85^\circ\text{C}$	76	80		dB
Large Signal Voltage Gain	$A_{VO}$	$R_L = 2\text{ k}\Omega$	80	83		dB
Large Signal Voltage Gain		$R_L = 2\text{ k}\Omega, -40^\circ\text{C} \leq T_A \leq +85^\circ\text{C}$	74			dB
Offset Voltage Drift	$\Delta V_{OS}/\Delta T$			3.5		$\mu\text{V}/^\circ\text{C}$
Bias Current Drift	$\Delta I_B/\Delta T$			0.2		$\text{pA}/^\circ\text{C}$
<b>OUTPUT CHARACTERISTICS</b>						
Output Voltage Swing	$V_O$	$R_L = 2\text{ k}\Omega$	$\pm 3.0$	$\pm 3.5$		V
Output Voltage Swing		$R_L = 2\text{ k}\Omega, -40^\circ\text{C} \leq T_A \leq +85^\circ\text{C}$	$\pm 3.0$	$\pm 3.20$		V
<b>POWER SUPPLY</b>						
Power Supply Rejection Ratio	PSRR	$\pm 4.5\text{ V} \leq V_S \leq \pm 5.5\text{ V}$	92	107		dB
Power Supply Rejection Ratio		$-40^\circ\text{C} \leq T_A \leq +85^\circ\text{C}$	83	105		dB
Supply Current	$I_{SY}$	$V_O = 0\text{ V}$		8	10	mA
Supply Current		$V_O = 0\text{ V}, -40^\circ\text{C} \leq T_A \leq +85^\circ\text{C}$			12	mA
<b>DYNAMIC PERFORMANCE</b>						
Gain Bandwidth Product	GBP	$A_V = +1$		22		MHz
Slew Rate	SR	$V_{IN} = 5\text{ V Step}, R_L = 2\text{ k}\Omega, C_L = 39\text{ pF}$				
Slew Rate		$A_V = +1$		90		V/ $\mu\text{s}$
Slew Rate		$A_V = -1$		90		V/ $\mu\text{s}$
Full-Power Bandwidth	$BW_p$	$V_{IN} = 5\text{ V Step}$		2.5		MHz
Settling Time	$t_s$	$T_o 0.01\%, V_{IN} = 5\text{ V Step}$		280		ns
Phase Margin	$\theta_0$			45		Degrees
<b>NOISE PERFORMANCE</b>						
Voltage Noise	$e_N$ p-p	$f = 0.1\text{ Hz to }10\text{ Hz}$		0.15		$\mu\text{V p-p}$
Voltage Noise Density	$e_N$	$f = 1\text{ kHz}$		7		$\text{nV}/\sqrt{\text{Hz}}$
Current Noise Density	$i_N$	$f = 1\text{ kHz}$		8		$\text{pA}/\sqrt{\text{Hz}}$

Specifications subject to change without notice.

# OP467

## WAFER TEST LIMITS<sup>1</sup> (@ $V_S = \pm 15.0\text{ V}$ , $T_A = 25^\circ\text{C}$ unless otherwise noted.)

Parameter	Symbol	Conditions	Limit	Unit
Offset Voltage	$V_{OS}$		$\pm 0.5$	mV max
Input Bias Current	$I_B$	$V_{CM} = 0\text{ V}$	600	nA max
Input Offset Current	$I_{OS}$	$V_{CM} = 0\text{ V}$	100	nA max
Input Voltage Range <sup>2</sup>			$\pm 12$	V min/max
Common-Mode Rejection Ratio	CMRR	$V_{CM} = \pm 12\text{ V}$	80	dB min
Power Supply Rejection Ratio	PSRR	$V = \pm 4.5\text{ V to } \pm 18\text{ V}$	96	dB min
Large Signal Voltage Gain	$A_{VO}$	$R_L = 2\text{ k}\Omega$	83	dB min
Output Voltage Range	$V_O$	$R_L = 2\text{ k}\Omega$	$\pm 13.0$	V min
Supply Current	$I_{SY}$	$V_O = 0\text{ V}, R_L = \infty$	10	mA max

### NOTES

<sup>1</sup>Electrical tests and wafer probe to the limits shown. Due to variations in assembly methods and normal yield loss, yield after packaging is not guaranteed for standard product dice. Consult factory to negotiate specifications based on dice lot qualifications through sample lot assembly and testing.

<sup>2</sup>Guaranteed by CMR test.

### ABSOLUTE MAXIMUM RATINGS<sup>1</sup>

Supply Voltage <sup>2</sup>	$\pm 18\text{ V}$
Input Voltage <sup>3</sup>	$\pm 18\text{ V}$
Differential Input Voltage <sup>3</sup>	$\pm 26\text{ V}$
Output Short-Circuit Duration	Limited
Storage Temperature Range	
Y, RC Packages	$-65^\circ\text{C to } +175^\circ\text{C}$
P, S Packages	$-65^\circ\text{C to } +150^\circ\text{C}$
Operating Temperature Range	
OP467A	$-55^\circ\text{C to } +125^\circ\text{C}$
OP467G	$-40^\circ\text{C to } +85^\circ\text{C}$
Junction Temperature Range	
Y, RC Packages	$-65^\circ\text{C to } +175^\circ\text{C}$
P, S Packages	$-65^\circ\text{C to } +150^\circ\text{C}$
Lead Temperature Range (Soldering, 60 sec)	$300^\circ\text{C}$

Package Type	$\theta_A^4$	$\theta_{JC}$	Unit
14-Lead Cerdip (Y)	94	10	$^\circ\text{C/W}$
14-Lead PDIP (P)	76	33	$^\circ\text{C/W}$
16-Lead SOIC (S)	88	23	$^\circ\text{C/W}$
20-Terminal LCC (RC)	78	33	$^\circ\text{C/W}$

### NOTES

<sup>1</sup>Absolute maximum ratings apply to both DICE and packaged parts, unless otherwise noted.

<sup>2</sup>For proper operation the positive supply must be sequenced ON before the negative supply.

<sup>3</sup>For supply voltages less than  $\pm 18\text{ V}$ , the absolute maximum input voltage is equal to the supply voltage.

<sup>4</sup> $\theta_{JA}$  is specified for the worst-case conditions, i.e.,  $\theta_{JA}$  is specified for device in socket for cerdip, P-DIP, and LCC packages;  $\theta_{JA}$  is specified for device soldered in circuit board for SOIC package.

### ORDERING GUIDE

Model	Temperature Ranges	Package Descriptions	Package Options
OP467ARC/883C	$-55^\circ\text{C to } +125^\circ\text{C}$	20-Terminal LCC	RC-Suffix (E-20A)
OP467AY/883C	$-55^\circ\text{C to } +125^\circ\text{C}$	14-Lead Cerdip	Y-Suffix (Q-14)
OP467GBC		DIE	
OP467GP	$-40^\circ\text{C to } +85^\circ\text{C}$	14-Lead PDIP	P-Suffix (N-14)
OP467GS	$-40^\circ\text{C to } +85^\circ\text{C}$	16-Lead SOIC	S-Suffix (RW-16)
OP467GS-REEL	$-40^\circ\text{C to } +85^\circ\text{C}$	16-Lead SOIC	S-Suffix (RW-16)

### DICE CHARACTERISTICS

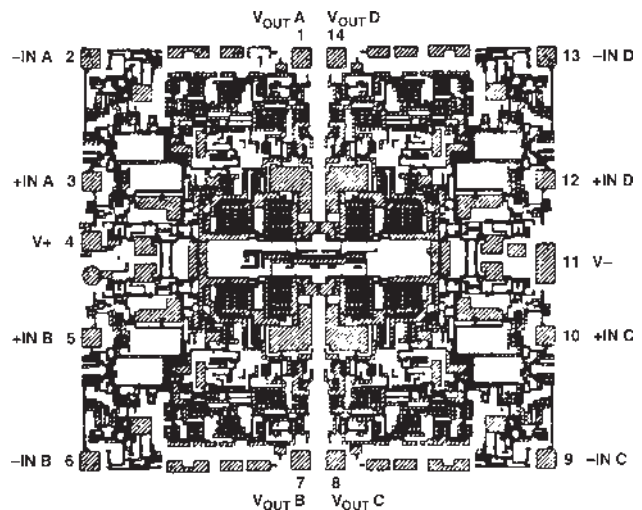

OP467 Die Size  $0.111 \times 0.100$  inch, 11,100 sq. mils Substrate is Connected to  $V_+$ , Number of Transistors 165

# Typical Performance Characteristics—OP467

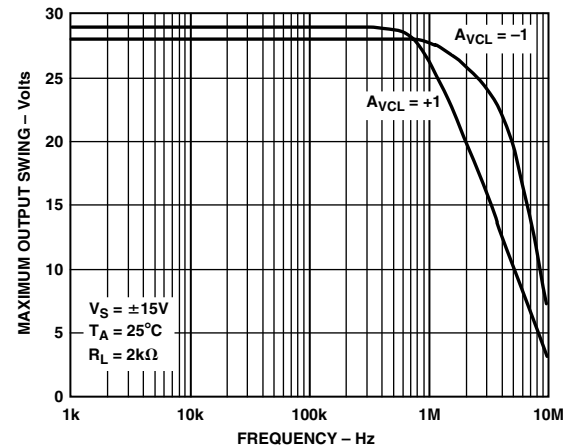
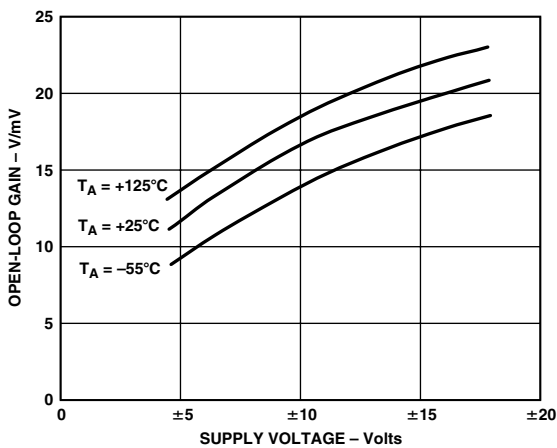
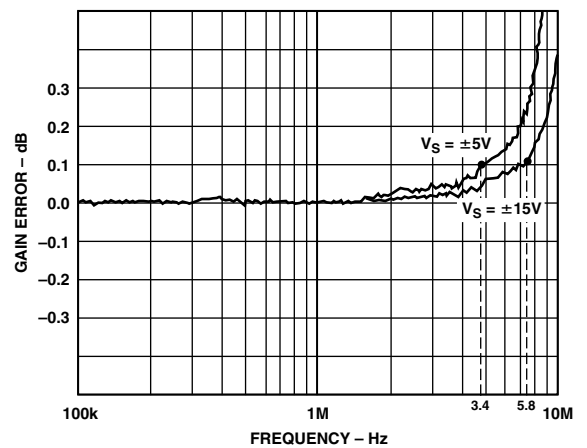
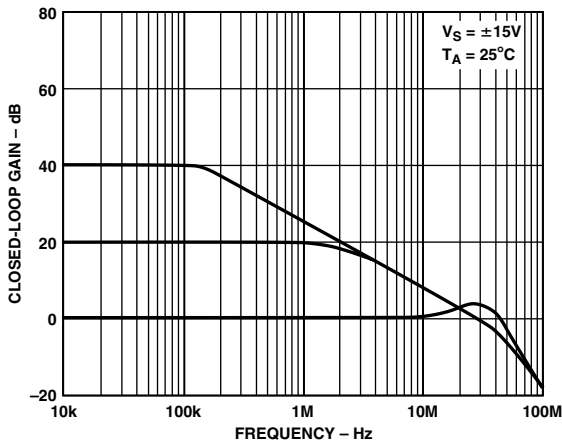
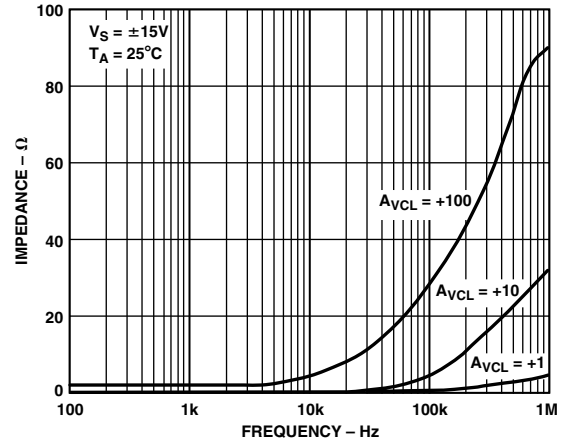
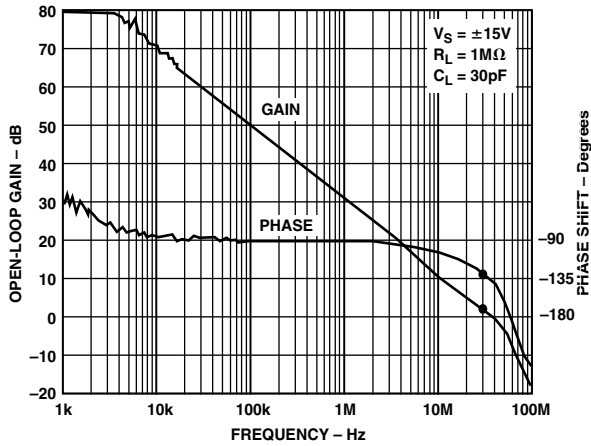

# OP467

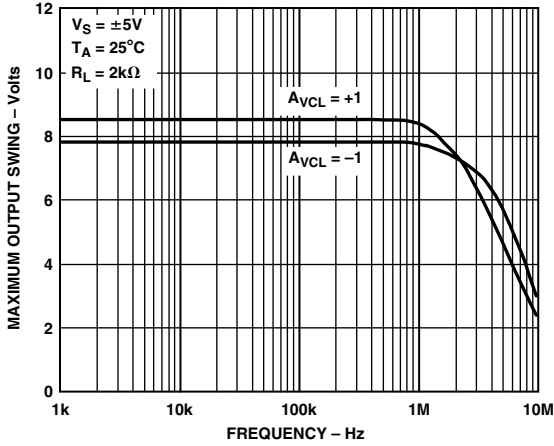

TPC 7. Max  $V_{OUT}$  Swing vs. Frequency

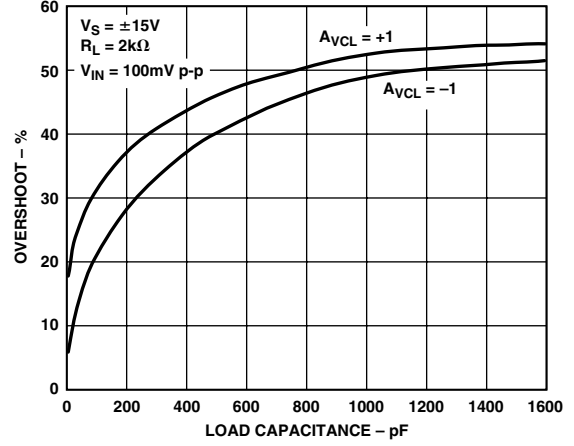

TPC 10. Small Signal Overshoot vs. Load Capacitance

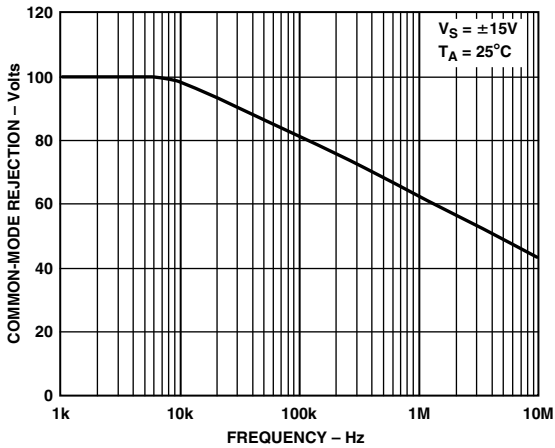

TPC 8. Common-Mode Rejection vs. Frequency

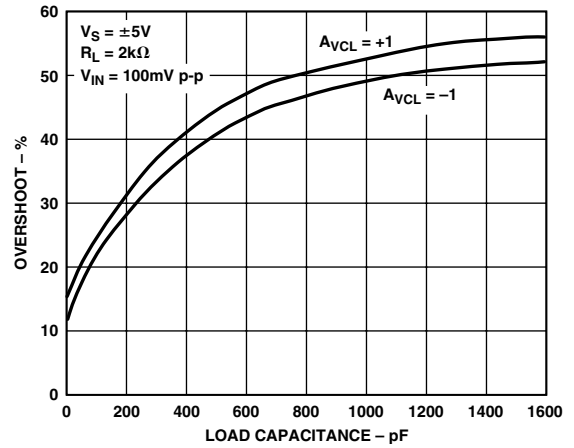

TPC 11. Small Signal Overshoot vs. Load Capacitance

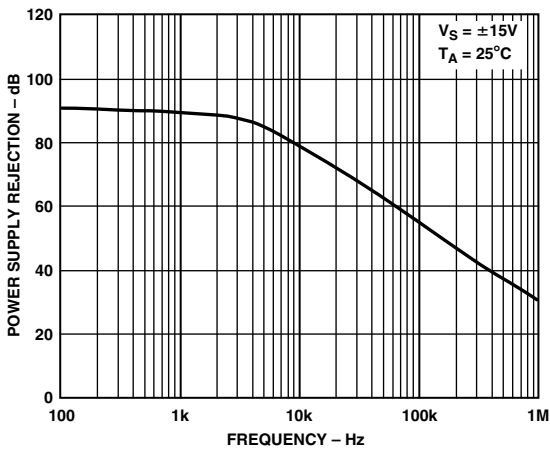

TPC 9. Power-Supply Rejection vs. Frequency

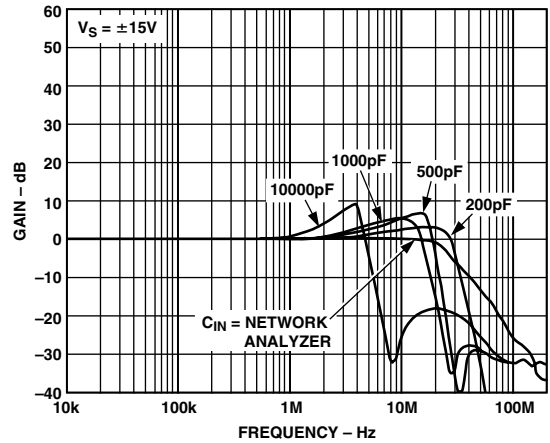

TPC 12. Noninverting Gain vs. Capacitive Loads

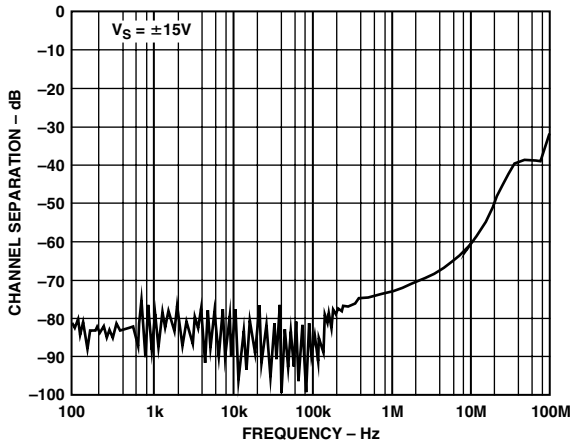

TPC 13. Channel Separation vs. Frequency

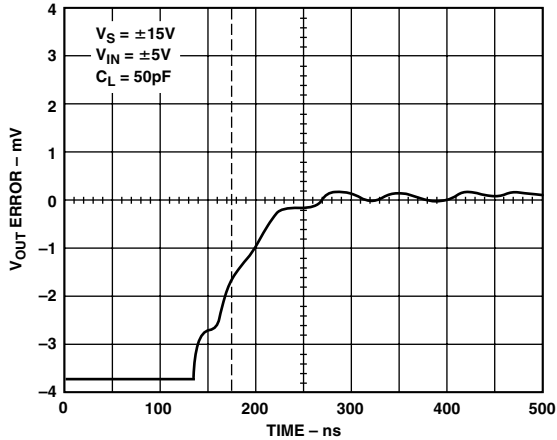

TPC 16. Settling Time, Negative Edge

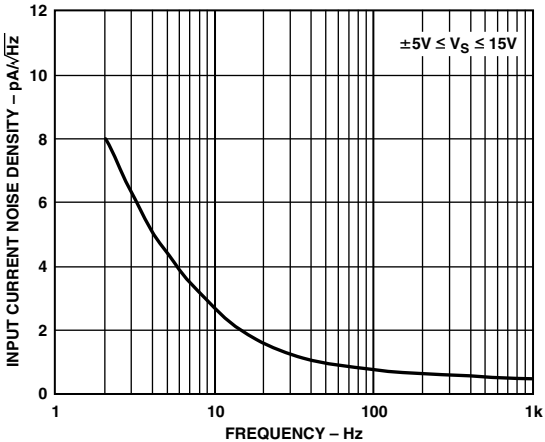

TPC 14. Input Current Noise Density vs. Frequency

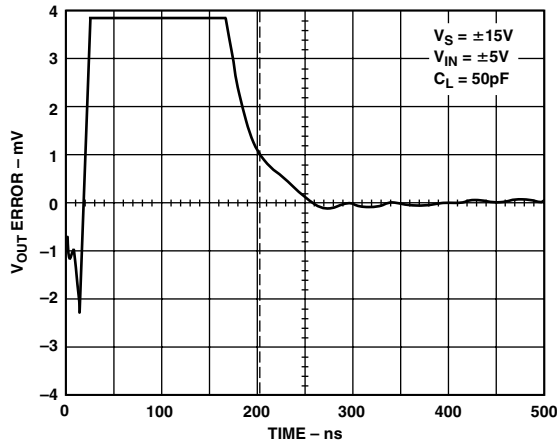

TPC 17. Settling Time, Positive Edge

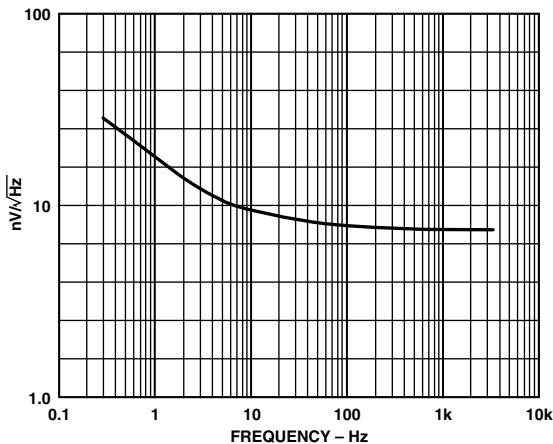

TPC 15. Voltage Noise Density vs. Frequency

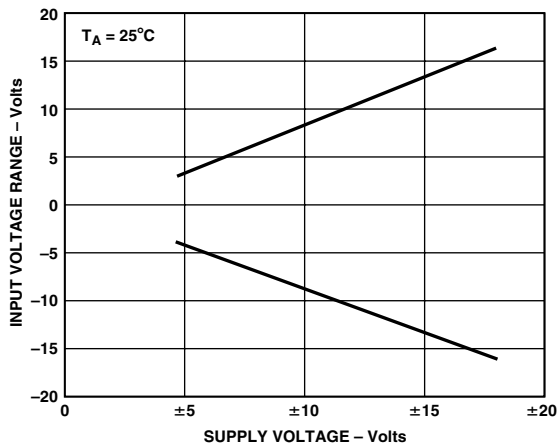

TPC 18. Input Voltage Range vs. Supply Voltage

# OP467

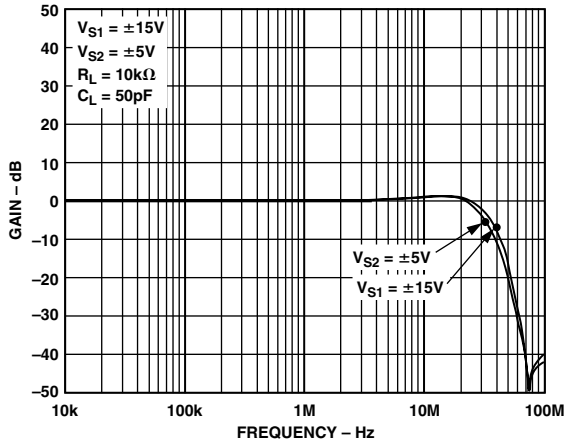

TPC 19. Noninverting Gain vs. Supply Voltage

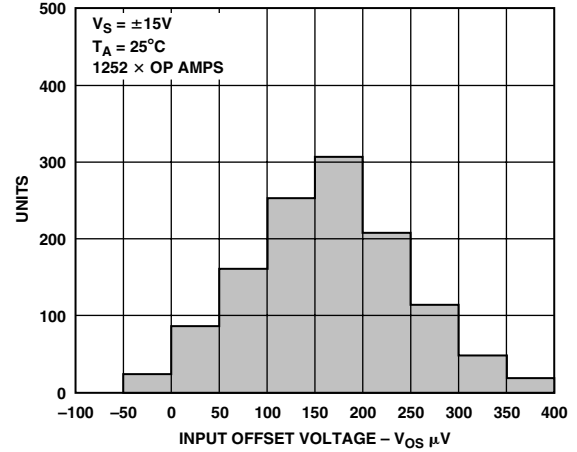

TPC 22. Input Offset Voltage Distribution

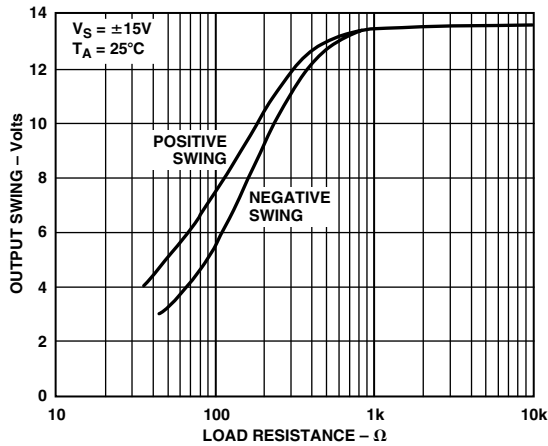

TPC 20. Output Swing vs. Load Resistance

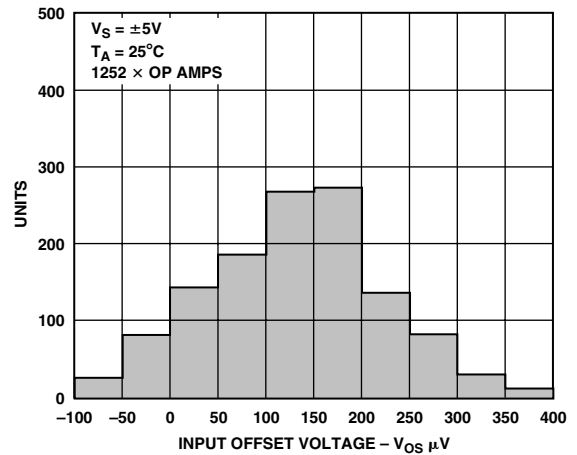

TPC 23. Input Offset Voltage Distribution

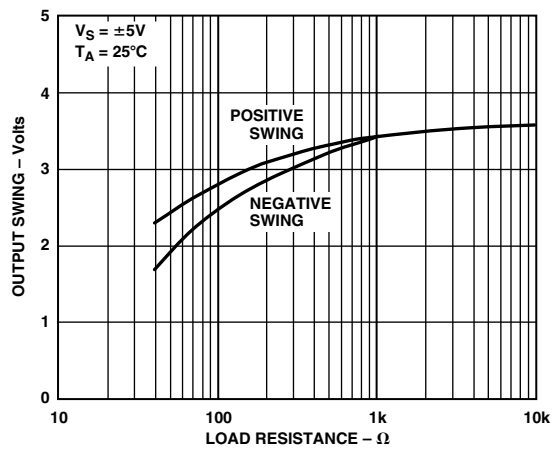

TPC 21. Output Swing vs. Load Resistance

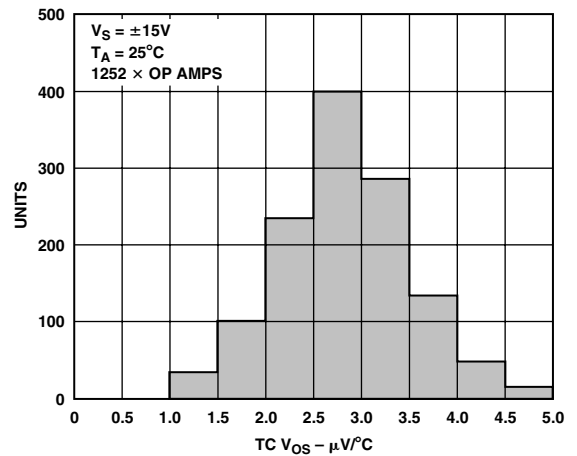

TPC 24. TC  $V_{OS}$  Distribution



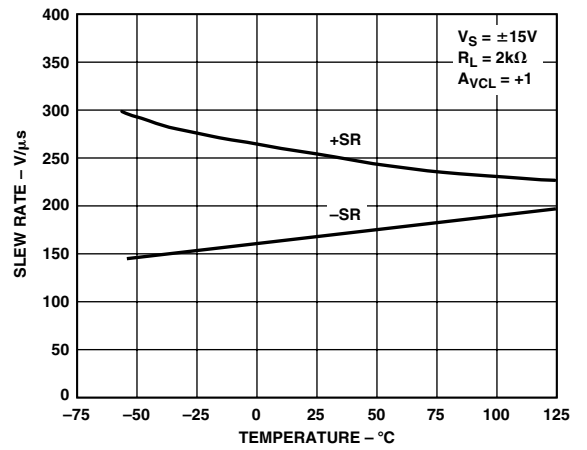
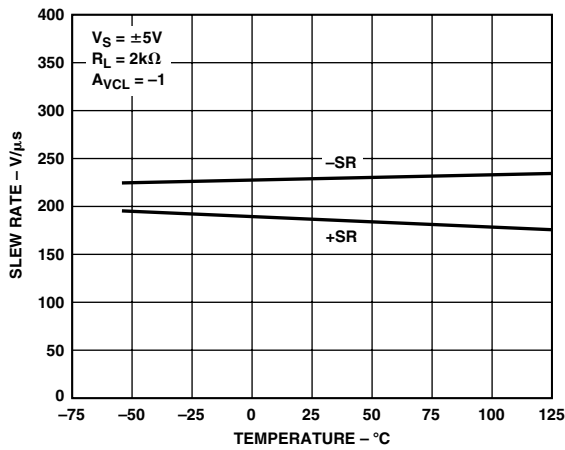
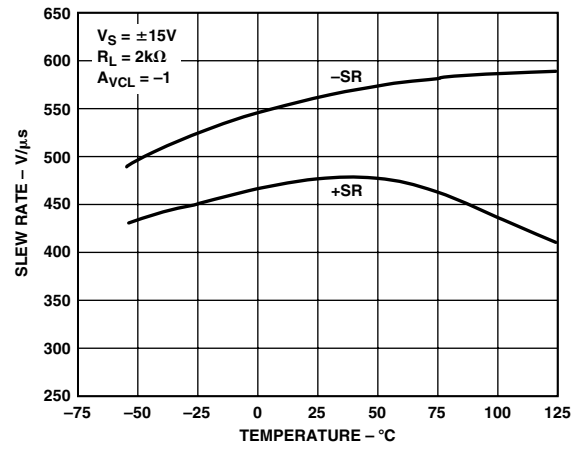
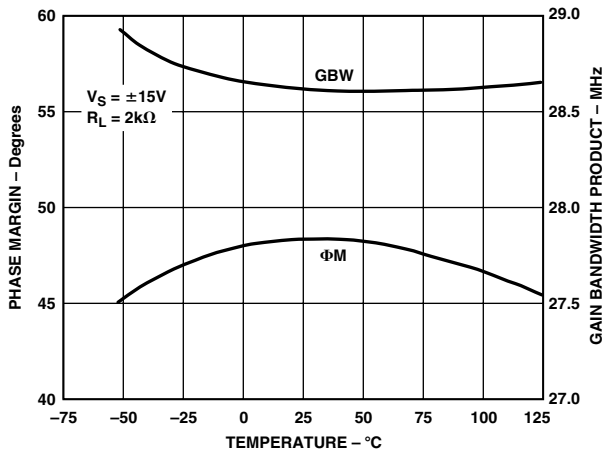
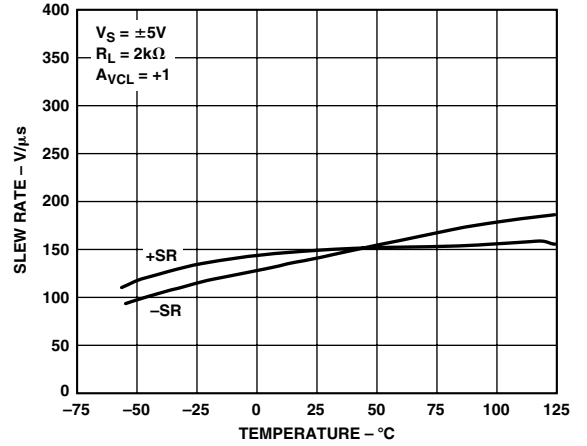
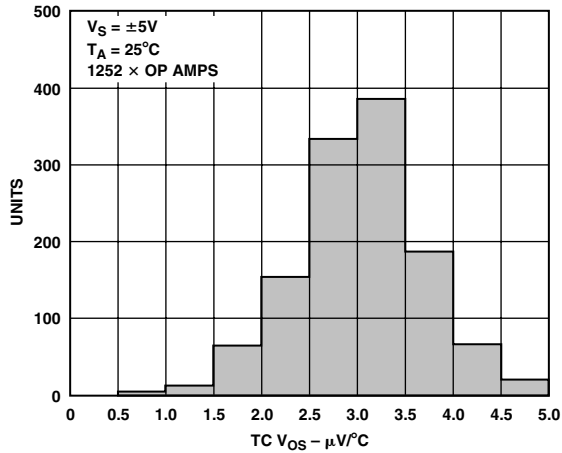

# OP467

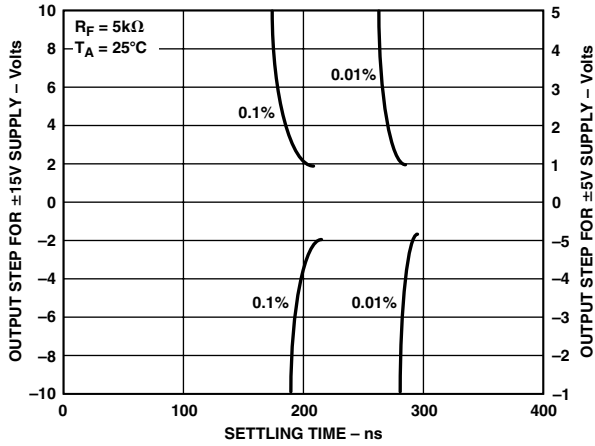

TPC 31. Settling Time vs. Output Step

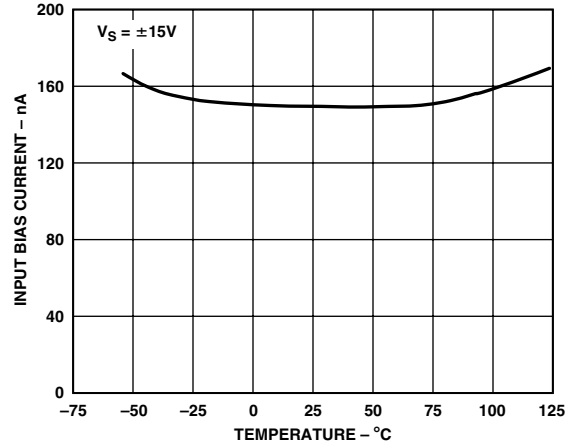

TPC 33. Input Bias Current vs. Temperature

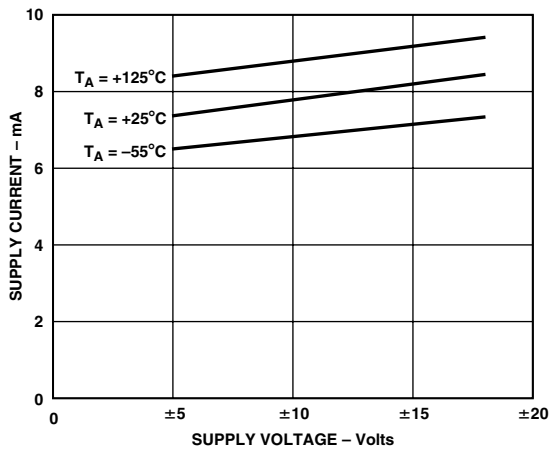

TPC 32. Supply Current vs. Supply Voltage

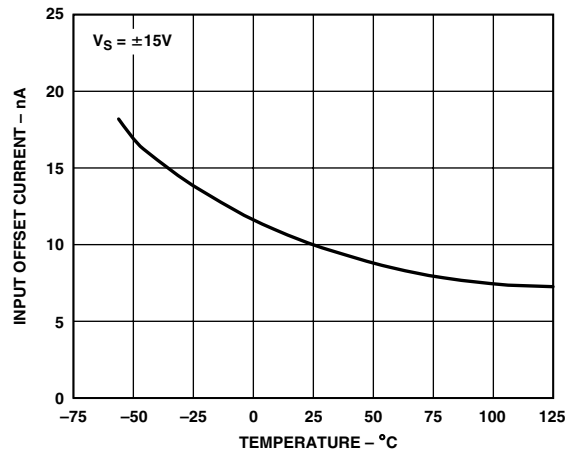

TPC 34. Input Offset Current vs. Temperature

## APPLICATIONS INFORMATION

### Output Short-Circuit Performance

To achieve a wide bandwidth and high slew rate, the OP467 output is *not* short-circuit protected. Shorting the output to ground or to the supplies may destroy the device.

For safe operation, the output load current should be limited so that the junction temperature does not exceed the absolute maximum junction temperature.

To calculate the maximum internal power dissipation, the following formula can be used:

$$P_D = \frac{T_J \text{ max} - T_A}{\theta_{JA}}$$

where  $T_J$  and  $T_A$  are junction and ambient temperatures, respectively,  $P_D$  is device internal power dissipation, and  $\theta_{JA}$  is packaged device thermal resistance given in the data sheet.

### Unused Amplifiers

It is recommended that any unused amplifiers in a quad package be connected as a unity-gain follower with a 1 k $\Omega$  feedback resistor with noninverting input tied to the ground plain.

### Printed Circuit Board Layout Considerations

Satisfactory performance of a high speed op amp largely depends on a good PC layout. To achieve the best dynamic performance, following high frequency layout technique is recommended.

### Grounding

A good ground plain is essential to achieve the optimum performance in high speed applications. It can significantly reduce the undesirable effects of ground loops and IR drops by providing a low impedance reference point. Best results are obtained with a multilayer board design with one layer assigned to ground plain. To maintain a continuous and low impedance ground, avoid running any traces on this layer.

### Power Supply Considerations

For proper operation the positive supply must be sequenced ON before the negative supply. All users should take steps to ensure this. In high frequency circuits, device lead length introduces an inductance in series with the circuit. This inductance, combined with stray capacitance, forms a high frequency resonance circuit. Poles generated by these circuits will cause gain peaking and additional phase shift, reducing the op amp's phase margin and leading to an unstable operation.

A practical solution to this problem is to reduce the resonance frequency low enough to take advantage of the amplifier's power supply rejection.

This is easily done by placing capacitors across the supply line and the ground plain as close as possible to the device pin. Since capacitors also have internal parasitic components, such as stray inductance, selecting the right capacitor is important. To be effective, they should have low impedance over the frequency range of interest. Tantalum capacitors are an excellent choice for their high capacitance/size ratio, but their ESR (effective series resistance) increases with frequency making them less

effective. On the other hand, ceramic chip capacitors have excellent ESR and ESL (effective series inductance) performance at higher frequencies, and because of their small size, they can be placed very close to the device pin, further reducing the stray inductance. Best results are achieved by using a combination of these two capacitors. A 5  $\mu\text{F}$ –10  $\mu\text{F}$  tantalum parallel with a 0.1  $\mu\text{F}$  ceramic chip cap is recommended. If additional isolation from high frequency resonances of the power supply is needed, a ferrite bead should be placed in series with the supply lines between the bypass caps and the power supply. A word of caution: addition of the ferrite bead will introduce a new pole and zero to frequency response of the circuit and could cause unstable operation if it is not selected properly.

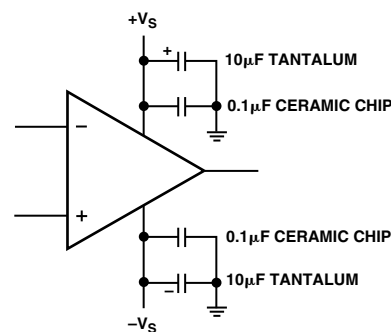

Figure 2. Recommended Power Supply Bypass

### Signal Considerations

Input and output traces need special attention to assure a minimum stray capacitance. Input nodes are very sensitive to capacitive reactance, particularly when connected to a high impedance circuit. Stray capacitance can inject undesirable signals from a noisy line into a high impedance input. Protect high impedance input traces by providing guard traces around them. This will also improve the channel separation significantly.

Additionally, any stray capacitance in parallel with the op amp's input capacitance generates a pole in the frequency response of the circuit. The additional phase shift caused by this pole will reduce the circuit's gain margin. If this pole is within the gain range of the op amp, it will cause unstable performance. To reduce these undesirable effects, use the lowest impedance where possible. Lowering the impedance at this node places the poles at a higher frequency, far above the gain range of the amplifier. Stray capacitance on the PC board can be reduced by making the traces narrow and as short as possible. Further reduction can be realized by choosing smaller pad size, increasing the spacing between the traces, and using PC board material with a low dielectric constant insulator (dielectric constant of some common insulators: air = 1, Teflon<sup>®</sup> = 2.2, and FR4 = 4.7; with air being an ideal insulator).

Removing segments of the ground plain directly under the input and output pads is recommended.

Outputs of high speed amplifiers are very sensitive to capacitive loads. A capacitive load will introduce a pair of pole and zero to the circuit's frequency response, reducing the phase margin, leading to unstable operation or oscillation.

# OP467

Generally, it is good design practice to isolate the amplifier's output from any capacitive load by placing a resistor between the amplifier's output and the rest of the circuits. A series resistor of 10 Ω to 100 Ω is normally sufficient to isolate the output from a capacitive load.

The OP467 is internally compensated to provide stable operation, and is capable of driving large capacitive loads without oscillation.

Sockets are not recommended since they increase the lead inductance/capacitance and reduce the power dissipation of the package by increasing the leads' thermal resistance. If sockets must be used, use Teflon or pin sockets with the shortest possible leads.

## Phase Reversal

The OP467 is immune to phase reversal; its inputs can exceed the supply rails by a diode drop without any phase reversal.

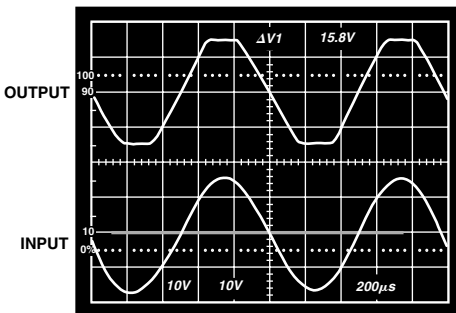

Figure 3. No Phase Reversal ( $A_V = +1$ )

## Saturation Recovery Time

The OP467 has a fast and symmetrical recovery time from either rail. This feature is very useful in applications such as high speed instrumentation and measurement circuits, where the amplifier is frequently exposed to large signals that overload the amplifier.

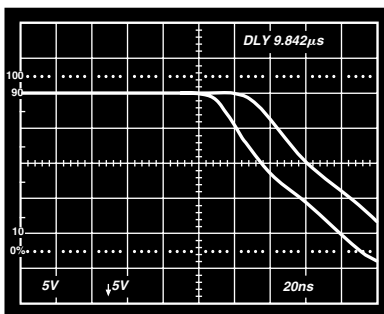

Figure 4. Saturation Recovery Time, Positive Rail

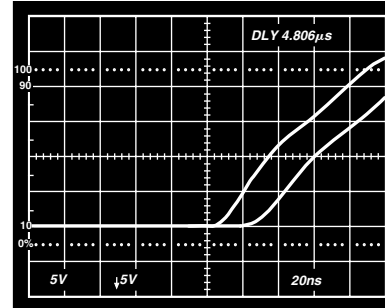

Figure 5. Saturation Recovery Time, Negative Rail

## High Speed Instrumentation Amplifier

The OP467 performance lends itself to a variety of high speed applications, including high speed precision instrumentation amplifiers. Figure 6 represents a circuit commonly used for data acquisition, CCD imaging, and other high speed applications.

Circuit gain is set by  $R_G$ . A 2 kΩ resistor will set the circuit gain to 2; for unity gain, remove  $R_G$ . For any other gain settings use the following formula:

$$G = 2/R_G \quad \text{Resistor Value is in k}\Omega$$

$R_C$  is used for adjusting the dc common-mode rejection, and  $C_C$  is used for ac common-mode rejection adjustments.

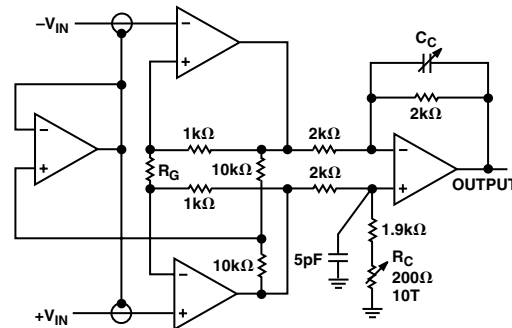

Figure 6. A High Speed Instrumentation Amplifier

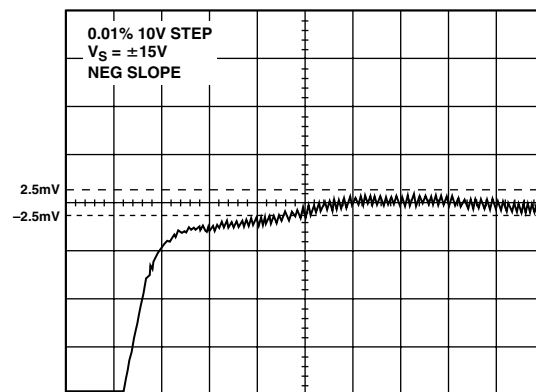

Figure 7. Instrumentation Amplifier Settling Time to 0.01% for a 10 V Step Input (Negative Slope)

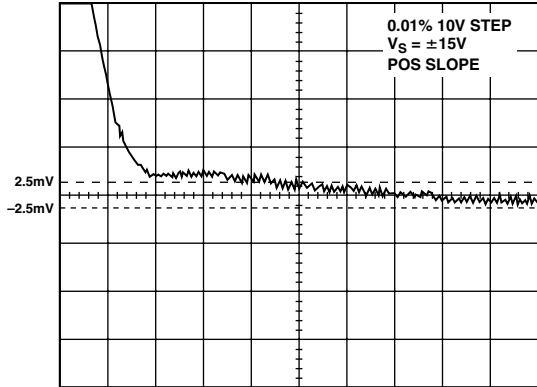

Figure 8. Instrumentation Amplifier Settling Time to 0.01% for a 10 V Step Input (Positive Slope)

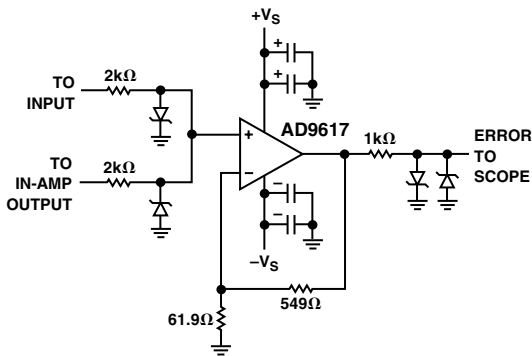

Figure 9. Settling Time Measurement Circuit

**2 MHz Biquad Bandpass Filter**

The circuit in Figure 10 is commonly used in medical imaging ultrasound receivers. The 30 MHz bandwidth is sufficient to accurately produce the 2 MHz center frequency, as the measured response shows in Figure 11. When the op amp’s bandwidth is too close to the filter’s center frequency, the amplifier’s internal phase shift causes excess phase shift at 2 MHz, which alters the filter’s response. In fact, if the chosen op amp has a bandwidth close to 2 MHz, the combined phase shift of the three op amps will cause the loop to oscillate.

Careful consideration must be given to the layout of this circuit as with any other high speed circuit.

If the phase shift introduced by the layout is large enough, it could alter the circuit performance, or worse, it will oscillate.

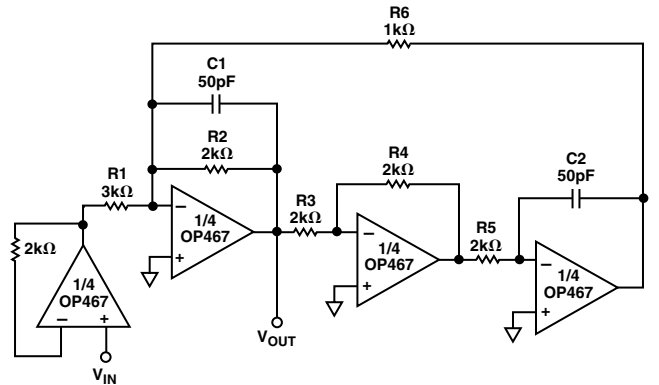

Figure 10. 2 MHz Biquad Filter

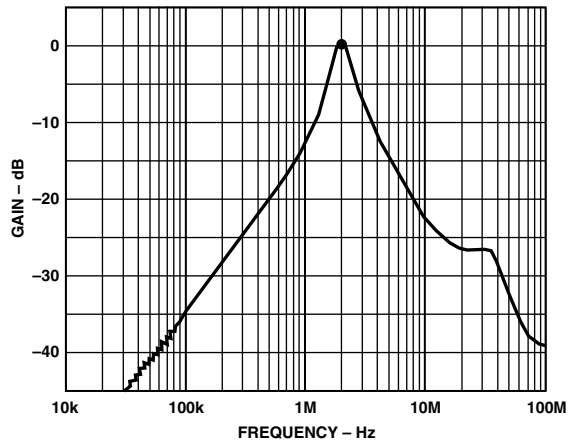

Figure 11. Biquad Filter Response

# OP467

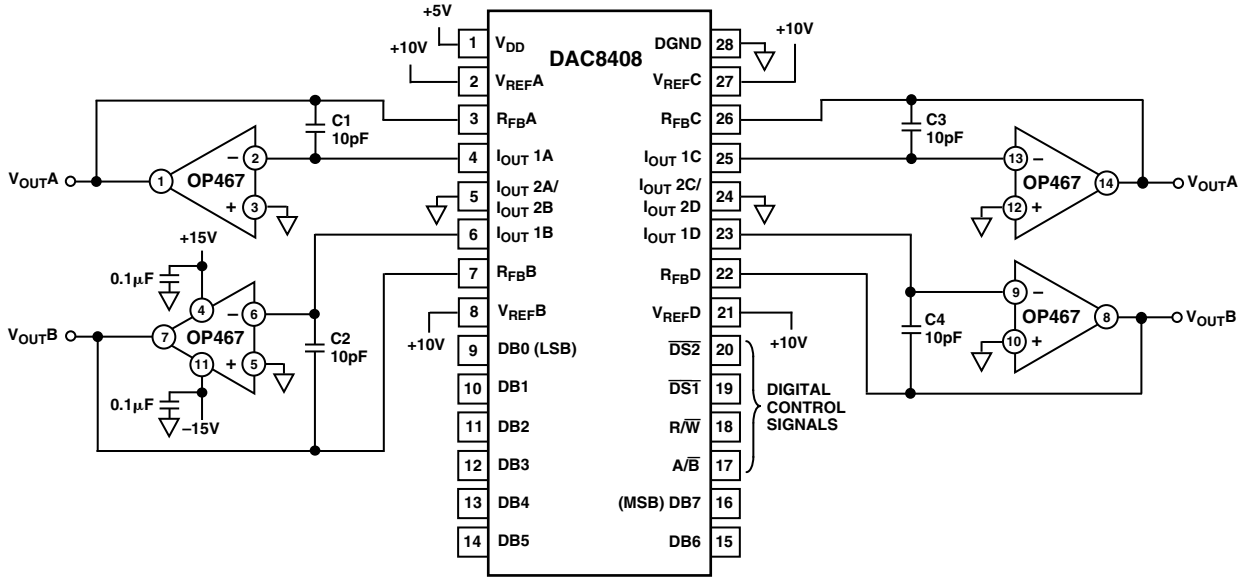

Figure 12. Quad DAC Unipolar Operation

## Fast I-To-V Converter

The fast slew rate and fast settling time of the OP467 are well suited to the fast buffers and I-to-V converters used in a variety of applications. The circuit in Figure 12 is a unipolar quad DAC consisting of only two ICs. The current output of the DAC8408 is converted to a voltage by the OP467 configured as an I-to-V converter. This circuit is capable of settling to 0.1% within 200 ns. Figures 13 and 14 show the full-scale settling time of the outputs. To obtain reliable circuit performance, keep the traces from the DAC's I<sub>OUT</sub> to the inverting inputs of the OP467 short to minimize parasitic capacitance.

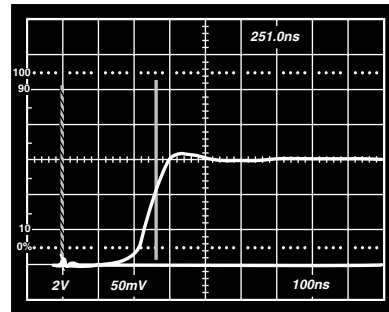

Figure 14. Voltage Output Settling Time

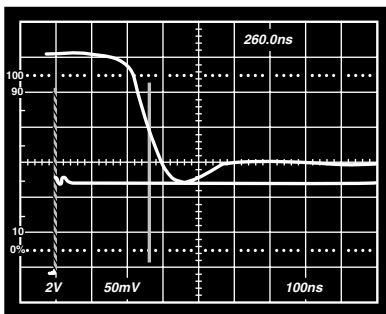

Figure 13. Voltage Output Settling Time

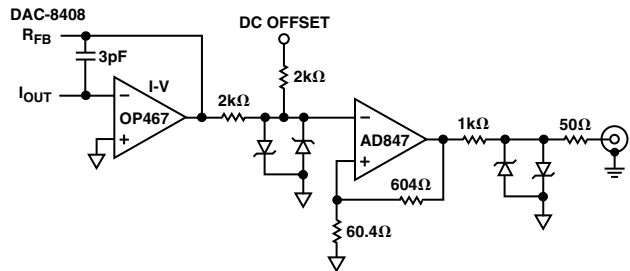
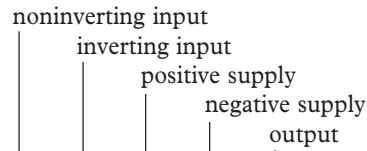

Figure 15. DAC V<sub>OUT</sub> Settling Time Circuit

**OP467 SPICE MACRO-MODEL**

\* Node assignments



```
*
.SUBCKT OP467 1 2 99 50 27
```

\* INPUT STAGE

```
*
I1      4  50  10E-3
CIN     1  2   1E-12
IOS     1  2   5E-9
Q1      5  2   8 QN
Q2      6  7   9 QN
R3      99  5  185 . 681
R4      99  6  185 . 681
R5      8  4   180 . 508
R6      9  4   180 . 508
EOS     7  1   POLY (1) (14,20) 50E-6 1
EREF    98  0  (20,0) 1
```

\* GAIN STAGE AND DOMINANT POLE AT 1.5 kHz

```
*
R7      10  98  3 . 714E6
C2      10  98  28 . 571E-12
G1      98  10  (5,6) 5 . 386E-3
V1      99  11  1 . 6
V2      12  50  1 . 6
D1      10  11  DX
D2      12  10  DX
RC      10  28  1 . 4E3
CC      28  27  12E-12
```

\*

\* COMMON-MODE STAGE WITH ZERO AT 1.26 kHz

\*

```
ECM     13  98  POLY (2) (1,20) (2,20) 0 0 . 5 0 . 5
R8      13  14  1E6
R9      14  98  25 . 119
C3      13  14  126 . 721E-12
```

\*

\* POLE AT 400E6

\*

```
R10     15  98  1E6
C4      15  98  0 . 398E-15
G2      98  15  (10,20) 1E-6
```

\*

\* OUTPUT STAGE

\*

```
ISY     99  50  -8 . 183E-3
RMP1    99  20  96 . 429E3
RMP2    20  50  96 . 429E3
RO1     99  26  200
RO2     26  50  200
L1      26  27  1E-7
GO1     26  99  (99,15) 5E-3
GO2     50  26  (15,50) 5E-3
G4      23  50  (15,26) 5E-3
G5      24  50  (26,15) 5E-3
V3      21  26  50
V4      26  22  50
D3      15  21  DX
D4      22  15  DX
D5      99  23  DX
D6      99  24  DX
D7      50  23  DY
D8      50  24  DY
```

\*

\* MODELS USED

\*

```
.MODEL QN NPN (BF=33.333E3)
.MODEL DX D
.MODEL DY D (BV=50)
.ENDS OP467
```

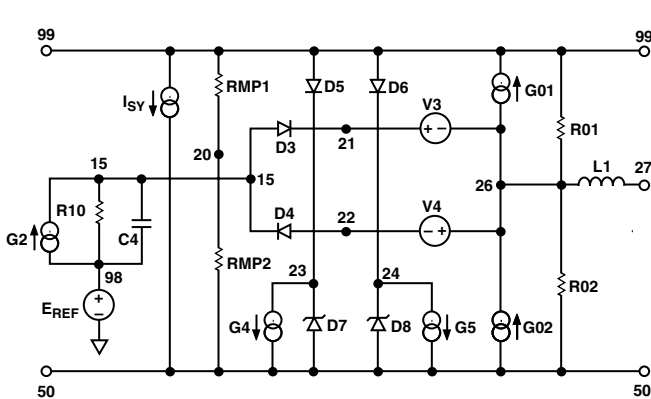

Figure 16. SPICE Macro-Model Output Stage

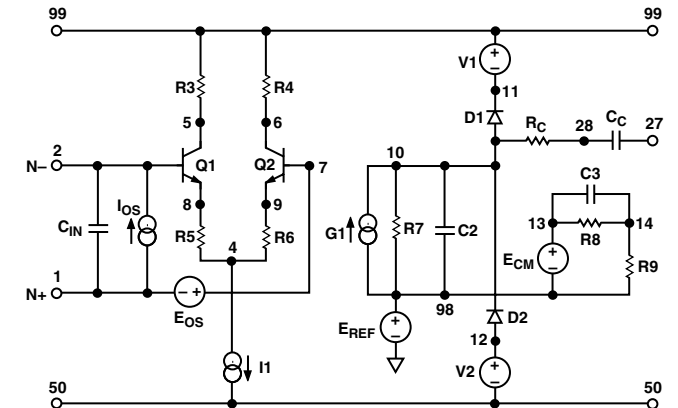

Figure 17. SPICE Macro-Model Input and Gain Stage

OUTLINE DIMENSIONS

14-Lead Plastic Dual In-Line Package [PDIP]

(N-14)  
P-Suffix

Dimensions shown in inches and (millimeters)

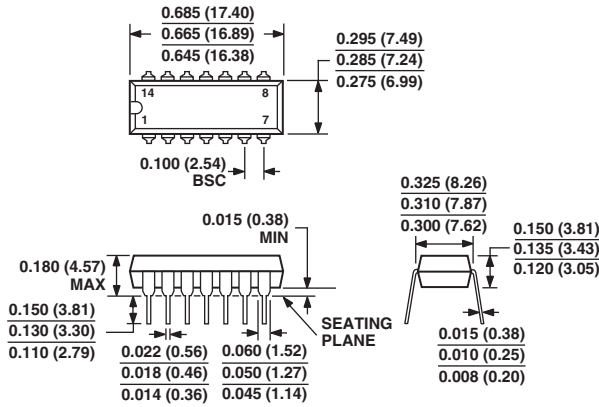

COMPLIANT TO JEDEC STANDARDS MO-095-AB  
CONTROLLING DIMENSIONS ARE IN INCHES; MILLIMETER DIMENSIONS (IN PARENTHESES) ARE ROUNDED-OFF INCH EQUIVALENTS FOR REFERENCE ONLY AND ARE NOT APPROPRIATE FOR USE IN DESIGN

14-Lead Ceramic Dual In-Line Package [CERDIP]

(Q-14)  
Y-Suffix

Dimensions shown in inches and (millimeters)

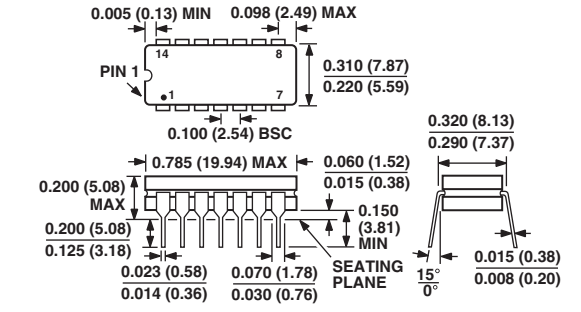

CONTROLLING DIMENSIONS ARE IN INCHES; MILLIMETERS DIMENSIONS (IN PARENTHESES) ARE ROUNDED-OFF INCH EQUIVALENTS FOR REFERENCE ONLY AND ARE NOT APPROPRIATE FOR USE IN DESIGN

16-Lead Standard Small Outline Package [SOIC]

Wide Body  
(RW-16)  
S-Suffix

Dimensions shown in millimeters and (inches)

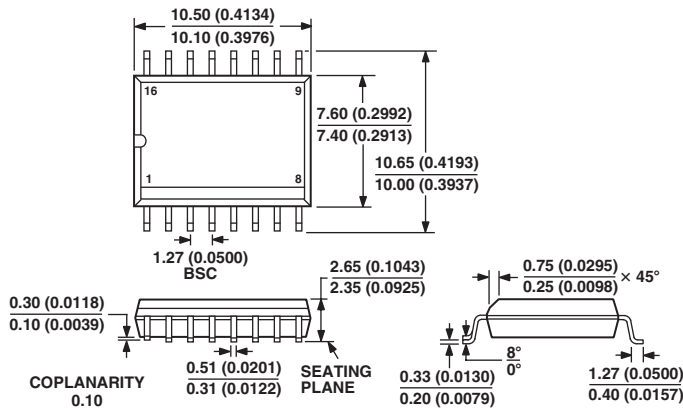

COMPLIANT TO JEDEC STANDARDS MS-013AA  
CONTROLLING DIMENSIONS ARE IN MILLIMETERS; INCH DIMENSIONS (IN PARENTHESES) ARE ROUNDED-OFF MILLIMETER EQUIVALENTS FOR REFERENCE ONLY AND ARE NOT APPROPRIATE FOR USE IN DESIGN

20-Terminal Ceramic Leadless Chip Carrier [LCC]

(E-20A)  
RC-Suffix

Dimensions shown in inches and (millimeters)

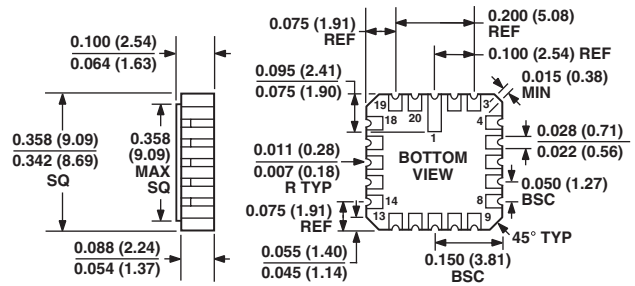

CONTROLLING DIMENSIONS ARE IN INCHES; MILLIMETERS DIMENSIONS (IN PARENTHESES) ARE ROUNDED-OFF INCH EQUIVALENTS FOR REFERENCE ONLY AND ARE NOT APPROPRIATE FOR USE IN DESIGN



# Revision History

<b>Location</b>	<b>Page</b>
<b>3/04—Data Sheet changed from REV. D to REV. E.</b>	
Changes to TPC 1 .....	5
Changes to ORDERING GUIDE .....	4
Updated OUTLINE DIMENSIONS .....	16
<b>4/01—Data Sheet changed from REV. C to REV. D.</b>	
Footnote added to POWER SUPPLY .....	2
Footnote added to MAX RATINGS .....	4
Edits to POWER SUPPLY CONSIDERATIONS section .....	11





