

THIS DRAWING IS UNPUBLISHED. RELEASED FOR PUBLICATION, 19  
 © COPYRIGHT 19 BY AMP INCORPORATED. ALL INTERNATIONAL RIGHTS RESERVED.

LOC	DIST	P	F	REVISIONS				
G	14			ZONE	LTR	DESCRIPTION	DATE	APPD
					M	REV / 0L20-0025-97	28JAN97	ME TM

<b>AMP</b> WIRE RANGE	<b>UL</b> Listed	<b>SR</b> LR7189 Certified
22-16 AWG SOLID OR STRANDED	22-16 AWG SOLID OR STRANDED	22-16 AWG SOLID OR STRANDED

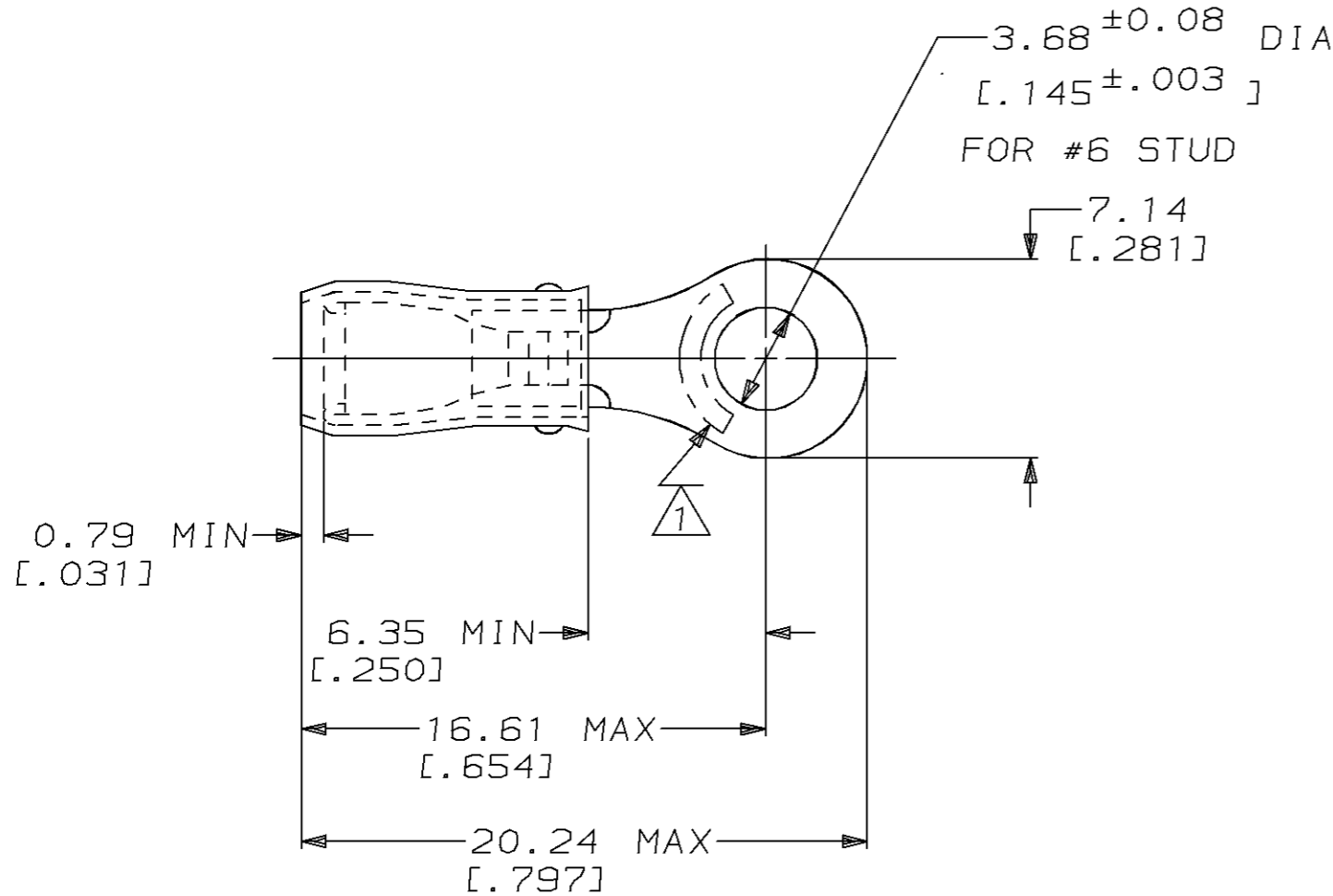

- 1 STAMP AMP 22-18\* APPROX AS SHOWN  
22-16 TERMINALS ARE STAMPED 22-18 IN  
ACCORDANCE WITH MILITARY SPEC MIL-T-7928  
COMMERCIAL WIRE RANGE IS 22-16
- 2 WIRE INSULATION DIA: .080 - .125
- 3 TONGUE MATERIAL THK: 0.79<sup>±0.05</sup> [.031<sup>±.002</sup>]

-	100	LOOSE PIECE BOX	8-36151-1
-	5000	ON TAPE, REEL	2-36151-2
-	-	LOOSE PIECE	36151
MILITARY P/N AND CLASS	QUANTITY	PACKAGE TYPE	PART NO
DO NOT SCALE PRINT. UNLESS SPECIFIED DIMENSIONS IN mm [INCHES] TOLERANCES ON: 2 PLC DEC ± 0.20 [.008] 3 PLC DEC ± - ANGLES ± -	DR 02/11/93 DK SCHRUM CHK 4/28/93 RE HERSEY APPD 4/28/93 ML ELLIS APPD 4/28/93 M BARNABA PRODUCT SPEC UL 486A	<b>AMP</b> AMP Incorporated Harrisburg, PA 17105-3608	
MATERIAL COPPER ASTM B-152 SLEEVE, RED NYLON	FINISH TIN PLATE PER MIL-T-10727	NAME TERMINAL, RING TONGUE, PIDG™, WIRE SIZE, 22-16 AWG	
	APPLICATION SPEC NOT AVAILABLE	SIZE B	CAGE CODE 00779
	WEIGHT -	DRAWING NO C-36151	SHEET 1 OF 1
		SCALE 4:1	

**AMP INCORPORATED  
CUSTOMER SERVICE SYSTEMS**

FOR ADDITIONAL PRODUCT INFORMATION OR COPIES OF DRAWINGS AND TECHNICAL DOCUMENTS	PRODUCT INFORMATION CENTER 1-800-522-6752
FOR APPLICATION TOOLING INFORMATION	TOOLING ASSISTANCE CENTER 1-800-722-1111
FOR ORDER ENTRY	1-800-526-5142

MAX RECOMMENDED OPERATING  
TEMPERATURE:  
105°C MAX

VOLTAGE RATING:  
300 V MAX

WIRE CROSS SECTIONAL AREA RANGE:  
0.26-1.65mm<sup>2</sup> [509-3,260] CIR MILS  
SOLID OR STRANDED

THIS DRAWING IS A CONTROLLED DOCUMENT FOR  
AMP INCORPORATED. IT IS SUBJECT TO CHANGE  
AND THE CONTROLLING ENGINEERING ORGANIZATION  
SHOULD BE CONTACTED FOR THE LATEST REVISION.