

THIS DRAWING IS UNPUBLISHED. RELEASED FOR PUBLICATION 19  
 © COPYRIGHT 19 BY AMP INCORPORATED, HARRISBURG, PA. ALL INTERNATIONAL RIGHTS RESERVED. AMP PRODUCTS MAY BE COVERED BY U.S. AND FOREIGN PATENTS AND/OR PATENTS PENDING.

211570-1 OBSOLETE  
 -2 1. AS SHOWN  
 2. WITHOUT CONTACTS AND TOOL.

REVISIONS					DATE	APPROVED
P	F	ZONE	LTR	DESCRIPTION	DATE	APPROVED
✓	✓		O	RELEASE	1/19/82	DF
✓	✓		A	ADDED -2 PER ECN K-089	3/14/83	TLB
✓	✓		B	OBS.-1 / ECN R-2554	3-30-87	Rg em

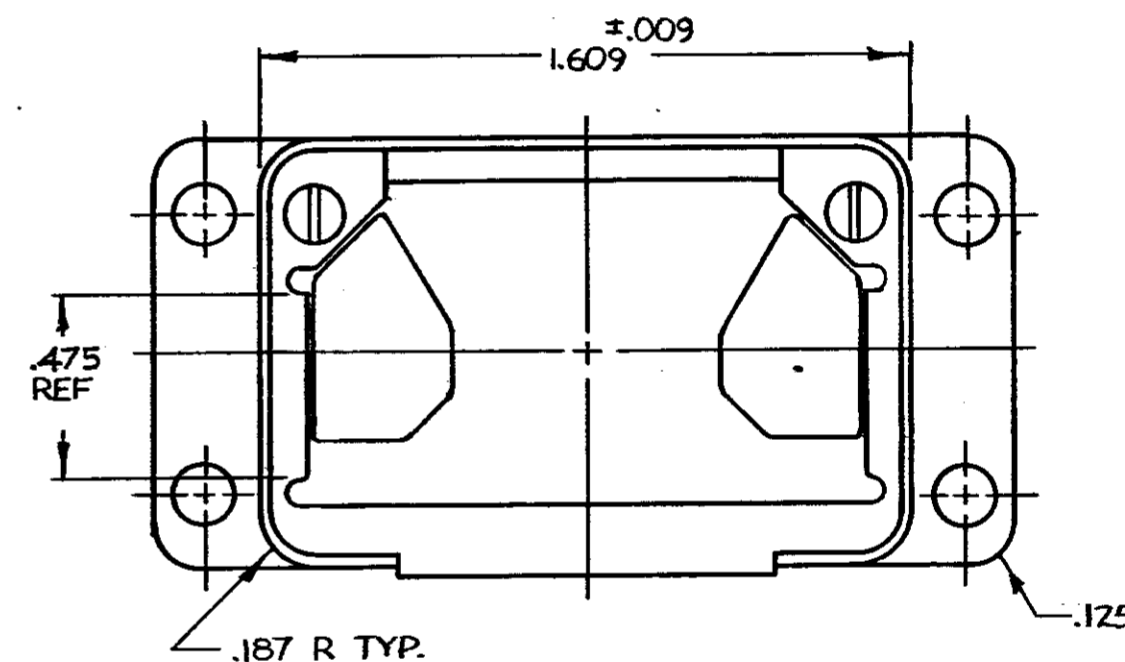
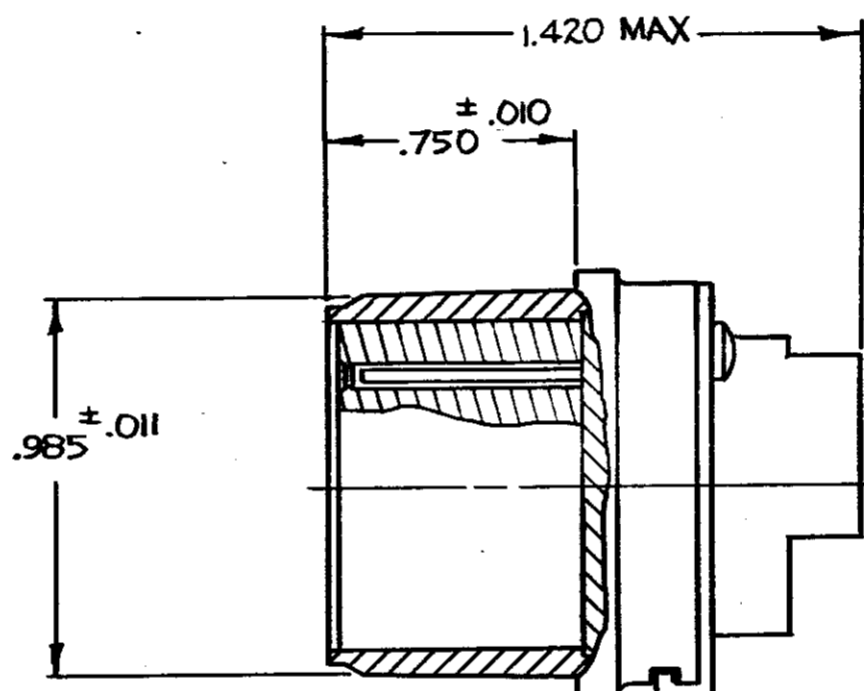
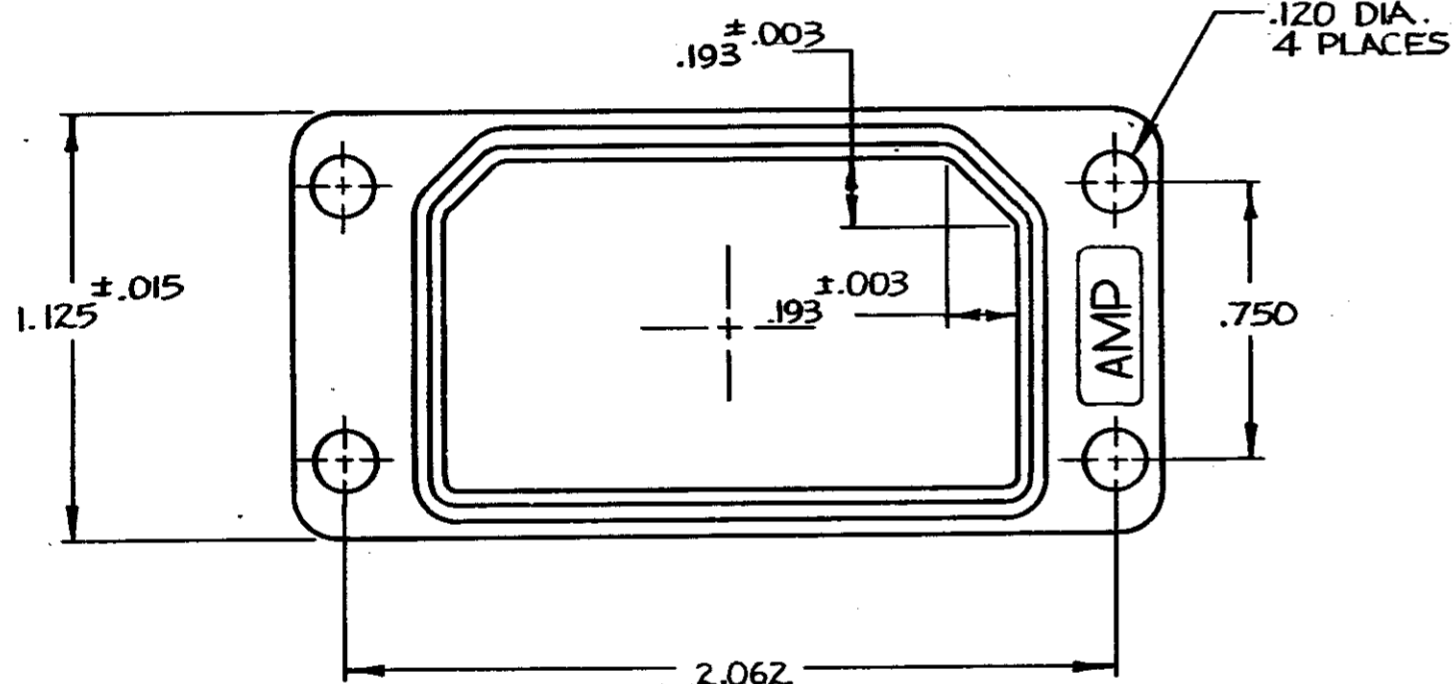
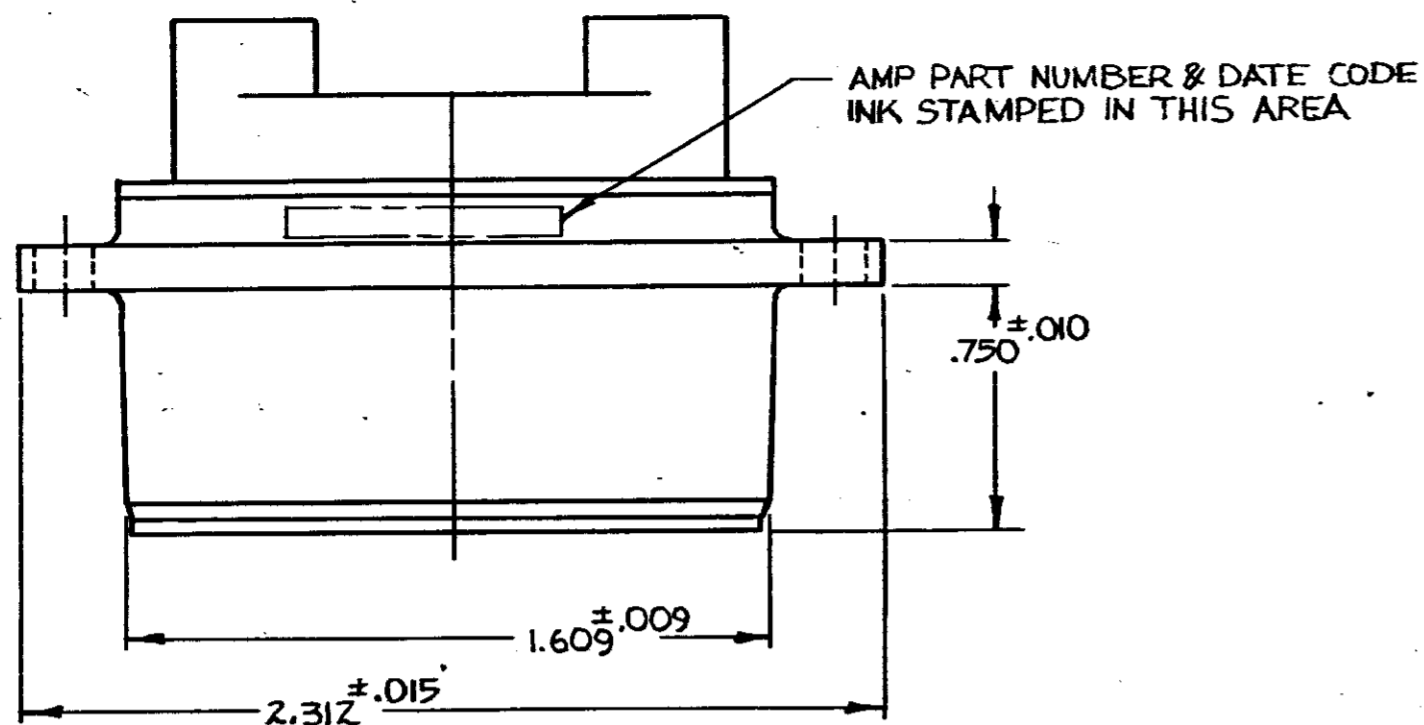

**MATERIAL & FINISH**

SHELL - DIE CAST ALUMINUM ALLOY PER QQ-A-591; CADMIUM PLATED PER QQ-P-416, TYPE I, CLASS 2  
 RETAINER PLATE - STEEL PER QQ-S-698; CADMIUM PLATED PER QQ-P-416 TYPE I, CLASS 2  
 SCREWS - STEEL PER QQ-S-698; CADMIUM PLATED PER QQ-P-416 TYPE I, CLASS 2  
 INSERTS - GLASS FILLED EPOXY PER MIL-M-24325  
 CONTACTS - COPPER ALLOY PER MIL-C-50; .000050 GOLD PLATED PER MIL-G-45204 OVER .000030 NICKEL PLATED PER QQ-N-290

⚠ CONTACTS ARE PACKAGED IN SEPARATE CONTAINER FOR SHIPMENT. COAX CONTACTS NOT INCLUDED.

- FOR MATING CONNECTOR ORDER RMAIP32C2S
- FOR ADDITIONAL INFORMATION SEE DWG 205102.
- THIS CONNECTOR MEETS SPEC 108 10,019

UNLESS OTHERWISE SPECIFIED DIMENSIONS ARE IN INCHES. TOLERANCES ON: DECIMALS ±.005 ANGLES ±		CONTRACT NO DR <i>Erdman</i> 11-18-82		AMP   AMP INCORPORATED Harrisburg, Pa. 17105	
MATERIAL SEE CALLOUT		CHK <i>[Signature]</i> 11-19-82		NAME PLUG, CONNECTOR, INSTALLATION RMAIP32C2S-00(200)	
FINISH SEE CALLOUT		APPD <i>[Signature]</i> 11-19-82 APPD <i>[Signature]</i> 11-19-82		SIZE C	FSCM NO 00779
		DSGN APPD		DRAWING NO 211570	
		OTHER APPD		SCALE #	SHEET 1 of 1