

**MACH210A-7/10/12****MACH210-12/15/20****MACH210AQ-12/15/20****High-Density EE CMOS Programmable Logic****DISTINCTIVE CHARACTERISTICS**

- 44 Pins
- 64 Macrocells
- 7.5 ns  $t_{PD}$  Commercial  
12 ns  $t_{PD}$  Industrial
- 133 MHz  $f_{CNT}$
- 38 Inputs; 210A Inputs have built-in pull-up resistors
- Peripheral Component Interconnect (PCI) compliant
- 32 Outputs
- 64 Flip-flops; 2 clock choices
- 4 "PAL22V16" blocks with buried macrocells
- Pin-compatible with MACH110, MACH111, MACH211, and MACH215

**GENERAL DESCRIPTION**

The MACH210 is a member of AMD's high-performance EE CMOS MACH 2 device family. This device has approximately six times the logic macrocell capability of the popular PAL22V10 without loss of speed.

The MACH210 consists of four PAL blocks interconnected by a programmable switch matrix. The four PAL blocks are essentially "PAL22V16" structures complete with product-term arrays and programmable macrocells, including additional buried macrocells. The switch matrix connects the PAL blocks to each other and to all input pins, providing a high degree of connectivity between the fully-connected PAL blocks. This allows designs to be placed and routed efficiently.

The MACH210 has two kinds of macrocell: output and buried. The MACH210 output macrocell provides regis-

tered, latched, or combinatorial outputs with programmable polarity. If a registered configuration is chosen, the register can be configured as D-type or T-type to help reduce the number of product terms. The register type decision can be made by the designer or by the software. All output macrocells can be connected to an I/O cell. If a buried macrocell is desired, the internal feedback path from the macrocell can be used, which frees up the I/O pin for use as an input.

The MACH210 has dedicated buried macrocells which, in addition to the capabilities of the output macrocell, also provide input registers or latches for use in synchronizing signals and reducing setup time requirements.

BLOCK DIAGRAM

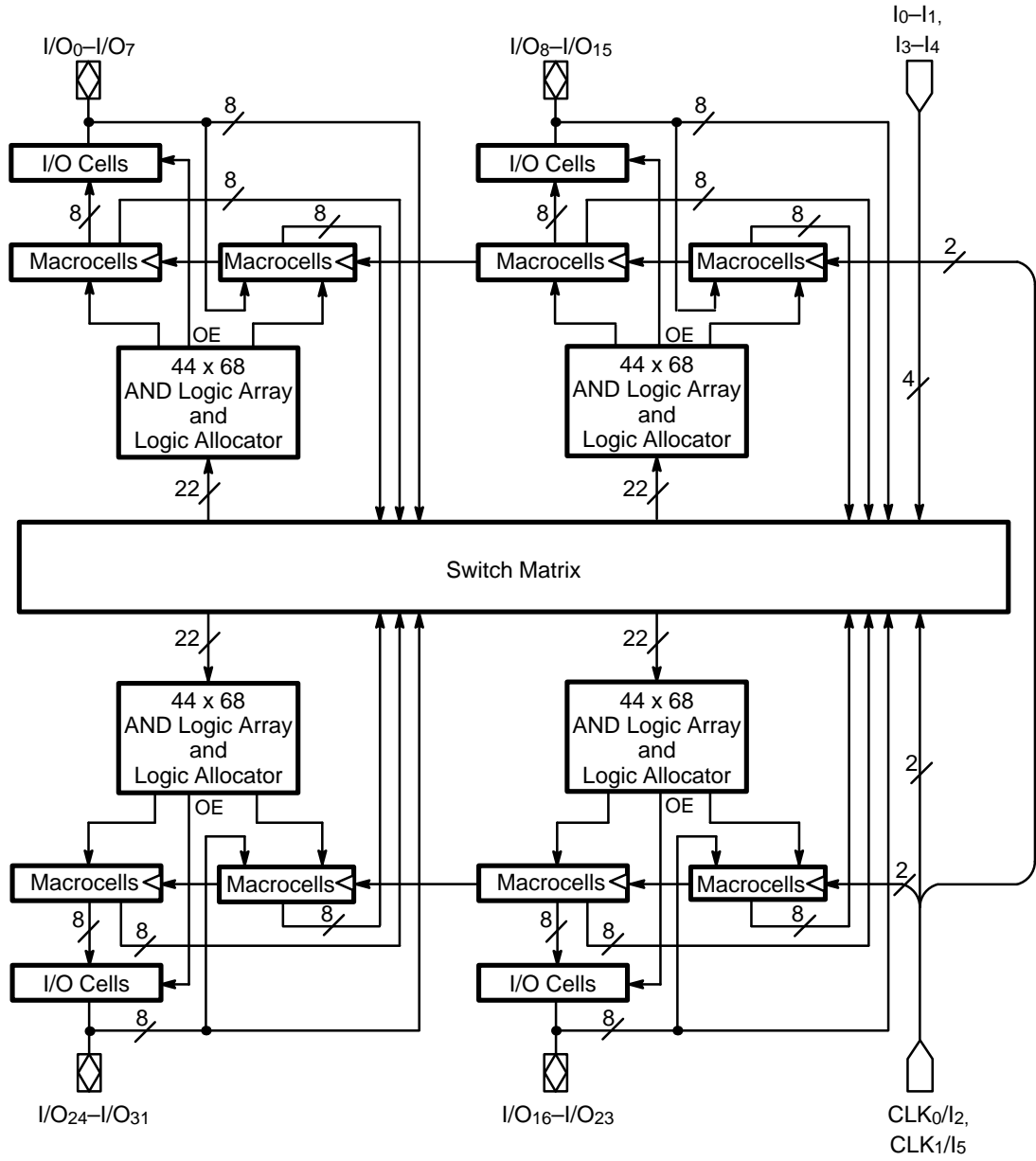

14128I-1

**CONNECTION DIAGRAM**  
**Top View**

**PLCC**

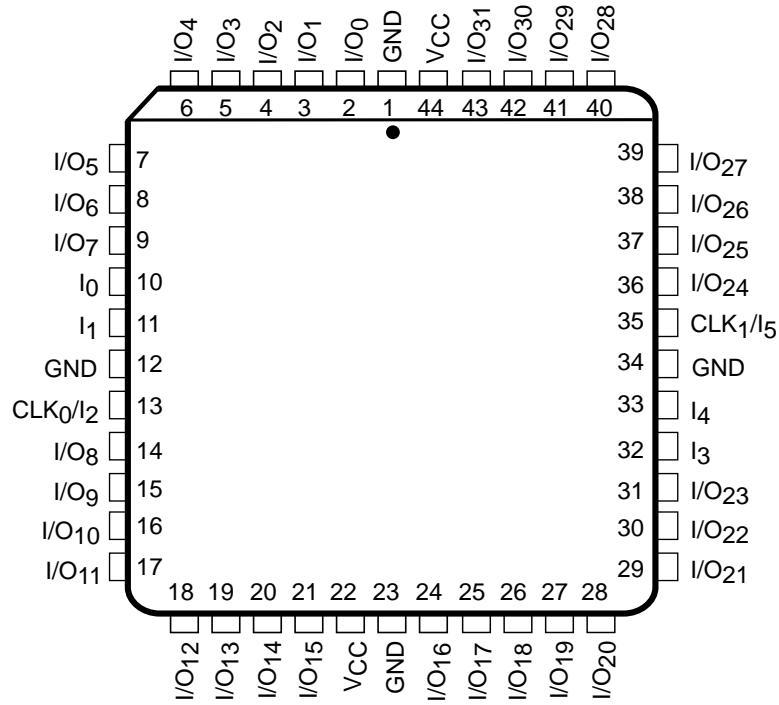

14128I-2

**Note:**  
**Pin-compatible with MACH110, MACH111, MACH211, and MACH215.**

# CONNECTION DIAGRAM

## Top View

### TQFP

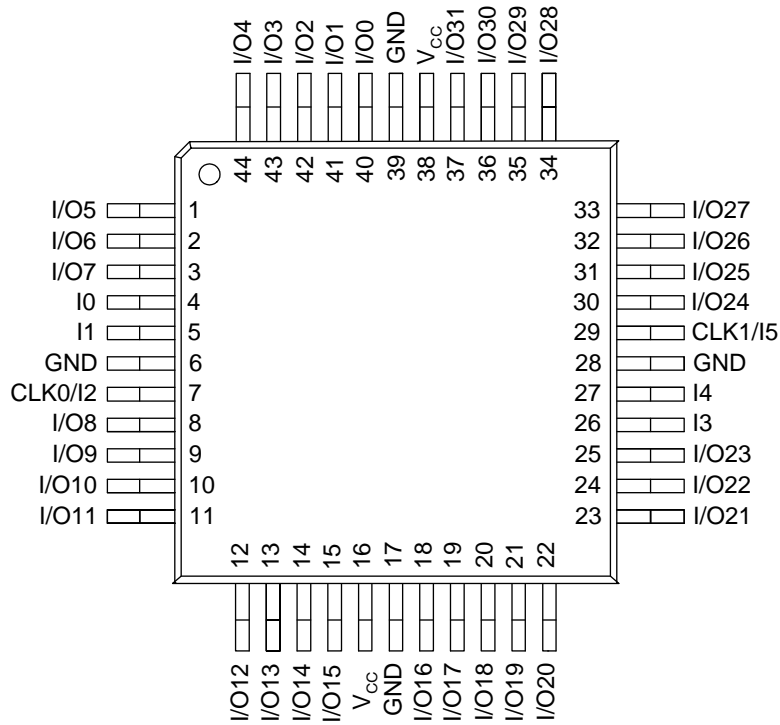

**Note:**  
Pin-compatible with MACH111 and MACH211.

141281-3

## PIN DESIGNATIONS

- CLK/I = Clock or Input
- GND = Ground
- I = Input
- I/O = Input/Output
- Vcc = Supply Voltage

## ORDERING INFORMATION

### Commercial Products

AMD programmable logic products for commercial applications are available with several ordering options. The order number (Valid Combination) is formed by a combination of:

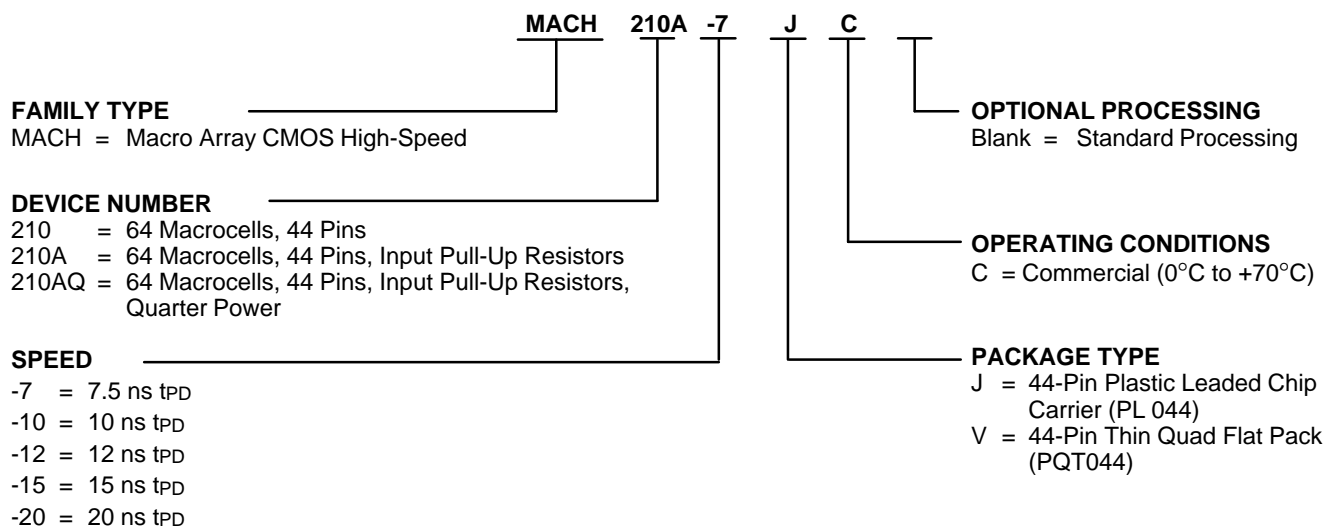

Valid Combinations	
MACH210A-7	JC, VC
MACH210A-10	
MACH210A-12	
MACH210-12	JC
MACH210-15	
MACH210-20	
MACH210AQ-12	
MACH210AQ-15	
MACH210AQ-20	

#### Valid Combinations

The Valid Combinations table lists configurations planned to be supported in volume for this device. Consult the local AMD sales office to confirm availability of specific valid combinations or to check on newly released combinations.

## ORDERING INFORMATION

### Industrial Products

AMD programmable logic products for industrial applications are available with several ordering options. The order number (Valid Combination) is formed by a combination of:

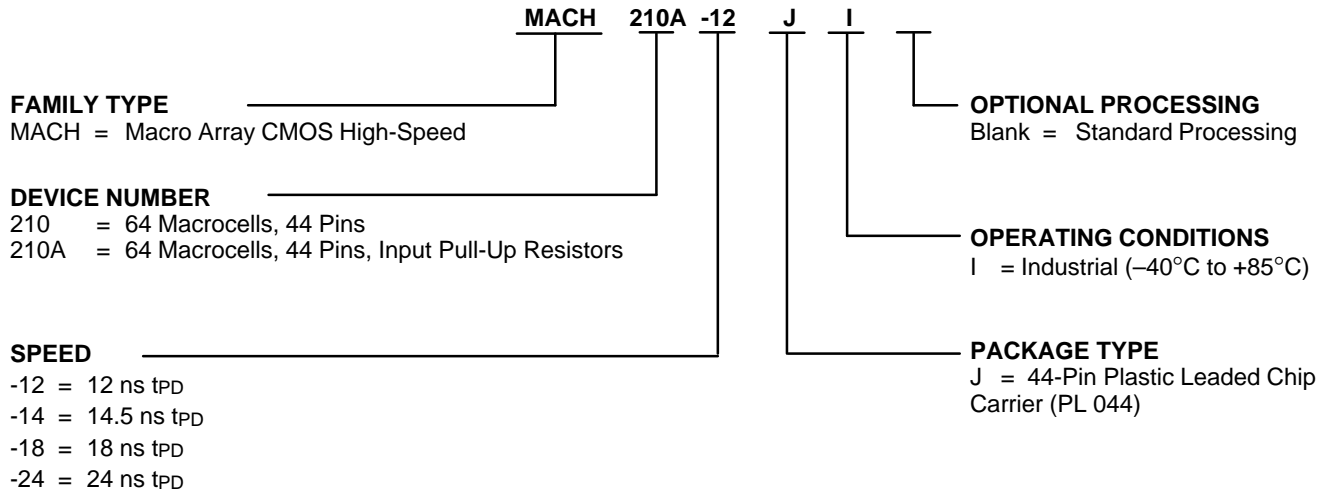

Valid Combinations	
MACH210A-12	JI
MACH210A-14	
MACH210-14	
MACH210-18	
MACH210-24	

#### Valid Combinations

The Valid Combinations table lists configurations planned to be supported in volume for this device. Consult the local AMD sales office to confirm availability of specific valid combinations or to check on newly released combinations.

## FUNCTIONAL DESCRIPTION

The MACH210 consists of four PAL blocks connected by a switch matrix. There are 32 I/O pins and 4 dedicated input pins feeding the switch matrix. These signals are distributed to the four PAL blocks for efficient design implementation. There are two clock pins that can also be used as dedicated inputs.

The MACH210A inputs and I/O pins have built-in pull-up resistors. While it is always a good design practice to tie unused pins high, the 210A pull-up resistors provide design security and stability in the event that unused pins are left disconnected.

### The PAL Blocks

Each PAL block in the MACH210 (Figure 1) contains a 64-product-term logic array, a logic allocator, 8 output macrocells, 8 buried macrocells, and 8 I/O cells. The switch matrix feeds each PAL block with 22 inputs. This makes the PAL block look effectively like an independent “PAL22V16” with 8 buried macrocells.

In addition to the logic product terms, two output enable product terms, an asynchronous reset product term, and an asynchronous preset product term are provided. One of the two output enable product terms can be chosen within each I/O cell in the PAL block. All flip-flops within the PAL block are initialized together.

### The Switch Matrix

The MACH210 switch matrix is fed by the inputs and feedback signals from the PAL blocks. Each PAL block provides 16 internal feedback signals and 8 I/O feedback signals. The switch matrix distributes these signals back to the PAL blocks in an efficient manner that also provides for high performance. The design software automatically configures the switch matrix when fitting a design into the device.

### The Product-term Array

The MACH210 product-term array consists of 64 product terms for logic use, and 4 special-purpose product terms. Two of the special-purpose product terms provide programmable output enable; one provides asynchronous reset, and one provides asynchronous preset.

### The Logic Allocator

The logic allocator in the MACH210 takes the 64 logic product terms and allocates them to the 16 macrocells as needed. Each macrocell can be driven by up to 16 product terms. The design software automatically configures the logic allocator when fitting the design into the device.

Table 1 illustrates which product term clusters are available to each macrocell within a PAL block. Refer to Figure 1 for cluster and macrocell numbers.

**Table 1. Logic Allocation**

Macrocell		Available Clusters
Output	Buried	
M <sub>0</sub>	M <sub>1</sub>	C <sub>0</sub> , C <sub>1</sub> , C <sub>2</sub> C <sub>0</sub> , C <sub>1</sub> , C <sub>2</sub> , C <sub>3</sub>
M <sub>2</sub>	M <sub>3</sub>	C <sub>1</sub> , C <sub>2</sub> , C <sub>3</sub> , C <sub>4</sub> C <sub>2</sub> , C <sub>3</sub> , C <sub>4</sub> , C <sub>5</sub>
M <sub>4</sub>	M <sub>5</sub>	C <sub>3</sub> , C <sub>4</sub> , C <sub>5</sub> , C <sub>6</sub> C <sub>4</sub> , C <sub>5</sub> , C <sub>6</sub> , C <sub>7</sub>
M <sub>6</sub>	M <sub>7</sub>	C <sub>5</sub> , C <sub>6</sub> , C <sub>7</sub> , C <sub>8</sub> C <sub>6</sub> , C <sub>7</sub> , C <sub>8</sub> , C <sub>9</sub>
M <sub>8</sub>	M <sub>9</sub>	C <sub>7</sub> , C <sub>8</sub> , C <sub>9</sub> , C <sub>10</sub> C <sub>8</sub> , C <sub>9</sub> , C <sub>10</sub> , C <sub>11</sub>
M <sub>10</sub>	M <sub>11</sub>	C <sub>9</sub> , C <sub>10</sub> , C <sub>11</sub> , C <sub>12</sub> C <sub>10</sub> , C <sub>11</sub> , C <sub>12</sub> , C <sub>13</sub>
M <sub>12</sub>	M <sub>13</sub>	C <sub>11</sub> , C <sub>12</sub> , C <sub>13</sub> , C <sub>14</sub> C <sub>12</sub> , C <sub>13</sub> , C <sub>14</sub> , C <sub>15</sub>
M <sub>14</sub>	M <sub>15</sub>	C <sub>13</sub> , C <sub>14</sub> , C <sub>15</sub> C <sub>14</sub> , C <sub>15</sub>

### The Macrocell

The MACH210 has two types of macrocell: output and buried. The output macrocells can be configured as either registered, latched, or combinatorial, with programmable polarity. The macrocell provides internal feedback whether configured with or without the flip-flop. The registers can be configured as D-type or T-type, allowing for product-term optimization.

The flip-flops can individually select one of two clock/gate pins, which are also available as data inputs. The registers are clocked on the LOW-to-HIGH transition of the clock signal. The latch holds its data when the gate input is HIGH, and is transparent when the gate input is LOW. The flip-flops can also be asynchronously initialized with the common asynchronous reset and preset product terms.

The buried macrocells are the same as the output macrocells if they are used for generating logic. In that case, the only thing that distinguishes them from the output macrocells is the fact that there is no I/O cell connection, and the signal is only used internally. The buried macrocell can also be configured as an input register or latch.

## The I/O Cell

The I/O cell in the MACH210 consists of a three-state output buffer. The three-state buffer can be configured in one of three ways: always enabled, always disabled, or controlled by a product term. If product term control is chosen, one of two product terms may be used to provide the control. The two product terms that are available are common to all I/O cells in a PAL block.

These choices make it possible to use the macrocell as an output, an input, a bidirectional pin, or a three-state output for use in driving a bus.

## PCI Compliance

The MACH210A-7/10 is fully compliant with the *PCI Local Bus Specification* published by the PCI Special Interest Group. The MACH210A-7/10's predictable timing ensures compliance with the PCI AC specifications independent of the design. On the other hand, in CPLD and FPGA architectures without predictable timing, PCI compliance is dependent upon routing and product term distribution.



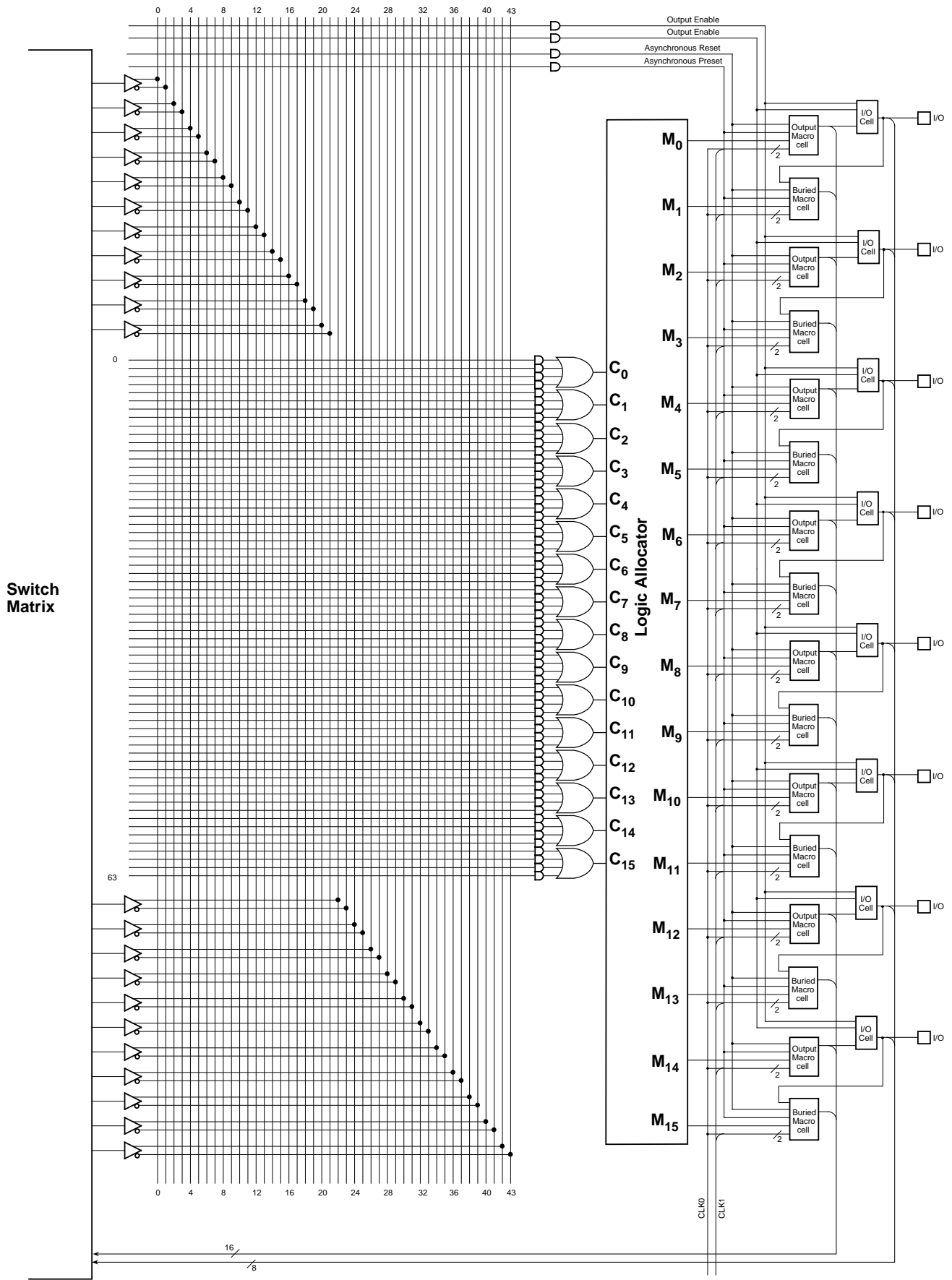

141281-4

Figure 1. MACH210 PAL Block

## ABSOLUTE MAXIMUM RATINGS

Storage Temperature	.....	-65°C to +150°C
Ambient Temperature with Power Applied	.....	-55°C to +125°C
Supply Voltage with Respect to Ground	.....	-0.5 V to +7.0 V
DC Input Voltage	.....	-0.5 V to $V_{CC} + 0.5$ V
DC Output or I/O Pin Voltage	.....	-0.5 V to $V_{CC} + 0.5$ V
Static Discharge Voltage	.....	2001 V
Latchup Current ( $T_A = 0^\circ\text{C}$ to $+70^\circ\text{C}$ )	.....	200 mA

Stresses above those listed under Absolute Maximum Ratings may cause permanent device failure. Functionality at or above these limits is not implied. Exposure to Absolute Maximum Ratings for extended periods may affect device reliability. Programming conditions may differ.

## OPERATING RANGES

### Commercial (C) Devices

Temperature ( $T_A$ ) Operating in Free Air	.....	0°C to +70°C
Supply Voltage ( $V_{CC}$ ) with Respect to Ground	.....	+4.75 V to +5.25 V

Operating ranges define those limits between which the functionality of the device is guaranteed.

## DC CHARACTERISTICS over COMMERCIAL operating ranges unless otherwise specified

Parameter Symbol	Parameter Description	Test Conditions	Min	Typ	Max	Unit
$V_{OH}$	Output HIGH Voltage	$I_{OH} = -3.2$ mA, $V_{CC} = \text{Min}$ $V_{IN} = V_{IH}$ or $V_{IL}$	2.4			V
$V_{OL}$	Output LOW Voltage	$I_{OL} = 16$ mA, $V_{CC} = \text{Min}$ $V_{IN} = V_{IH}$ or $V_{IL}$			0.5	V
$V_{IH}$	Input HIGH Voltage	Guaranteed Input Logical HIGH Voltage for all Inputs (Note 1)	2.0			V
$V_{IL}$	Input LOW Voltage	Guaranteed Input Logical LOW Voltage for all Inputs (Note 1)			0.8	V
$I_{IH}$	Input HIGH Leakage Current	$V_{IN} = 5.25$ V, $V_{CC} = \text{Max}$ (Note 2)			10	$\mu\text{A}$
$I_{IL}$	Input LOW Leakage Current	$V_{IN} = 0$ V, $V_{CC} = \text{Max}$ (Note 2)			-100	$\mu\text{A}$
$I_{OZH}$	Off-State Output Leakage Current HIGH	$V_{OUT} = 5.25$ V, $V_{CC} = \text{Max}$ $V_{IN} = V_{IH}$ or $V_{IL}$ (Note 2)			10	$\mu\text{A}$
$I_{OZL}$	Off-State Output Leakage Current LOW	$V_{OUT} = 0$ V, $V_{CC} = \text{Max}$ $V_{IN} = V_{IH}$ or $V_{IL}$ (Note 2)			-100	$\mu\text{A}$
$I_{SC}$	Output Short-Circuit Current	$V_{OUT} = 0.5$ V, $V_{CC} = \text{Max}$ (Note 3)	-30		-160	mA
$I_{CC}$	Supply Current	$V_{IN} = 0$ V, Outputs Open ( $I_{OUT} = 0$ mA) $V_{CC} = 5.0$ V, $f = 25$ MHz, $T_A = 25^\circ\text{C}$ (Note 4)		130		mA

### Notes:

1. These are absolute values with respect to device ground and all overshoots due to system or tester noise are included.
2. I/O pin leakage is the worst case of  $I_{IL}$  and  $I_{OZL}$  (or  $I_{IH}$  and  $I_{OZH}$ ).
3. Not more than one output should be shorted at a time and duration of the short-circuit should not exceed one second.  $V_{OUT} = 0.5$  V has been chosen to avoid test problems caused by tester ground degradation.
4. This parameter is measured with a 16-bit up/down counter pattern. This pattern is programmed in each PAL block and capable of being loaded, enabled, and reset.

## CAPACITANCE (Note 1)

Parameter Symbol	Parameter Description	Test Conditions		Typ	Unit
C <sub>IN</sub>	Input Capacitance	V <sub>IN</sub> = 2.0 V	V <sub>CC</sub> = 5.0 V, T <sub>A</sub> = 25°C, f = 1 MHz	6	pF
C <sub>OUT</sub>	Output Capacitance	V <sub>OUT</sub> = 2.0 V		8	pF

## SWITCHING CHARACTERISTICS over COMMERCIAL operating ranges

Parameter Symbol	Parameter Description		-7		Unit
			Min	Max	
t <sub>PD</sub>	Input, I/O, or Feedback to Combinatorial Output			7.5	ns
t <sub>S</sub>	Setup Time from Input, I/O or Feedback to Clock	D-Type	5.5		ns
		T-Type	6.5		ns
t <sub>H</sub>	Register Data Hold Time		0		ns
t <sub>CO</sub>	Clock to Output			5	ns
t <sub>WL</sub>	Clock Width	LOW	3		ns
t <sub>WH</sub>		HIGH	3		ns
f <sub>MAX</sub>	Maximum Frequency	External Feedback	D-Type	100	MHz
			T-Type	91	MHz
		Internal Feedback (f <sub>CNT</sub> )	D-Type	133	MHz
			T-Type	125	MHz
No Feedback			166.7		MHz
t <sub>SL</sub>	Setup Time from Input, I/O, or Feedback to Gate		5.5		ns
t <sub>HL</sub>	Latch Data Hold Time		0		ns
t <sub>GO</sub>	Gate to Output			6	ns
t <sub>GWL</sub>	Gate Width LOW		3		ns
t <sub>PDL</sub>	Input, I/O, or Feedback to Output Through Transparent Input or Output Latch			9.5	ns
t <sub>SIR</sub>	Input Register Setup Time		2		ns
t <sub>HIR</sub>	Input Register Hold Time		2		ns
t <sub>ICO</sub>	Input Register Clock to Combinatorial Output			11	ns
t <sub>ICS</sub>	Input Register Clock to Output Register Setup	D-Type	9		ns
		T-Type	10		ns
t <sub>WICL</sub>	Input Register Clock Width	LOW	3		ns
t <sub>WICH</sub>		HIGH	3		ns
f <sub>MAXIR</sub>	Maximum Input Register Frequency		166.7		MHz
t <sub>SIL</sub>	Input Latch Setup Time		2		ns
t <sub>HIL</sub>	Input Latch Hold Time		2		ns
t <sub>I<sub>GO</sub></sub>	Input Latch Gate to Combinatorial Output			12	ns
t <sub>I<sub>GOL</sub></sub>	Input Latch Gate to Output Through Transparent Output Latch			14	ns
t <sub>SLL</sub>	Setup Time from Input, I/O, or Feedback Through Transparent Input Latch to Output Latch Gate		7.5		ns

**SWITCHING CHARACTERISTICS over COMMERCIAL operating ranges (continued)**

Parameter Symbol	Parameter Description	-7		Unit
		Min	Max	
tIGS	Input Latch Gate to Output Latch Setup	10		ns
tWIGL	Input Latch Gate Width LOW	3		ns
tPDLL	Input, I/O, or Feedback to Output Through Transparent Input and Output Latches		11.5	ns
tAR	Asynchronous Reset to Registered or Latched Output		12	ns
tARW	Asynchronous Reset Width	8		ns
tARR	Asynchronous Reset Recovery Time	8		ns
tAP	Asynchronous Preset to Registered or Latched Output		12	ns
tAPW	Asynchronous Preset Width	8		ns
tAPR	Asynchronous Preset Recovery Time	8		ns
tEA	Input, I/O, or Feedback to Output Enable		7.5	ns
tER	Input, I/O, or Feedback to Output Disable		7.5	ns

**Note:**

1. These parameters are not 100% tested, but are evaluated at initial characterization and at any time the design is modified where capacitance may be affected.

## ABSOLUTE MAXIMUM RATINGS

Storage Temperature	−65°C to +150°C
Ambient Temperature with Power Applied	−55°C to +125°C
Supply Voltage with Respect to Ground	−0.5 V to +7.0 V
DC Input Voltage	−0.5 V to $V_{CC} + 0.5$ V
DC Output or I/O Pin Voltage	−0.5 V to $V_{CC} + 0.5$ V
Static Discharge Voltage	2001 V
Latchup Current ( $T_A = 0^\circ\text{C}$ to $+70^\circ\text{C}$ )	200 mA

Stresses above those listed under Absolute Maximum Ratings may cause permanent device failure. Functionality at or above these limits is not implied. Exposure to Absolute Maximum Ratings for extended periods may affect device reliability. Programming conditions may differ.

## OPERATING RANGES

### Commercial (C) Devices

Temperature ( $T_A$ ) Operating in Free Air	0°C to +70°C
Supply Voltage ( $V_{CC}$ ) with Respect to Ground	+4.75 V to +5.25 V

Operating ranges define those limits between which the functionality of the device is guaranteed.

## DC CHARACTERISTICS over COMMERCIAL operating ranges unless otherwise specified

Parameter Symbol	Parameter Description	Test Conditions	Min	Typ	Max	Unit
$V_{OH}$	Output HIGH Voltage	$I_{OH} = -3.2$ mA, $V_{CC} = \text{Min}$ $V_{IN} = V_{IH}$ or $V_{IL}$	2.4			V
$V_{OL}$	Output LOW Voltage	$I_{OL} = 16$ mA, $V_{CC} = \text{Min}$ $V_{IN} = V_{IH}$ or $V_{IL}$			0.5	V
$V_{IH}$	Input HIGH Voltage	Guaranteed Input Logical HIGH Voltage for all Inputs (Note 1)	2.0			V
$V_{IL}$	Input LOW Voltage	Guaranteed Input Logical LOW Voltage for all Inputs (Note 1)			0.8	V
$I_{IH}$	Input HIGH Leakage Current	$V_{IN} = 5.25$ V, $V_{CC} = \text{Max}$ (Note 2)			10	$\mu\text{A}$
$I_{IL}$	Input LOW Leakage Current	$V_{IN} = 0$ V, $V_{CC} = \text{Max}$ (Note 2)			−100	$\mu\text{A}$
$I_{OZH}$	Off-State Output Leakage Current HIGH	$V_{OUT} = 5.25$ V, $V_{CC} = \text{Max}$ $V_{IN} = V_{IH}$ or $V_{IL}$ (Note 2)			10	$\mu\text{A}$
$I_{OZL}$	Off-State Output Leakage Current LOW	$V_{OUT} = 0$ V, $V_{CC} = \text{Max}$ $V_{IN} = V_{IH}$ or $V_{IL}$ (Note 2)			−100	$\mu\text{A}$
$I_{SC}$	Output Short-Circuit Current	$V_{OUT} = 0.5$ V, $V_{CC} = \text{Max}$ (Note 3)	−30		−160	mA
$I_{CC}$	Supply Current (Typical)	$V_{CC} = 5$ V, $T_A = 25^\circ\text{C}$ , $f = 25$ MHz (Note 4)		135		mA

### Notes:

- These are absolute values with respect to device ground and all overshoots due to system or tester noise are included.
- I/O pin leakage is the worst case of  $I_{IL}$  and  $I_{OZL}$  (or  $I_{IH}$  and  $I_{OZH}$ ).
- Not more than one output should be shorted at a time and duration of the short-circuit should not exceed one second.  
 $V_{OUT} = 0.5$  V has been chosen to avoid test problems caused by tester ground degradation.
- Measured with a 16-bit up/down counter pattern. This pattern is programmed in each PAL block and is capable of being loaded, enabled, and reset.

## CAPACITANCE (Note 1)

Parameter Symbol	Parameter Description	Test Conditions		Typ	Unit
C <sub>IN</sub>	Input Capacitance	V <sub>IN</sub> = 2.0 V	V <sub>CC</sub> = 5.0 V, T <sub>A</sub> = 25°C, f = 1 MHz	6	pF
C <sub>OUT</sub>	Output Capacitance	V <sub>OUT</sub> = 2.0 V		8	pF

## SWITCHING CHARACTERISTICS over COMMERCIAL operating ranges (Note 2)

Parameter Symbol	Parameter Description		-10		-12		Unit
			Min	Max	Min	Max	
t <sub>PD</sub>	Input, I/O, or Feedback to Combinatorial Output (Note 3)			10		12	ns
t <sub>S</sub>	Setup Time from Input, I/O, or Feedback to Clock		D-Type	6.5		7	ns
			T-Type	7.5		8	ns
t <sub>H</sub>	Register Data Hold Time		0		0		ns
t <sub>CO</sub>	Clock to Output (Note 3)			6		8	ns
t <sub>WL</sub>	Clock Width		LOW	5		6	ns
t <sub>WH</sub>			HIGH	5		6	ns
f <sub>MAX</sub>	Maximum Frequency (Note 1)	External Feedback	1/(t <sub>S</sub> + t <sub>CO</sub> )	D-Type	80	66.7	MHz
			T-Type	74	62.5	MHz	
		Internal Feedback (f <sub>CNT</sub> )	D-Type	100	83.3	MHz	
			T-Type	91	76.9	MHz	
No Feedback	1/(t <sub>S</sub> + t <sub>H</sub> )	100		83.3	MHz		
t <sub>SL</sub>	Setup Time from Input, I/O, or Feedback to Gate		6.5		7		ns
t <sub>HL</sub>	Latch Data Hold Time		0		0		ns
t <sub>GO</sub>	Gate to Output (Note 3)			7		10	ns
t <sub>GWL</sub>	Gate Width LOW		5		6		ns
t <sub>PDL</sub>	Input, I/O, or Feedback to Output Through Transparent Input or Output Latch			12		14	ns
t <sub>SIR</sub>	Input Register Setup Time		2		2		ns
t <sub>HIR</sub>	Input Register Hold Time		2		2		ns
t <sub>ICO</sub>	Input Register Clock to Combinatorial Output			13		15	ns
t <sub>ICS</sub>	Input Register Clock to Output Register Setup		D-Type	10		12	ns
			T-Type	11		13	ns
t <sub>WICL</sub>	Input Register Clock Width		LOW	5		6	ns
t <sub>WICH</sub>			HIGH	5		6	ns
f <sub>MAXIR</sub>	Maximum Input Register Frequency	1/(t <sub>WICL</sub> + t <sub>WICH</sub> )	100		83.3		MHz
t <sub>SIL</sub>	Input Latch Setup Time		2		2		ns
t <sub>HIL</sub>	Input Latch Hold Time		2		2		ns
t <sub>IGO</sub>	Input Latch Gate to Combinatorial Output			14		17	ns
t <sub>IGOL</sub>	Input Latch Gate to Output Through Transparent Output Latch			16		19	ns
t <sub>SLL</sub>	Setup Time from Input, I/O, or Feedback Through Transparent Input Latch to Output Latch Gate		8.5		9		ns
t <sub>IGS</sub>	Input Latch Gate to Output Latch Setup		11		13		ns

**SWITCHING CHARACTERISTICS over COMMERCIAL operating ranges (Note 2)  
(continued)**

Parameter Symbol	Parameter Description	-10		-12		Unit
		Min	Max	Min	Max	
t <sub>WIGL</sub>	Input Latch Gate Width LOW	5		6		ns
t <sub>PDLL</sub>	Input, I/O, or Feedback to Output Through Transparent Input and Output Latches		14		16	ns
t <sub>AR</sub>	Asynchronous Reset to Registered or Latched Output		25		16	ns
t <sub>ARW</sub>	Asynchronous Reset Width (Note 1)	10		12		ns
t <sub>ARR</sub>	Asynchronous Reset Recovery Time (Note 1)	10		8		ns
t <sub>AP</sub>	Asynchronous Preset to Registered or Latched Output		15		16	ns
t <sub>APW</sub>	Asynchronous Preset Width (Note 1)	10		12		ns
t <sub>APR</sub>	Asynchronous Preset Recovery Time (Note 1)	10		8		ns
t <sub>EA</sub>	Input, I/O, or Feedback to Output Enable (Note 3)		10		12	ns
t <sub>ER</sub>	Input, I/O, or Feedback to Output Disable (Note 3)		10		12	ns

**Notes:**

1. These parameters are not 100% tested, but are evaluated at initial characterization and at any time the design is modified where capacitance may be affected.
2. See Switching Test Circuit, for test conditions.
3. Parameters measured with 16 outputs switching.

## ABSOLUTE MAXIMUM RATINGS

Storage Temperature	−65°C to +150°C
Ambient Temperature with Power Applied	−55°C to +125°C
Supply Voltage with Respect to Ground	−0.5 V to +7.0 V
DC Input Voltage	−0.5 V to $V_{CC} + 0.5$ V
DC Output or I/O Pin Voltage	−0.5 V to $V_{CC} + 0.5$ V
Static Discharge Voltage	2001 V
Latchup Current ( $T_A = 0^\circ\text{C}$ to $+70^\circ\text{C}$ )	200 mA

Stresses above those listed under Absolute Maximum Ratings may cause permanent device failure. Functionality at or above these limits is not implied. Exposure to Absolute Maximum Ratings for extended periods may affect device reliability. Programming conditions may differ.

## INDUSTRIAL OPERATING RANGES

Temperature ( $T_A$ ) Operating in Free Air	−40°C to +85°C
Supply Voltage ( $V_{CC}$ ) with Respect to Ground	+4.5 V to +5.5 V

Operating ranges define those limits between which the functionality of the device is guaranteed.

## DC CHARACTERISTICS over COMMERCIAL operating ranges unless otherwise specified

Parameter Symbol	Parameter Description	Test Conditions	Min	Typ	Max	Unit
$V_{OH}$	Output HIGH Voltage	$I_{OH} = -3.2$ mA, $V_{CC} = \text{Min}$ $V_{IN} = V_{IH}$ or $V_{IL}$	2.4			V
$V_{OL}$	Output LOW Voltage	$I_{OL} = 16$ mA, $V_{CC} = \text{Min}$ $V_{IN} = V_{IH}$ or $V_{IL}$			0.5	V
$V_{IH}$	Input HIGH Voltage	Guaranteed Input Logical HIGH Voltage for all Inputs (Note 1)	2.0			V
$V_{IL}$	Input LOW Voltage	Guaranteed Input Logical LOW Voltage for all Inputs (Note 1)			0.8	V
$I_{IH}$	Input HIGH Leakage Current	$V_{IN} = 5.25$ V, $V_{CC} = \text{Max}$ (Note 2)			10	$\mu\text{A}$
$I_{IL}$	Input LOW Leakage Current	$V_{IN} = 0$ V, $V_{CC} = \text{Max}$ (Note 2)			−100	$\mu\text{A}$
$I_{OZH}$	Off-State Output Leakage Current HIGH	$V_{OUT} = 5.25$ V, $V_{CC} = \text{Max}$ $V_{IN} = V_{IH}$ or $V_{IL}$ (Note 2)			10	$\mu\text{A}$
$I_{OZL}$	Off-State Output Leakage Current LOW	$V_{OUT} = 0$ V, $V_{CC} = \text{Max}$ $V_{IN} = V_{IH}$ or $V_{IL}$ (Note 2)			−100	$\mu\text{A}$
$I_{SC}$	Output Short-Circuit Current	$V_{OUT} = 0.5$ V, $V_{CC} = \text{Max}$ (Note 3)	−30		−160	mA
$I_{CC}$	Supply Current (Typical)	$V_{CC} = 5$ V, $T_A = 25^\circ\text{C}$ , $f = 25$ MHz (Note 4)		135		mA

### Notes:

- These are absolute values with respect to device ground and all overshoots due to system or tester noise are included.
- I/O pin leakage is the worst case of  $I_{IL}$  and  $I_{OZL}$  (or  $I_{IH}$  and  $I_{OZH}$ ).
- Not more than one output should be shorted at a time and duration of the short-circuit should not exceed one second.  
 $V_{OUT} = 0.5$  V has been chosen to avoid test problems caused by tester ground degradation.
- Measured with a 16-bit up/down counter pattern. This pattern is programmed in each PAL block and is capable of being loaded, enabled, and reset.



## CAPACITANCE (Note 1)

Parameter Symbol	Parameter Description	Test Conditions		Typ	Unit
C <sub>IN</sub>	Input Capacitance	V <sub>IN</sub> = 2.0 V	V <sub>CC</sub> = 5.0 V, T <sub>A</sub> = 25°C, f = 1 MHz	6	pF
C <sub>OUT</sub>	Output Capacitance	V <sub>OUT</sub> = 2.0 V		8	pF

## SWITCHING CHARACTERISTICS over COMMERCIAL operating ranges (Note 2)

Parameter Symbol	Parameter Description		-12		-14		Unit		
			Min	Max	Min	Max			
t <sub>PD</sub>	Input, I/O, or Feedback to Combinatorial Output (Note 3)			12		14.5	ns		
t <sub>S</sub>	Setup Time from Input, I/O, or Feedback to Clock		D-Type		8	8.5	ns		
			T-Type		9	10	ns		
t <sub>H</sub>	Register Data Hold Time		0		0		ns		
t <sub>CO</sub>	Clock to Output (Note 3)			7.5		10	ns		
t <sub>WL</sub>	Clock Width		LOW		6	7.5	ns		
t <sub>WH</sub>			HIGH		6	7.5	ns		
f <sub>MAX</sub>	Maximum Frequency (Note 1)	External Feedback	1/(t <sub>S</sub> + t <sub>CO</sub> )		D-Type		64	53	MHz
			T-Type		59	50	MHz		
		Internal Feedback (f <sub>CNT</sub> )	D-Type		80	61.5	MHz		
			T-Type		72.5	57	MHz		
No Feedback		1/(t <sub>S</sub> + t <sub>H</sub> )		80	66.5	MHz			
t <sub>SL</sub>	Setup Time from Input, I/O, or Feedback to Gate		8		8.5		ns		
t <sub>HL</sub>	Latch Data Hold Time		0		0		ns		
t <sub>GO</sub>	Gate to Output (Note 3)			8.5		12	ns		
t <sub>GWL</sub>	Gate Width LOW		6		7.5		ns		
t <sub>PDL</sub>	Input, I/O, or Feedback to Output Through Transparent Input or Output Latch			14.5		17	ns		
t <sub>SIR</sub>	Input Register Setup Time		2.5		2.5		ns		
t <sub>HIR</sub>	Input Register Hold Time		3		3		ns		
t <sub>ICO</sub>	Input Register Clock to Combinatorial Output			16		18	ns		
t <sub>ICS</sub>	Input Register Clock to Output Register Setup		D-Type		12	14.5	ns		
			T-Type		13	16	ns		
t <sub>WICL</sub>	Input Register Clock Width		LOW		6	7.5	ns		
t <sub>WICH</sub>			HIGH		6	7.5	ns		
f <sub>MAXIR</sub>	Maximum Input Register Frequency	1/(t <sub>WICL</sub> + t <sub>WICH</sub> )		80		66.5	MHz		
t <sub>SIL</sub>	Input Latch Setup Time		2.5		2.5		ns		
t <sub>HIL</sub>	Input Latch Hold Time		3		3		ns		
t <sub>IGO</sub>	Input Latch Gate to Combinatorial Output			17		20.5	ns		
t <sub>IGOL</sub>	Input Latch Gate to Output Through Transparent Output Latch			19.5		23	ns		
t <sub>SLL</sub>	Setup Time from Input, I/O, or Feedback Through Transparent Input Latch to Output Latch Gate		10.5		11		ns		
t <sub>IGS</sub>	Input Latch Gate to Output Latch Setup		13.5		16		ns		

**SWITCHING CHARACTERISTICS over COMMERCIAL operating ranges (Note 2)  
(continued)**

Parameter Symbol	Parameter Description	-12		-14		Unit
		Min	Max	Min	Max	
t <sub>WIGL</sub>	Input Latch Gate Width LOW	6		7.5		ns
t <sub>PDLL</sub>	Input, I/O, or Feedback to Output Through Transparent Input and Output Latches		17		19.5	ns
t <sub>AR</sub>	Asynchronous Reset to Registered or Latched Output		19.5		19.5	ns
t <sub>ARW</sub>	Asynchronous Reset Width (Note 1)	12		14.5		ns
t <sub>ARR</sub>	Asynchronous Reset Recovery Time (Note 1)	12		10		ns
t <sub>AP</sub>	Asynchronous Preset to Registered or Latched Output		18		19.5	ns
t <sub>APW</sub>	Asynchronous Preset Width (Note 1)	12		14.5		ns
t <sub>APR</sub>	Asynchronous Preset Recovery Time (Note 1)	12		10		ns
t <sub>EA</sub>	Input, I/O, or Feedback to Output Enable (Note 3)		12		14.5	ns
t <sub>ER</sub>	Input, I/O, or Feedback to Output Disable (Note 3)		12		14.5	ns

**Notes:**

1. *These parameters are not 100% tested, but are evaluated at initial characterization and at any time the design is modified where capacitance may be affected.*
2. *See Switching Test Circuit, for test conditions.*
3. *Parameters measured with 16 outputs switching.*

**ABSOLUTE MAXIMUM RATINGS**

Storage Temperature	−65°C to +150°C
Ambient Temperature with Power Applied	−55°C to +125°C
Supply Voltage with Respect to Ground	−0.5 V to +7.0 V
DC Input Voltage	−0.5 V to $V_{CC} + 0.5$ V
DC Output or I/O Pin Voltage	−0.5 V to $V_{CC} + 0.5$ V
Static Discharge Voltage	2001 V
Latchup Current ( $T_A = 0^\circ\text{C}$ to $+70^\circ\text{C}$ )	200 mA

Stresses above those listed under Absolute Maximum Ratings may cause permanent device failure. Functionality at or above these limits is not implied. Exposure to Absolute Maximum Ratings for extended periods may affect device reliability. Programming conditions may differ.

**OPERATING RANGES****Commercial (C) Devices**

Temperature ( $T_A$ ) Operating in Free Air	0°C to +70°C
Supply Voltage ( $V_{CC}$ ) with Respect to Ground	+4.75 V to +5.25 V

Operating ranges define those limits between which the functionality of the device is guaranteed.

**DC CHARACTERISTICS over COMMERCIAL operating ranges unless otherwise specified**

Parameter Symbol	Parameter Description	Test Conditions	Min	Typ	Max	Unit
$V_{OH}$	Output HIGH Voltage	$I_{OH} = -3.2$ mA, $V_{CC} = \text{Min}$ $V_{IN} = V_{IH}$ or $V_{IL}$		2.4		V
$V_{OL}$	Output LOW Voltage	$I_{OL} = 16$ mA, $V_{CC} = \text{Min}$ $V_{IN} = V_{IH}$ or $V_{IL}$			0.5	V
$V_{IH}$	Input HIGH Voltage	Guaranteed Input Logical HIGH Voltage for all Inputs (Note 1)	2.0			V
$V_{IL}$	Input LOW Voltage	Guaranteed Input Logical LOW Voltage for all Inputs (Note 1)			0.8	V
$I_{IH}$	Input HIGH Leakage Current	$V_{IN} = 5.25$ V, $V_{CC} = \text{Max}$ (Note 2)			10	$\mu\text{A}$
$I_{IL}$	Input LOW Leakage Current	$V_{IN} = 0$ V, $V_{CC} = \text{Max}$ (Note 2)			−10	$\mu\text{A}$
$I_{OZH}$	Off-State Output Leakage Current HIGH	$V_{OUT} = 5.25$ V, $V_{CC} = \text{Max}$ $V_{IN} = V_{IH}$ or $V_{IL}$ (Note 2)			10	$\mu\text{A}$
$I_{OZL}$	Off-State Output Leakage Current LOW	$V_{OUT} = 0$ V, $V_{CC} = \text{Max}$ $V_{IN} = V_{IH}$ or $V_{IL}$ (Note 2)			−10	$\mu\text{A}$
$I_{SC}$	Output Short-Circuit Current	$V_{OUT} = 0.5$ V, $V_{CC} = \text{Max}$ (Note 3)		−30	−160	mA
$I_{CC}$	Supply Current (Typical)	$V_{CC} = 5$ V, $T_A = 25^\circ\text{C}$ , $f = 25$ MHz (Note 4)		120		mA

**Notes:**

- These are absolute values with respect to device ground and all overshoots due to system or tester noise are included.
- I/O pin leakage is the worst case of  $I_{IL}$  and  $I_{OZL}$  (or  $I_{IH}$  and  $I_{OZH}$ ).
- Not more than one output should be shorted at a time and duration of the short-circuit should not exceed one second.  
 $V_{OUT} = 0.5$  V has been chosen to avoid test problems caused by tester ground degradation.
- Measured with a 16-bit up/down counter pattern. This pattern is programmed in each PAL block and is capable of being loaded, enabled, and reset.

## CAPACITANCE (Note 1)

Parameter Symbol	Parameter Description	Test Conditions		Typ	Unit
C <sub>IN</sub>	Input Capacitance	V <sub>IN</sub> = 2.0 V	V <sub>CC</sub> = 5.0 V, T <sub>A</sub> = 25°C, f = 1 MHz	6	pF
C <sub>OUT</sub>	Output Capacitance	V <sub>OUT</sub> = 2.0 V		8	pF

## SWITCHING CHARACTERISTICS over COMMERCIAL operating ranges (Note 2)

Parameter Symbol	Parameter Description		-12		-15		-20		Unit	
			Min	Max	Min	Max	Min	Max		
t <sub>PD</sub>	Input, I/O, or Feedback to Combinatorial Output (Note 3)			12		15		20	ns	
t <sub>S</sub>	Setup Time from Input, I/O, or Feedback to Clock		D-type	7		10		13	ns	
			T-type	8		11		14	ns	
t <sub>H</sub>	Register Data Hold Time		0		0		0		ns	
t <sub>CO</sub>	Clock to Output (Note 3)			8		10		12	ns	
t <sub>WL</sub>	Clock Width		LOW	6		6		8	ns	
t <sub>WH</sub>			HIGH	6		6		8	ns	
f <sub>MAX</sub>	Maximum Frequency (Note 1)	External Feedback	1/(t <sub>S</sub> + t <sub>CO</sub> )	D-type	66.7		50		40	MHz
			T-type	62.5		47.6		38.5	MHz	
		Internal Feedback (f <sub>CNT</sub> )	D-type	83.3		66.6		50		MHz
			T-type	76.9		62.5		47.6		MHz
No Feedback	1/(t <sub>WL</sub> + t <sub>WH</sub> )	83.3		83.3		62.5		MHz		
t <sub>SL</sub>	Setup Time from Input, I/O, or Feedback to Gate		7		10		13		ns	
t <sub>HL</sub>	Latch Data Hold Time		0		0		0		ns	
t <sub>GO</sub>	Gate to Output (Note 3)			10		11		12	ns	
t <sub>GWL</sub>	Gate Width LOW		6		6		8		ns	
t <sub>PDL</sub>	Input, I/O, or Feedback to Output Through Transparent Input or Output Latch			14		17		22	ns	
t <sub>SIR</sub>	Input Register Setup Time		2		2		2		ns	
t <sub>HIR</sub>	Input Register Hold Time		2		2.5		3		ns	
t <sub>ICO</sub>	Input Register Clock to Combinatorial Output			15		18		23	ns	
t <sub>ICS</sub>	Input Register Clock to Output Register Setup		D-type	12		15		20	ns	
			T-type	13		16		21	ns	
t <sub>WICL</sub>	Input Register Clock Width		LOW	6		6		8	ns	
t <sub>WICH</sub>			HIGH	6		6		8	ns	
f <sub>MAXIR</sub>	Maximum Input Register Frequency	1/(t <sub>WICL</sub> + t <sub>WICH</sub> )	83.3		83.3		62.5		MHz	
t <sub>SIL</sub>	Input Latch Setup Time		2		2		2		ns	
t <sub>HIL</sub>	Input Latch Hold Time		2		2.5		3		ns	
t <sub>IGO</sub>	Input Latch Gate to Combinatorial Output			17		20		25	ns	
t <sub>IGOL</sub>	Input Latch Gate to Output Through Transparent Output Latch			19		22		27	ns	
t <sub>SLL</sub>	Setup Time from Input, I/O, or Feedback Through Transparent Input Latch to Output Latch Gate		9		12		15		ns	
t <sub>IGS</sub>	Input Latch Gate to Output Latch Setup		13		16		21		ns	

**SWITCHING CHARACTERISTICS over COMMERCIAL operating ranges (Note 2)  
(continued)**

Parameter Symbol	Parameter Description	-12		-15		-20		Unit
		Min	Max	Min	Max	Min	Max	
t <sub>WGL</sub>	Input Latch Gate Width LOW	6		6		8		ns
t <sub>PDLL</sub>	Input, I/O, or Feedback to Output Through Transparent Input and Output Latches		16		19		24	ns
t <sub>AR</sub>	Asynchronous Reset to Registered or Latched Output		16		20		25	ns
t <sub>ARW</sub>	Asynchronous Reset Width (Note 1)	12		15		20		ns
t <sub>ARR</sub>	Asynchronous Reset Recovery Time (Note 1)	8		10		15		ns
t <sub>AP</sub>	Asynchronous Preset to Registered or Latched Output		16		20		25	ns
t <sub>APW</sub>	Asynchronous Preset Width (Note 1)	12		15		20		ns
t <sub>APR</sub>	Asynchronous Preset Recovery Time (Note 1)	8		10		15		ns
t <sub>EA</sub>	Input, I/O, or Feedback to Output Enable (Note 3)		12		15		20	ns
t <sub>ER</sub>	Input, I/O, or Feedback to Output Disable (Note 3)		12		15		20	ns

**Notes:**

1. These parameters are not 100% tested, but are evaluated at initial characterization and at any time the design is modified where capacitance may be affected.
2. See Switching Test Circuit, for test conditions.
3. Parameters measured with 16 outputs switching.

## ABSOLUTE MAXIMUM RATINGS

Storage Temperature	−65°C to +150°C
Ambient Temperature	
With Power Applied	−55°C to +125°C
Supply Voltage with Respect to Ground	−0.5 V to +7.0 V
DC Input Voltage	−0.5 V to $V_{CC} + 0.5$ V
DC Output or I/O Pin Voltage	−0.5 V to $V_{CC} + 0.5$ V
Static Discharge Voltage	2001 V
Latchup Current ( $T_A = -40^\circ\text{C}$ to $+85^\circ\text{C}$ )	200 mA

Stresses above those listed under Absolute Maximum Ratings may cause permanent device failure. Functionality at or above these limits is not implied. Exposure to Absolute Maximum Ratings for extended periods may affect device reliability. Programming conditions may differ.

## INDUSTRIAL OPERATING RANGES

Ambient Temperature ( $T_A$ )	
Operating in Free Air	−40°C to +85°C
Supply Voltage ( $V_{CC}$ ) with Respect to Ground	+4.5 V to +5.5 V

Operating ranges define those limits between which the functionality of the device is guaranteed.

## DC CHARACTERISTICS over INDUSTRIAL operating ranges unless otherwise specified

Parameter Symbol	Parameter Description	Test Conditions	Min	Typ	Max	Unit
$V_{OH}$	Output HIGH Voltage	$I_{OH} = -3.2$ mA, $V_{CC} = \text{Min}$ $V_{IN} = V_{IH}$ or $V_{IL}$	2.4			V
$V_{OL}$	Output LOW Voltage	$I_{OL} = 16$ mA, $V_{CC} = \text{Min}$ $V_{IN} = V_{IH}$ or $V_{IL}$			0.5	V
$V_{IH}$	Input HIGH Voltage	Guaranteed Input Logical HIGH Voltage for all Inputs (Note 1)	2.0			V
$V_{IL}$	Input LOW Voltage	Guaranteed Input Logical LOW Voltage for all Inputs (Note 1)			0.8	V
$I_{IH}$	Input HIGH Leakage Current	$V_{IN} = 5.25$ V, $V_{CC} = \text{Max}$ (Note 2)			10	$\mu\text{A}$
$I_{IL}$	Input LOW Leakage Current	$V_{IN} = 0$ V, $V_{CC} = \text{Max}$ (Note 2)			−10	$\mu\text{A}$
$I_{OZH}$	Off-State Output Leakage Current HIGH	$V_{OUT} = 5.25$ V, $V_{CC} = \text{Max}$ $V_{IN} = V_{IH}$ or $V_{IL}$ (Note 2)			10	$\mu\text{A}$
$I_{OZL}$	Off-State Output Leakage Current LOW	$V_{OUT} = 0$ V, $V_{CC} = \text{Max}$ $V_{IN} = V_{IH}$ or $V_{IL}$ (Note 2)			−10	$\mu\text{A}$
$I_{SC}$	Output Short-Circuit Current	$V_{OUT} = 0.5$ V, $V_{CC} = \text{Max}$ (Note 3)	−30		−160	mA
$I_{CC}$	Supply Current (Typical)	$V_{CC} = 5$ V, $T_A = 25^\circ\text{C}$ , $f = 25$ MHz (Note 4)		120		mA

### Notes:

- These are absolute values with respect to device ground and all overshoots due to system and/or tester noise are included.
- I/O pin leakage is the worst case of  $I_{IL}$  and  $I_{OZL}$  (or  $I_{IH}$  and  $I_{OZH}$ ).
- Not more than one output should be shorted at a time. Duration of the short-circuit should not exceed one second.  $V_{OUT} = 0.5$  V has been chosen to avoid test problems caused by tester ground degradation.
- Measured with a 16-bit up/down counter pattern. This pattern is programmed in each PAL block and is capable of being loaded, enabled, and reset.

## CAPACITANCE (Note 1)

Parameter Symbol	Parameter Description	Test Conditions		Typ	Unit
C <sub>IN</sub>	Input Capacitance	V <sub>IN</sub> = 2.0 V	V <sub>CC</sub> = 5.0 V, T <sub>A</sub> = 25°C, f = 1 MHz	6	pF
C <sub>OUT</sub>	Output Capacitance	V <sub>OUT</sub> = 2.0 V		8	pF

## SWITCHING CHARACTERISTICS over INDUSTRIAL operating ranges (Note 2)

Parameter Symbol	Parameter Description		-14		-18		-24		Unit	
			Min	Max	Min	Max	Min	Max		
t <sub>PD</sub>	Input, I/O, or Feedback to Combinatorial Output (Note 3)			14.5		18		24	ns	
t <sub>S</sub>	Setup Time from Input, I/O, or Feedback to Clock		D-type	8.5		12		16	ns	
			T-type	10		13.5		17	ns	
t <sub>H</sub>	Register Data Hold Time		0		0		0		ns	
t <sub>CO</sub>	Clock to Output (Note 3)			10		12		14.5	ns	
t <sub>WL</sub>	Clock Width		LOW	7.5		7.5		10	ns	
t <sub>WH</sub>			HIGH	7.5		7.5		10	ns	
f <sub>MAX</sub>	Maximum Frequency (Note 1)	External Feedback	1/(t <sub>S</sub> + t <sub>CO</sub> )	D-type	53		40		32	MHz
			T-type	50		38		30.5	MHz	
		Internal Feedback (f <sub>CNT</sub> )	D-type	61.5		53		38	MHz	
			T-type	57		44		34.5	MHz	
	No Feedback	1/(t <sub>WL</sub> + t <sub>WH</sub> )	66.5		66.5		50	MHz		
t <sub>SL</sub>	Setup Time from Input, I/O, or Feedback to Gate		8.5		12		16		ns	
t <sub>HL</sub>	Latch Data Hold Time		0		0		0		ns	
t <sub>GO</sub>	Gate to Output (Note 3)			12		13.5		14.5	ns	
t <sub>GWL</sub>	Gate Width LOW		7.5		7.5		10		ns	
t <sub>PDL</sub>	Input, I/O, or Feedback to Output Through Transparent Input or Output Latch			17		20.5		26.5	ns	
t <sub>SIR</sub>	Input Register Setup Time		2.5		2.5		2.5		ns	
t <sub>HIR</sub>	Input Register Hold Time		3		3.5		4		ns	
t <sub>ICO</sub>	Input Register Clock to Combinatorial Output			18		22		28	ns	
t <sub>ICS</sub>	Input Register Clock to Output Register Setup		D-type	14.5		18		24	ns	
			T-type	16		19.5		25.5	ns	
t <sub>WICL</sub>	Input Register Clock Width		LOW	7.5		7.5		10	ns	
t <sub>WICH</sub>			HIGH	7.5		7.5		10	ns	
f <sub>MAXIR</sub>	Maximum Input Register Frequency	1/(t <sub>WICL</sub> + t <sub>WICH</sub> )	66.5		66.5		50		MHz	
t <sub>SIL</sub>	Input Latch Setup Time		2.5		2.5		2.5		ns	
t <sub>HIL</sub>	Input Latch Hold Time		3		3.5		4		ns	
t <sub>IGO</sub>	Input Latch Gate to Combinatorial Output			20.5		24		30	ns	
t <sub>IGOL</sub>	Input Latch Gate to Output Through Transparent Output Latch			23		26.5		32.5	ns	
t <sub>SLL</sub>	Setup Time from Input, I/O, or Feedback Through Transparent Input Latch to Output Latch Gate		11		14.5		18		ns	
t <sub>IGS</sub>	Input Latch Gate to Output Latch Setup		16		19.5		25.5		ns	
t <sub>WIGL</sub>	Input Latch Gate Width LOW		7.5		7.5		10		ns	
t <sub>PDLL</sub>	Input, I/O, or Feedback to Output Through Transparent Input and Output Latches			19.5		23		29	ns	

## SWITCHING CHARACTERISTICS over INDUSTRIAL operating ranges (Note 2) (continued)

Parameter Symbol	Parameter Description	-14		-18		-24		Unit
		Min	Max	Min	Max	Min	Max	
t <sub>AR</sub>	Asynchronous Reset to Registered or Latched Output		19.5		24		30	ns
t <sub>ARW</sub>	Asynchronous Reset Width (Note 1)	14.5		18		24		ns
t <sub>ARR</sub>	Asynchronous Reset Recovery Time (Note 1)	10		12		18		ns
t <sub>AP</sub>	Asynchronous Preset to Registered or Latched Output		19.5		24		30	ns
t <sub>APW</sub>	Asynchronous Preset Width (Note 1)	14.5		18		24		ns
t <sub>APR</sub>	Asynchronous Preset Recovery Time (Note 1)	10		12		18		ns
t <sub>EA</sub>	Input, I/O, or Feedback to Output Enable (Note 3)		14.5		18		24	ns
t <sub>ER</sub>	Input, I/O, or Feedback to Output Disable (Note 3)		14.5		18		24	ns

**Notes:**

1. These parameters are not 100% tested, but are evaluated at initial characterization and at any time the design is modified where capacitance may be affected.
2. See Switching Test Circuit, for test conditions.
3. Parameters measured with 16 outputs switching.



## ABSOLUTE MAXIMUM RATINGS

Storage Temperature	−65°C to +150°C
Ambient Temperature with Power Applied	−55°C to +125°C
Supply Voltage with Respect to Ground	−0.5 V to +7.0 V
DC Input Voltage	−0.5 V to $V_{CC} + 0.5$ V
DC Output or I/O Pin Voltage	−0.5 V to $V_{CC} + 0.5$ V
Static Discharge Voltage	2001 V
Latchup Current ( $T_A = 0^\circ\text{C}$ to $+70^\circ\text{C}$ )	200 mA

Stresses above those listed under Absolute Maximum Ratings may cause permanent device failure. Functionality at or above these limits is not implied. Exposure to Absolute Maximum Ratings for extended periods may affect device reliability. Programming conditions may differ.

## OPERATING RANGES

### Commercial (C) Devices

Temperature ( $T_A$ ) Operating in Free Air	0°C to +70°C
Supply Voltage ( $V_{CC}$ ) with Respect to Ground	+4.75 V to +5.25 V

Operating ranges define those limits between which the functionality of the device is guaranteed.

## DC CHARACTERISTICS over COMMERCIAL operating ranges unless otherwise specified

Parameter Symbol	Parameter Description	Test Conditions	Min	Typ	Max	Unit
$V_{OH}$	Output HIGH Voltage	$I_{OH} = -3.2$ mA, $V_{CC} = \text{Min}$ $V_{IN} = V_{IH}$ or $V_{IL}$	2.4			V
$V_{OL}$	Output LOW Voltage	$I_{OL} = 16$ mA, $V_{CC} = \text{Min}$ $V_{IN} = V_{IH}$ or $V_{IL}$			0.5	V
$V_{IH}$	Input HIGH Voltage	Guaranteed Input Logical HIGH Voltage for all Inputs (Note 1)	2.0			V
$V_{IL}$	Input LOW Voltage	Guaranteed Input Logical LOW Voltage for all Inputs (Note 1)			0.8	V
$I_{IH}$	Input HIGH Leakage Current	$V_{IN} = 5.25$ V, $V_{CC} = \text{Max}$ (Note 2)			10	$\mu\text{A}$
$I_{IL}$	Input LOW Leakage Current	$V_{IN} = 0$ V, $V_{CC} = \text{Max}$ (Note 2)			−100	$\mu\text{A}$
$I_{OZH}$	Off-State Output Leakage Current HIGH	$V_{OUT} = 5.25$ V, $V_{CC} = \text{Max}$ $V_{IN} = V_{IH}$ or $V_{IL}$ (Note 2)			10	$\mu\text{A}$
$I_{OZL}$	Off-State Output Leakage Current LOW	$V_{OUT} = 0$ V, $V_{CC} = \text{Max}$ $V_{IN} = V_{IH}$ or $V_{IL}$ (Note 2)			−100	$\mu\text{A}$
$I_{SC}$	Output Short-Circuit Current	$V_{OUT} = 0.5$ V, $V_{CC} = \text{Max}$ (Note 3)	−30		−160	mA
$I_{CC}$	Supply Current (Typical)	$V_{CC} = 5$ V, $T_A = 25^\circ\text{C}$ , $f = 25$ MHz (Note 4)		45		mA

### Notes:

- These are absolute values with respect to device ground and all overshoots due to system or tester noise are included.
- I/O pin leakage is the worst case of  $I_{IL}$  and  $I_{OZL}$  (or  $I_{IH}$  and  $I_{OZH}$ ).
- Not more than one output should be shorted at a time and duration of the short-circuit should not exceed one second.  
 $V_{OUT} = 0.5$  V has been chosen to avoid test problems caused by tester ground degradation.
- Measured with a 16-bit up/down counter pattern. This pattern is programmed in each PAL block and is capable of being loaded, enabled, and reset.

## CAPACITANCE (Note 1)

Parameter Symbol	Parameter Description	Test Conditions		Typ	Unit
C <sub>IN</sub>	Input Capacitance	V <sub>IN</sub> = 2.0 V	V <sub>CC</sub> = 5.0 V, T <sub>A</sub> = 25°C, f = 1 MHz	6	pF
C <sub>OUT</sub>	Output Capacitance	V <sub>OUT</sub> = 2.0 V		8	pF

## SWITCHING CHARACTERISTICS over COMMERCIAL operating ranges (Note 2)

Parameter Symbol	Parameter Description		-12		Unit
			Min	Max	
t <sub>PD</sub>	Input, I/O, or Feedback to Combinatorial Output			12	ns
t <sub>S</sub>	Setup Time from Input, I/O, or Feedback to Clock		D-type	12	ns
			T-type	13	ns
t <sub>H</sub>	Register Data Hold Time		0		ns
t <sub>CO</sub>	Clock to Output			6	ns
t <sub>WL</sub>	Clock Width	LOW	6		ns
t <sub>WH</sub>		HIGH	6		ns
f <sub>MAX</sub>	Maximum Frequency (Note 1)	External Feedback	D-type	55.6	MHz
			T-type	52.6	MHz
		Internal Feedback (fcNT)	D-type	83.3	MHz
			T-type	76.9	MHz
No Feedback			83.3	MHz	
t <sub>SL</sub>	Setup Time from Input, I/O, or Feedback to Gate		12		ns
t <sub>HL</sub>	Latch Data Hold Time		0		ns
t <sub>GO</sub>	Gate to Output			7	ns
t <sub>GWL</sub>	Gate Width LOW		6		ns
t <sub>PDL</sub>	Input, I/O, or Feedback to Output Through Transparent Input or Output Latch			14	ns
t <sub>SIR</sub>	Input Register Setup Time		2		ns
t <sub>HIR</sub>	Input Register Hold Time		2.5		ns
t <sub>ICO</sub>	Input Register Clock to Combinatorial Output			17	ns
t <sub>ICS</sub>	Input Register Clock to Output Register Setup		D-type	15	ns
			T-type	16	ns
t <sub>WCL</sub>	Input Register Clock Width	LOW	6	ns	
t <sub>WCH</sub>		HIGH	6	ns	
f <sub>MAXIR</sub>	Maximum Input Register Frequency		83.3		MHz
t <sub>SIL</sub>	Input Latch Setup Time		2		ns
t <sub>HIL</sub>	Input Latch Hold Time		2.5		ns
t <sub>IGO</sub>	Input Latch Gate to Combinatorial Output			19	ns
t <sub>IGOL</sub>	Input Latch Gate to Output Through Transparent Output Latch			20	ns
t <sub>SLL</sub>	Setup Time from Input, I/O, or Feedback Through Transparent Input Latch to Output Latch Gate		13		ns
t <sub>IGS</sub>	Input Latch Gate to Output Latch Setup		16		ns

**SWITCHING CHARACTERISTICS over COMMERCIAL operating ranges (Note 2)  
(continued)**

Parameter Symbol	Parameter Description	-12		Unit
		Min	Max	
$t_{WGL}$	Input Latch Gate Width LOW	6		ns
$t_{PDL}$	Input, I/O, or Feedback to Output Through Transparent Input and Output Latches		18	ns
$t_{AR}$	Asynchronous Reset to Registered or Latched Output		24	ns
$t_{ARW}$	Asynchronous Reset Width (Note 1)	19		ns
$t_{ARR}$	Asynchronous Reset Recovery Time (Note 1)	19		ns
$t_{AP}$	Asynchronous Preset to Registered or Latched Output		24	ns
$t_{APW}$	Asynchronous Preset Width (Note 1)	19		ns
$t_{APR}$	Asynchronous Preset Recovery Time (Note 1)	19		ns
$t_{EA}$	Input, I/O, or Feedback to Output Enable		12	ns
$t_{ER}$	Input, I/O, or Feedback to Output Disable		12	ns

**Notes:**

1. These parameters are not 100% tested, but are evaluated at initial characterization and at any time the design is modified where capacitance may be affected.
2. See Switching Test Circuit, for test conditions.

## ABSOLUTE MAXIMUM RATINGS

Storage Temperature	−65°C to +150°C
Ambient Temperature with Power Applied	−55°C to +125°C
Supply Voltage with Respect to Ground	−0.5 V to +7.0 V
DC Input Voltage	−0.5 V to $V_{CC} + 0.5$ V
DC Output or I/O Pin Voltage	−0.5 V to $V_{CC} + 0.5$ V
Static Discharge Voltage	2001 V
Latchup Current ( $T_A = 0^\circ\text{C}$ to $+70^\circ\text{C}$ )	200 mA

Stresses above those listed under Absolute Maximum Ratings may cause permanent device failure. Functionality at or above these limits is not implied. Exposure to Absolute Maximum Ratings for extended periods may affect device reliability. Programming conditions may differ.

## OPERATING RANGES

### Commercial (C) Devices

Temperature ( $T_A$ ) Operating in Free Air	0°C to +70°C
Supply Voltage ( $V_{CC}$ ) with Respect to Ground	+4.75 V to +5.25 V

Operating ranges define those limits between which the functionality of the device is guaranteed.

## DC CHARACTERISTICS over COMMERCIAL operating ranges unless otherwise specified

Parameter Symbol	Parameter Description	Test Conditions	Min	Typ	Max	Unit
$V_{OH}$	Output HIGH Voltage	$I_{OH} = -3.2$ mA, $V_{CC} = \text{Min}$ $V_{IN} = V_{IH}$ or $V_{IL}$	2.4			V
$V_{OL}$	Output LOW Voltage	$I_{OL} = 16$ mA, $V_{CC} = \text{Min}$ $V_{IN} = V_{IH}$ or $V_{IL}$			0.5	V
$V_{IH}$	Input HIGH Voltage	Guaranteed Input Logical HIGH Voltage for all Inputs (Note 1)	2.0			V
$V_{IL}$	Input LOW Voltage	Guaranteed Input Logical LOW Voltage for all Inputs (Note 1)			0.8	V
$I_{IH}$	Input HIGH Leakage Current	$V_{IN} = 5.25$ V, $V_{CC} = \text{Max}$ (Note 2)			10	$\mu\text{A}$
$I_{IL}$	Input LOW Leakage Current	$V_{IN} = 0$ V, $V_{CC} = \text{Max}$ (Note 2)			−100	$\mu\text{A}$
$I_{OZH}$	Off-State Output Leakage Current HIGH	$V_{OUT} = 5.25$ V, $V_{CC} = \text{Max}$ $V_{IN} = V_{IH}$ or $V_{IL}$ (Note 2)			10	$\mu\text{A}$
$I_{OZL}$	Off-State Output Leakage Current LOW	$V_{OUT} = 0$ V, $V_{CC} = \text{Max}$ $V_{IN} = V_{IH}$ or $V_{IL}$ (Note 2)			−100	$\mu\text{A}$
$I_{SC}$	Output Short-Circuit Current	$V_{OUT} = 0.5$ V, $V_{CC} = \text{Max}$ (Note 3)	−30		−160	mA
$I_{CC}$	Supply Current (Typical)	$V_{CC} = 5$ V, $T_A = 25^\circ\text{C}$ , $f = 25$ MHz (Note 4)		45		mA

### Notes:

- These are absolute values with respect to device ground and all overshoots due to system or tester noise are included.
- I/O pin leakage is the worst case of  $I_{IL}$  and  $I_{OZL}$  (or  $I_{IH}$  and  $I_{OZH}$ ).
- Not more than one output should be shorted at a time and duration of the short-circuit should not exceed one second.  
 $V_{OUT} = 0.5$  V has been chosen to avoid test problems caused by tester ground degradation.
- Measured with a 16-bit up/down counter pattern. This pattern is programmed in each PAL block and is capable of being loaded, enabled, and reset.

## CAPACITANCE (Note 1)

Parameter Symbol	Parameter Description	Test Conditions		Typ	Unit
C <sub>IN</sub>	Input Capacitance	V <sub>IN</sub> = 2.0 V	V <sub>CC</sub> = 5.0 V, T <sub>A</sub> = 25°C, f = 1 MHz	6	pF
C <sub>OUT</sub>	Output Capacitance	V <sub>OUT</sub> = 2.0 V		8	pF

## SWITCHING CHARACTERISTICS over COMMERCIAL operating ranges (Note 2)

Parameter Symbol	Parameter Description			-15		-20		Unit
				Min	Max	Min	Max	
t <sub>PD</sub>	Input, I/O, or Feedback to Combinatorial Output (Note 3)				15		20	ns
t <sub>S</sub>	Setup Time from Input, I/O, or Feedback to Clock		D-type	13		17		ns
			T-type	14		18		ns
t <sub>H</sub>	Register Data Hold Time			0		0		ns
t <sub>CO</sub>	Clock to Output (Note 3)				7		8	ns
t <sub>WL</sub>	Clock Width		LOW	6		8		ns
t <sub>WH</sub>			HIGH	6		8		ns
f <sub>MAX</sub>	Maximum Frequency (Note 1)	External Feedback	1/(t <sub>S</sub> + t <sub>CO</sub> )	D-type	50		40	MHz
			T-type	47.6		38.4	MHz	
		Internal Feedback (f <sub>CNT</sub> )	D-type	58.8		45.4	MHz	
			T-type	55.5		43.4	MHz	
		No Feedback	1/(t <sub>S</sub> + t <sub>H</sub> )	D-type	76.9		58.8	MHz
				T-type	71.4		55.5	MHz
t <sub>SL</sub>	Setup Time from Input, I/O, or Feedback to Gate			13		17		ns
t <sub>HL</sub>	Latch Data Hold Time			0		0		ns
t <sub>GO</sub>	Gate to Output (Note 3)				8		8	ns
t <sub>GWL</sub>	Gate Width LOW			6		8		ns
t <sub>PDL</sub>	Input, I/O, or Feedback to Output Through Transparent Input or Output Latch				17		22	ns
t <sub>SIR</sub>	Input Register Setup Time			2		2		ns
t <sub>HIR</sub>	Input Register Hold Time			2.5		3		ns
t <sub>ICO</sub>	Input Register Clock to Combinatorial Output				18		23	ns
t <sub>ICS</sub>	Input Register Clock to Output Register Setup		D-type	17		22		ns
			T-type	18		23		ns
t <sub>WICL</sub>	Input Register Clock Width		LOW	6		8		ns
t <sub>WICH</sub>			HIGH	6		8		ns
f <sub>MAXIR</sub>	Maximum Input Register Frequency	1/(t <sub>WICL</sub> + t <sub>WICH</sub> )		83.3		62.5		MHz
t <sub>SIL</sub>	Input Latch Setup Time			2		2		ns
t <sub>HIL</sub>	Input Latch Hold Time			2.5		3		ns
t <sub>IGO</sub>	Input Latch Gate to Combinatorial Output				20		25	ns
t <sub>IGOL</sub>	Input Latch Gate to Output Through Transparent Output Latch				22		27	ns
t <sub>SLL</sub>	Setup Time from Input, I/O, or Feedback Through Transparent Input Latch to Output Latch Gate			15		19		ns
t <sub>IGS</sub>	Input Latch Gate to Output Latch Setup			18		23		ns

**SWITCHING CHARACTERISTICS over COMMERCIAL operating ranges (Note 2)  
(continued)**

Parameter Symbol	Parameter Description	-15		-20		Unit
		Min	Max	Min	Max	
t <sub>WIGL</sub>	Input Latch Gate Width LOW	6		8		ns
t <sub>PDLL</sub>	Input, I/O, or Feedback to Output Through Transparent Input and Output Latches		19		24	ns
t <sub>AR</sub>	Asynchronous Reset to Registered or Latched Output		25		30	ns
t <sub>ARW</sub>	Asynchronous Reset Width (Note 1)	20		25		ns
t <sub>ARR</sub>	Asynchronous Reset Recovery Time (Note 1)	20		25		ns
t <sub>AP</sub>	Asynchronous Preset to Registered or Latched Output		25		30	ns
t <sub>APW</sub>	Asynchronous Preset Width (Note 1)	20		25		ns
t <sub>APR</sub>	Asynchronous Preset Recovery Time (Note 1)	20		25		ns
t <sub>EA</sub>	Input, I/O, or Feedback to Output Enable (Note 3)		15		20	ns
t <sub>ER</sub>	Input, I/O, or Feedback to Output Disable (Note 3)		15		20	ns

**Notes:**

1. *These parameters are not 100% tested, but are evaluated at initial characterization and at any time the design is modified where capacitance may be affected.*
2. *See Switching Test Circuit, for test conditions.*
3. *Parameters measured with 16 outputs switching.*

## ABSOLUTE MAXIMUM RATINGS

Storage Temperature	−65°C to +150°C
Ambient Temperature	
With Power Applied	−55°C to +125°C
Supply Voltage with Respect to Ground	−0.5 V to +7.0 V
DC Input Voltage	−0.5 V to $V_{CC} + 0.5$ V
DC Output or I/O Pin Voltage	−0.5 V to $V_{CC} + 0.5$ V
Static Discharge Voltage	2001 V
Latchup Current ( $T_A = -40^\circ\text{C}$ to $+85^\circ\text{C}$ )	200 mA

Stresses above those listed under Absolute Maximum Ratings may cause permanent device failure. Functionality at or above these limits is not implied. Exposure to Absolute Maximum Ratings for extended periods may affect device reliability. Programming conditions may differ.

## INDUSTRIAL OPERATING RANGES

Ambient Temperature ( $T_A$ )	
Operating in Free Air	−40°C to +85°C
Supply Voltage ( $V_{CC}$ ) with Respect to Ground	+4.5 V to +5.5 V

Operating ranges define those limits between which the functionality of the device is guaranteed.

## DC CHARACTERISTICS over INDUSTRIAL operating ranges unless otherwise specified

Parameter Symbol	Parameter Description	Test Conditions	Min	Typ	Max	Unit
$V_{OH}$	Output HIGH Voltage	$I_{OH} = -3.2$ mA, $V_{CC} = \text{Min}$ $V_{IN} = V_{IH}$ or $V_{IL}$	2.4			V
$V_{OL}$	Output LOW Voltage	$I_{OL} = 16$ mA, $V_{CC} = \text{Min}$ $V_{IN} = V_{IH}$ or $V_{IL}$			0.5	V
$V_{IH}$	Input HIGH Voltage	Guaranteed Input Logical HIGH Voltage for all Inputs (Note 1)	2.0			V
$V_{IL}$	Input LOW Voltage	Guaranteed Input Logical LOW Voltage for all Inputs (Note 1)			0.8	V
$I_{IH}$	Input HIGH Leakage Current	$V_{IN} = 5.25$ V, $V_{CC} = \text{Max}$ (Note 2)			10	$\mu\text{A}$
$I_{IL}$	Input LOW Leakage Current	$V_{IN} = 0$ V, $V_{CC} = \text{Max}$ (Note 2)			−100	$\mu\text{A}$
$I_{OZH}$	Off-State Output Leakage Current HIGH	$V_{OUT} = 5.25$ V, $V_{CC} = \text{Max}$ $V_{IN} = V_{IH}$ or $V_{IL}$ (Note 2)			10	$\mu\text{A}$
$I_{OZL}$	Off-State Output Leakage Current LOW	$V_{OUT} = 0$ V, $V_{CC} = \text{Max}$ $V_{IN} = V_{IH}$ or $V_{IL}$ (Note 2)			−100	$\mu\text{A}$
$I_{SC}$	Output Short-Circuit Current	$V_{OUT} = 0.5$ V, $V_{CC} = \text{Max}$ (Note 3)	−30		−160	mA
$I_{CC}$	Supply Current (Typical)	$V_{CC} = 5$ V, $T_A = 25^\circ\text{C}$ , $f = 25$ MHz (Note 4)		45		mA

### Notes:

- These are absolute values with respect to device ground and all overshoots due to system and/or tester noise are included.
- I/O pin leakage is the worst case of  $I_{IL}$  and  $I_{OZL}$  (or  $I_{IH}$  and  $I_{OZH}$ ).
- Not more than one output should be shorted at a time. Duration of the short-circuit should not exceed one second.  $V_{OUT} = 0.5$  V has been chosen to avoid test problems caused by tester ground degradation.
- Measured with a 16-bit up/down counter pattern. This pattern is programmed in each PAL block and is capable of being loaded, enabled, and reset.

## CAPACITANCE (Note 1)

Parameter Symbol	Parameter Description	Test Conditions		Typ	Unit
C <sub>IN</sub>	Input Capacitance	V <sub>IN</sub> = 2.0 V	V <sub>CC</sub> = 5.0 V, T <sub>A</sub> = 25°C, f = 1 MHz	6	pF
C <sub>OUT</sub>	Output Capacitance	V <sub>OUT</sub> = 2.0 V		8	pF

## SWITCHING CHARACTERISTICS over INDUSTRIAL operating ranges (Note 2)

Parameter Symbol	Parameter Description		-18		-24		Unit		
			Min	Max	Min	Max			
t <sub>PD</sub>	Input, I/O, or Feedback to Combinatorial Output (Note 3)			18		24	ns		
t <sub>S</sub>	Setup Time from Input, I/O, or Feedback to Clock		D-type		16	20.5	ns		
			T-type		17	22	ns		
t <sub>H</sub>	Register Data Hold Time		0		0		ns		
t <sub>CO</sub>	Clock to Output (Note 3)			8.5		10	ns		
t <sub>WL</sub>	Clock Width		LOW		7.5	10	ns		
t <sub>WH</sub>			HIGH		7.5	10	ns		
f <sub>MAX</sub>	Maximum Frequency (Note 1)	External Feedback	1/(t <sub>S</sub> + t <sub>CO</sub> )		D-type		40	32	MHz
		Internal Feedback (f <sub>CNT</sub> )		D-type		47	36	MHz	
	Internal Feedback (f <sub>CNT</sub> )		T-type		38	30.5	MHz		
	Internal Feedback (f <sub>CNT</sub> )		D-type		44	34.5	MHz		
	No Feedback		1/(t <sub>S</sub> + t <sub>H</sub> )		D-type		61.5	47	MHz
	No Feedback		1/(t <sub>S</sub> + t <sub>H</sub> )		T-type		57	47	MHz
t <sub>SL</sub>	Setup Time from Input, I/O, or Feedback to Gate		16		20.5		ns		
t <sub>HL</sub>	Latch Data Hold Time		0		0		ns		
t <sub>GO</sub>	Gate to Output (Note 3)			10		10	ns		
t <sub>GWL</sub>	Gate Width LOW		7.5		10		ns		
t <sub>PDL</sub>	Input, I/O, or Feedback to Output Through Transparent Input or Output Latch			20.5		26.5	ns		
t <sub>SIR</sub>	Input Register Setup Time		2.5		2.5		ns		
t <sub>HIR</sub>	Input Register Hold Time		3.5		4		ns		
t <sub>ICO</sub>	Input Register Clock to Combinatorial Output			22		28	ns		
t <sub>ICS</sub>	Input Register Clock to Output Register Setup		D-type		20.5	26.5	ns		
			T-type		22	28	ns		
t <sub>WICL</sub>	Input Register Clock Width		LOW		7.5	10	ns		
t <sub>WICH</sub>			HIGH		7.5	10	ns		
f <sub>MAXIR</sub>	Maximum Input Register Frequency	1/(t <sub>WICL</sub> + t <sub>WICH</sub> )		66.5		50	MHz		
t <sub>SIL</sub>	Input Latch Setup Time		2.5		2.5		ns		
t <sub>HIL</sub>	Input Latch Hold Time		3.5		4		ns		
t <sub>IGO</sub>	Input Latch Gate to Combinatorial Output			24		30	ns		
t <sub>IGOL</sub>	Input Latch Gate to Output Through Transparent Output Latch			26.5		32.5	ns		
t <sub>SLL</sub>	Setup Time from Input, I/O, or Feedback Through Transparent Input Latch to Output Latch Gate		18		23		ns		
t <sub>IGS</sub>	Input Latch Gate to Output Latch Setup		22		28		ns		
t <sub>WIGL</sub>	Input Latch Gate Width LOW		7.5		10		ns		
t <sub>PDLL</sub>	Input, I/O, or Feedback to Output Through Transparent Input and Output Latches			23		29	ns		



## SWITCHING CHARACTERISTICS over INDUSTRIAL operating ranges (Note 2) (continued)

Parameter Symbol	Parameter Description	-18		-24		Unit
		Min	Max	Min	Max	
t <sub>AR</sub>	Asynchronous Reset to Registered or Latched Output		30		36	ns
t <sub>ARW</sub>	Asynchronous Reset Width (Note 1)	24		30		ns
t <sub>ARR</sub>	Asynchronous Reset Recovery Time (Note 1)	24		30		ns
t <sub>AP</sub>	Asynchronous Preset to Registered or Latched Output		30		36	ns
t <sub>APW</sub>	Asynchronous Preset Width (Note 1)	24		30		ns
t <sub>APR</sub>	Asynchronous Preset Recovery Time (Note 1)	24		30		ns
t <sub>EA</sub>	Input, I/O, or Feedback to Output Enable (Note 3)		18		24	ns
t <sub>ER</sub>	Input, I/O, or Feedback to Output Disable (Note 3)		18		24	ns

**Notes:**

1. These parameters are not 100% tested, but are evaluated at initial characterization and at any time the design is modified where capacitance may be affected.
2. See Switching Test Circuit, for test conditions.
3. Parameters measured with 16 outputs switching.

**TYPICAL CURRENT VS. VOLTAGE (I-V) CHARACTERISTICS**

$V_{CC} = 5.0\text{ V}$ ,  $T_A = 25^\circ\text{C}$

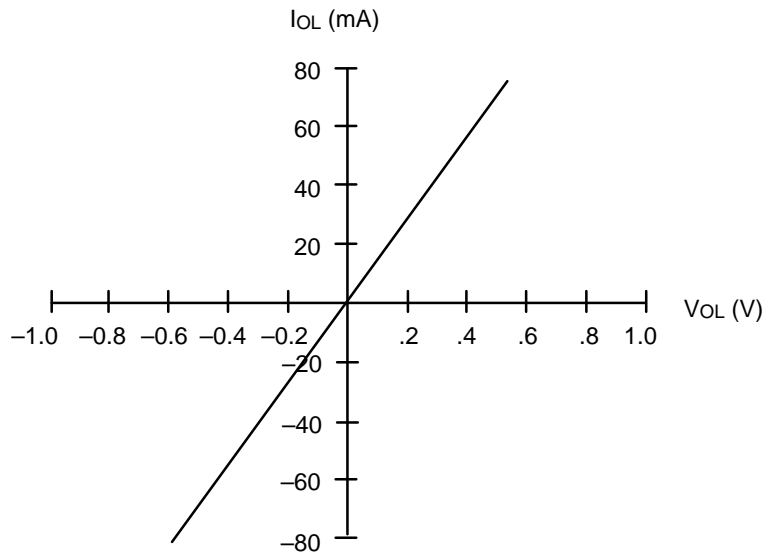

141281-5

**Output, LOW**

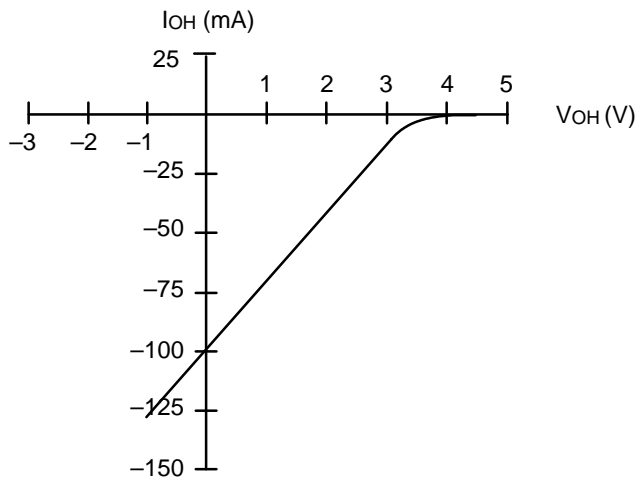

141281-6

**Output, HIGH**

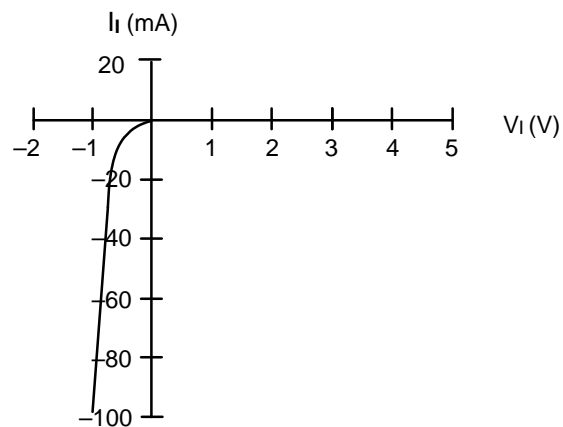

141281-7

**Input**

## TYPICAL $I_{CC}$ CHARACTERISTICS

$V_{CC} = 5\text{ V}$ ,  $T_A = 25^\circ\text{C}$

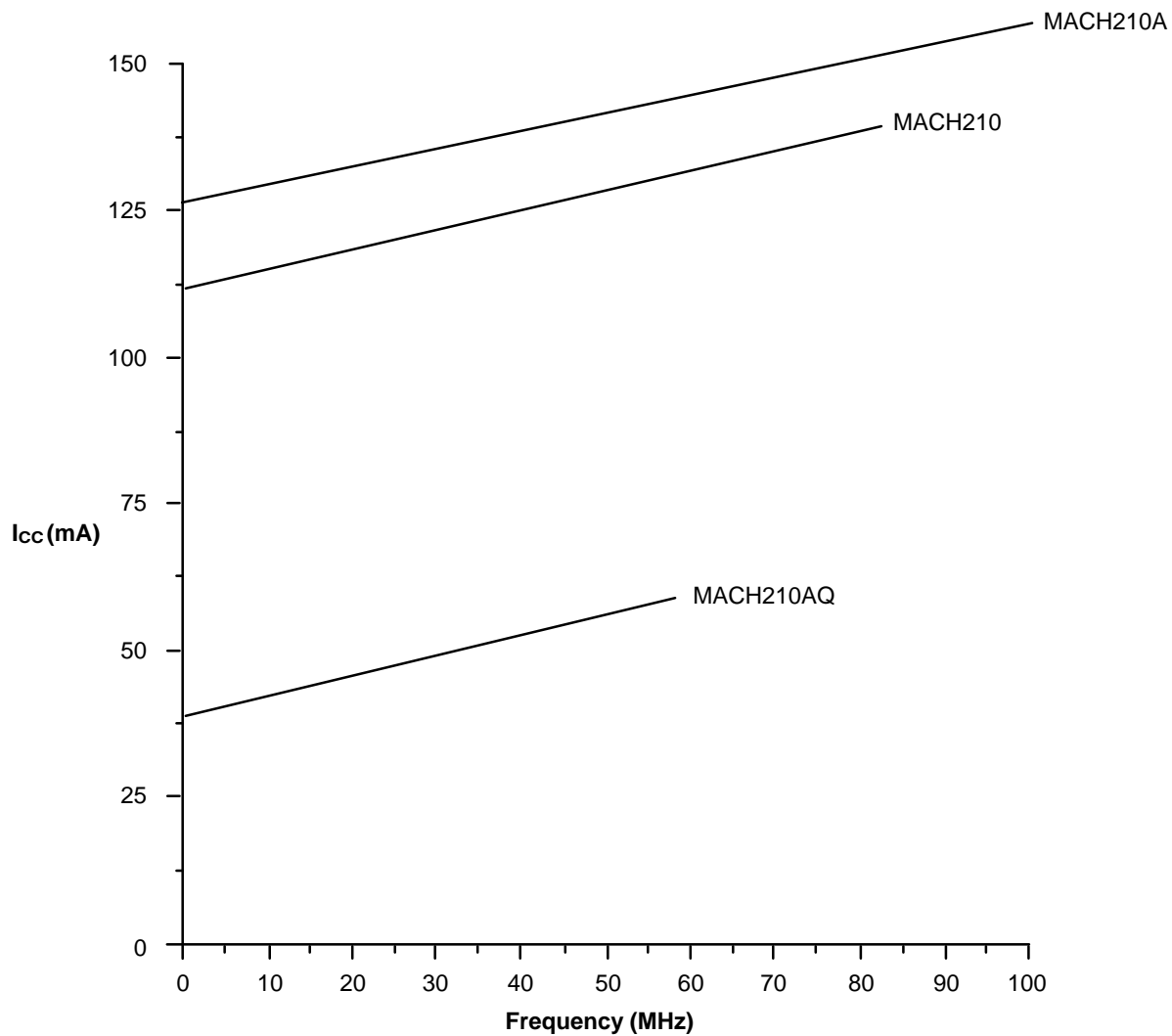

14128I-8

The selected "typical" pattern is a 16-bit up/down counter. This pattern is programmed in each PAL block and is capable of being loaded, enabled, and reset.

Maximum frequency shown uses internal feedback and a D-type register.

## TYPICAL THERMAL CHARACTERISTICS

Measured at 25°C ambient. These parameters are not tested.

Parameter Symbol	Parameter Description	Typ		Unit	
		TQFP	PLCC		
$\theta_{jc}$	Thermal impedance, junction to case	11.3	15	°C/W	
$\theta_{ja}$	Thermal impedance, junction to ambient	41	40	°C/W	
$\theta_{jma}$	Thermal impedance, junction to ambient with air flow	200 lfpm air	35	36	°C/W
		400 lfpm air	33.7	33	°C/W
		600 lfpm air	32.6	31	°C/W
		800 lfpm air	32	29	°C/W

### **Plastic $\theta_{jc}$ Considerations**

*The data listed for plastic  $\theta_{jc}$  are for reference only and are not recommended for use in calculating junction temperatures. The heat-flow paths in plastic-encapsulated devices are complex, making the  $\theta_{jc}$  measurement relative to a specific location on the package surface. Tests indicate this measurement reference point is directly below the die-attach area on the bottom center of the package. Furthermore,  $\theta_{jc}$  tests on packages are performed in a constant-temperature bath, keeping the package surface at a constant temperature. Therefore, the measurements can only be used in a similar environment.*

# SWITCHING WAVEFORMS

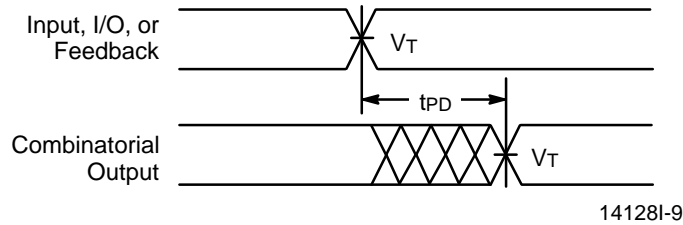

**Combinatorial Output**

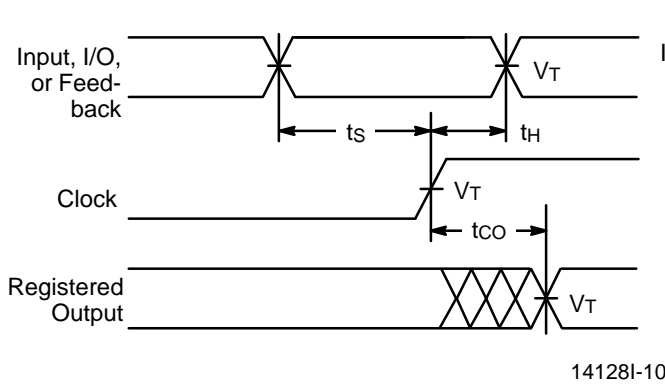

**Registered Output**

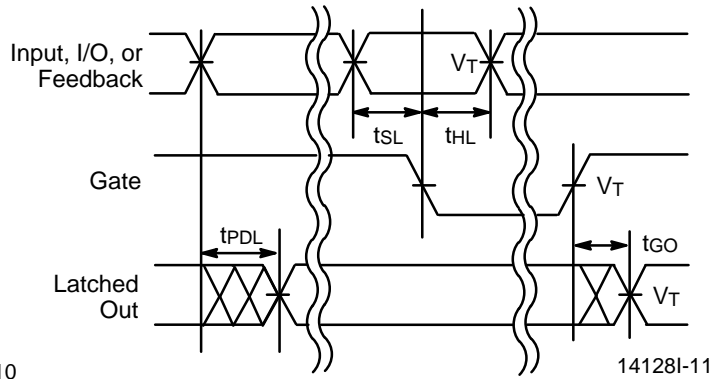

**Latched Output (MACH 2, 3, and 4)**

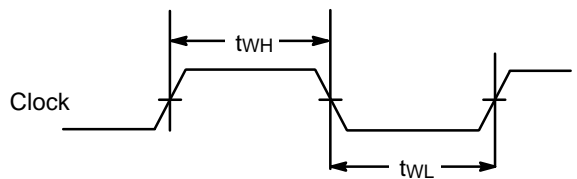

**Clock Width**

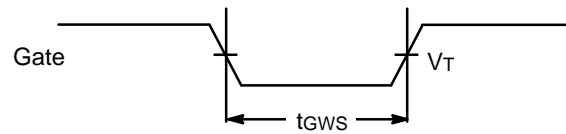

**Gate Width (MACH 2, 3, and 4)**

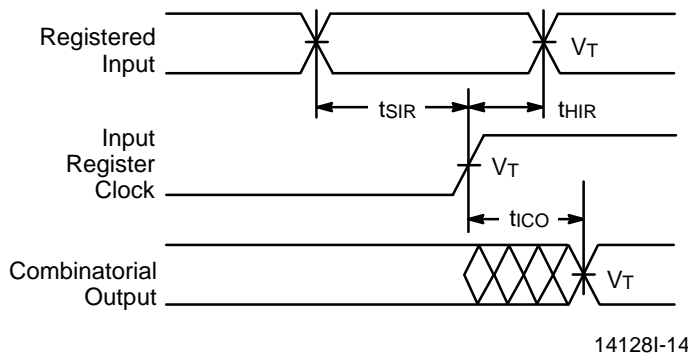

**Registered Input (MACH 2 and 4)**

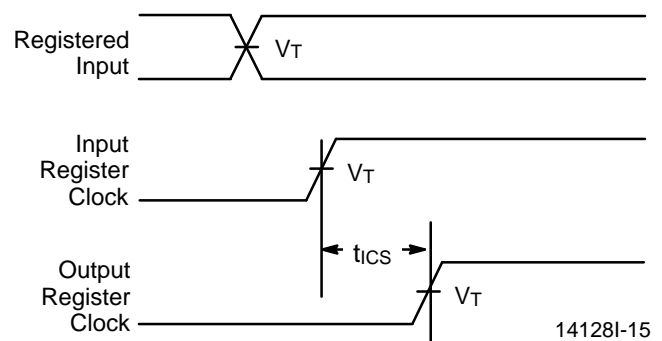

**Input Register to Output Register Setup (MACH 2 and 4)**

**Notes:**

1.  $V_T = 1.5 V$ .
2. Input pulse amplitude 0 V to 3.0 V.
3. Input rise and fall times 2 ns–4 ns typical.

SWITCHING WAVEFORMS

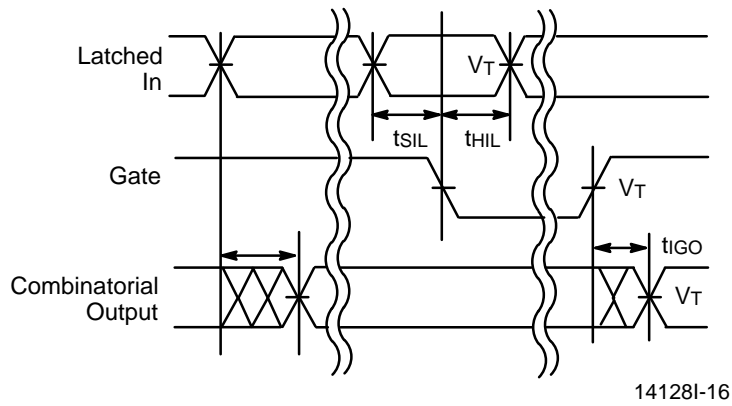

Latched Input (MACH 2 and 4)

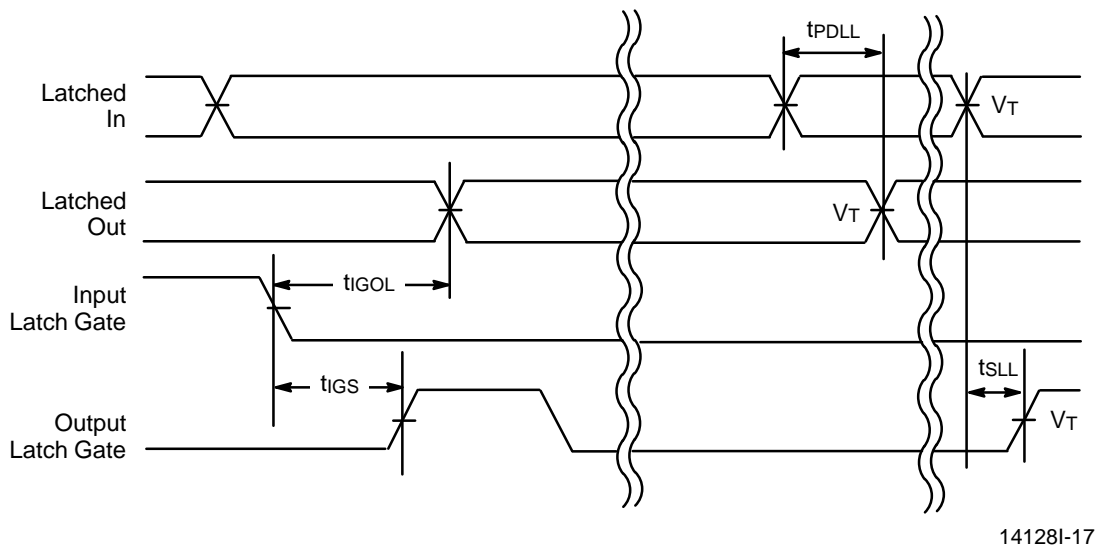

Latched Input and Output (MACH 2, 3, and 4)

Notes:

1.  $V_T = 1.5\text{ V}$ .
2. Input pulse amplitude 0 V to 3.0 V.
3. Input rise and fall times 2 ns–4 ns typical.

## SWITCHING WAVEFORMS

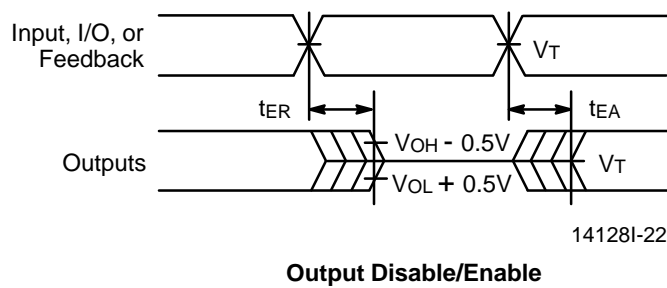
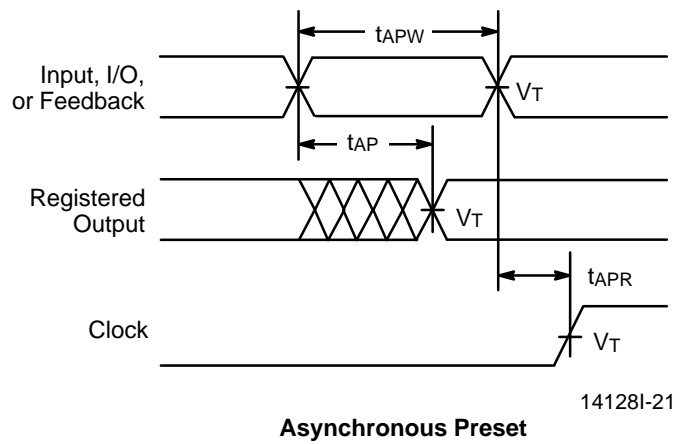
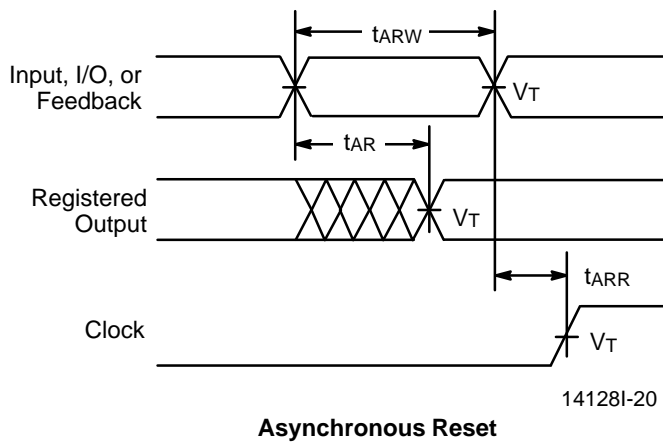
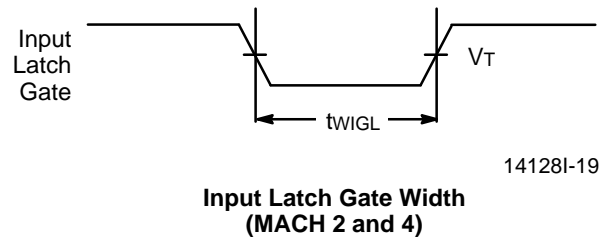
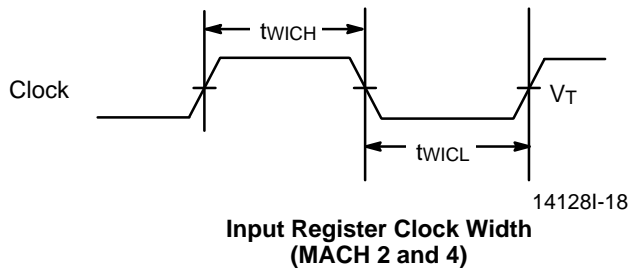

**Notes:**

1.  $V_T = 1.5\text{ V}$ .
2. Input pulse amplitude 0 V to 3.0 V.
3. Input rise and fall times 2 ns–4 ns typical.

## KEY TO SWITCHING WAVEFORMS

WAVEFORM	INPUTS	OUTPUTS
	Must be Steady	Will be Steady
	May Change from H to L	Will be Changing from H to L
	May Change from L to H	Will be Changing from L to H
	Don't Care, Any Change Permitted	Changing, State Unknown
	Does Not Apply	Center Line is High-Impedance "Off" State

KS000010-PAL

## SWITCHING TEST CIRCUIT

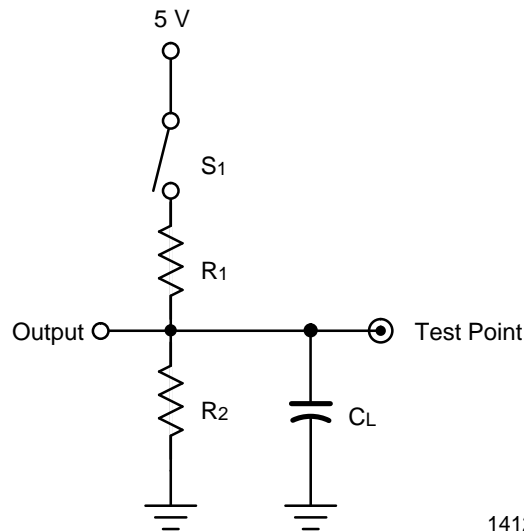

14128I-23

Specification	S <sub>1</sub>	C <sub>L</sub>	Commercial		Measured Output Value
			R <sub>1</sub>	R <sub>2</sub>	
t <sub>PD</sub> , t <sub>CO</sub>	Closed	35 pF	300 Ω	390 Ω	1.5 V
t <sub>EA</sub>	Z → H: Open Z → L: Closed				1.5 V
t <sub>ER</sub>	H → Z: Open L → Z: Closed	5 pF			H → Z: V <sub>OH</sub> - 0.5 V L → Z: V <sub>OL</sub> + 0.5 V

\*Switching several outputs simultaneously should be avoided for accurate measurement.



## f<sub>MAX</sub> PARAMETERS

The parameter f<sub>MAX</sub> is the maximum clock rate at which the device is guaranteed to operate. Because the flexibility inherent in programmable logic devices offers a choice of clocked flip-flop designs, f<sub>MAX</sub> is specified for three types of synchronous designs.

The first type of design is a state machine with feedback signals sent off-chip. This external feedback could go back to the device inputs, or to a second device in a multi-chip state machine. The slowest path defining the period is the sum of the clock-to-output time and the input setup time for the external signals (t<sub>s</sub> + t<sub>CO</sub>). The reciprocal, f<sub>MAX</sub>, is the maximum frequency with external feedback or in conjunction with an equivalent speed device. This f<sub>MAX</sub> is designated “f<sub>MAX</sub> external.”

The second type of design is a single-chip state machine with internal feedback only. In this case, flip-flop inputs are defined by the device inputs and flip-flop outputs. Under these conditions, the period is limited by the internal delay from the flip-flop outputs through the internal feedback and logic to the flip-flop inputs. This f<sub>MAX</sub> is designated “f<sub>MAX</sub> internal”. A simple internal counter is a good example of this type of design; therefore, this parameter is sometimes called “f<sub>CNT</sub>.”

The third type of design is a simple data path application. In this case, input data is presented to the flip-flop and clocked through; no feedback is employed. Under these conditions, the period is limited by the sum of the data setup time and the data hold time (t<sub>s</sub> + t<sub>H</sub>). However, a lower limit for the period of each f<sub>MAX</sub> type is the minimum clock period (t<sub>WH</sub> + t<sub>WL</sub>). Usually, this minimum clock period determines the period for the third f<sub>MAX</sub>, designated “f<sub>MAX</sub> no feedback.”

For devices with input registers, one additional f<sub>MAX</sub> parameter is specified: f<sub>MAXIR</sub>. Because this involves no feedback, it is calculated the same way as f<sub>MAX</sub> no feedback. The minimum period will be limited either by the sum of the setup and hold times (t<sub>SIR</sub> + t<sub>HIR</sub>) or the sum of the clock widths (t<sub>WICL</sub> + t<sub>WICH</sub>). The clock widths are normally the limiting parameters, so that f<sub>MAXIR</sub> is specified as 1/(t<sub>WICL</sub> + t<sub>WICH</sub>). Note that if both input and output registers are used in the same path, the overall frequency will be limited by t<sub>ICS</sub>.

All frequencies except f<sub>MAX</sub> internal are calculated from other measured AC parameters. f<sub>MAX</sub> internal is measured directly.

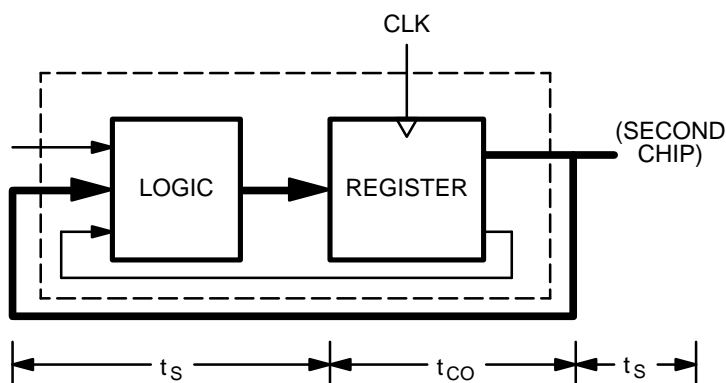

f<sub>MAX</sub> External; 1/(t<sub>s</sub> + t<sub>CO</sub>)

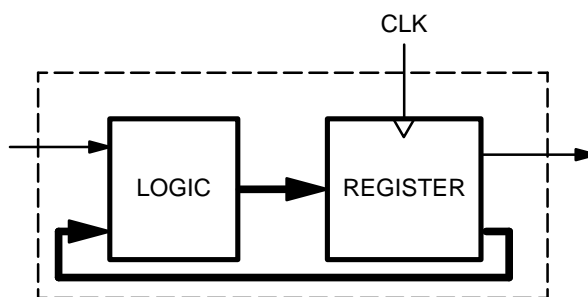

f<sub>MAX</sub> Internal (f<sub>CNT</sub>)

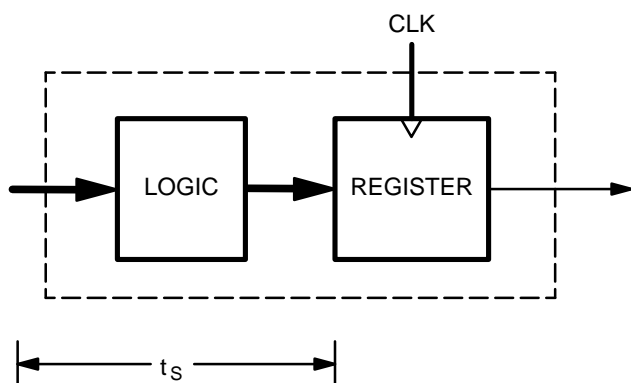

f<sub>MAX</sub> No Feedback; 1/(t<sub>s</sub> + t<sub>H</sub>) or 1/(t<sub>WH</sub> + t<sub>WL</sub>)

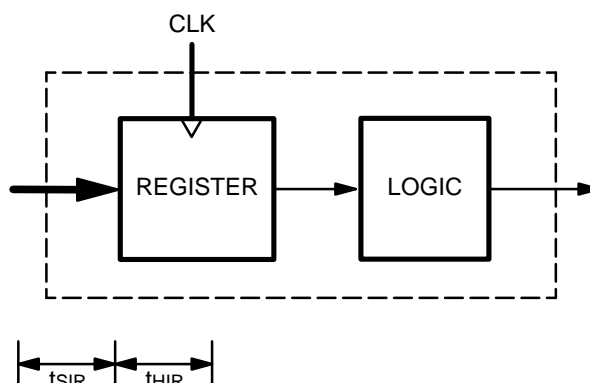

f<sub>MAXIR</sub> ; 1/(t<sub>SIR</sub> + t<sub>HIR</sub>) or 1/(t<sub>WICL</sub> + t<sub>WICH</sub>)

## ENDURANCE CHARACTERISTICS

The MACH families are manufactured using AMD's advanced Electrically Erasable process. This technology uses an EE cell to replace the fuse link used in

bipolar parts. As a result, the device can be erased and reprogrammed, a feature which allows 100% testing at the factory.

### Endurance Characteristics

Parameter Symbol	Parameter Description	Min	Units	Test Conditions
t <sub>DR</sub>	Min Pattern Data Retention Time	10	Years	Max Storage Temperature
		20	Years	Max Operating Temperature
N	Max Reprogramming Cycles	100	Cycles	Normal Programming Conditions

INPUT/OUTPUT EQUIVALENT SCHEMATICS

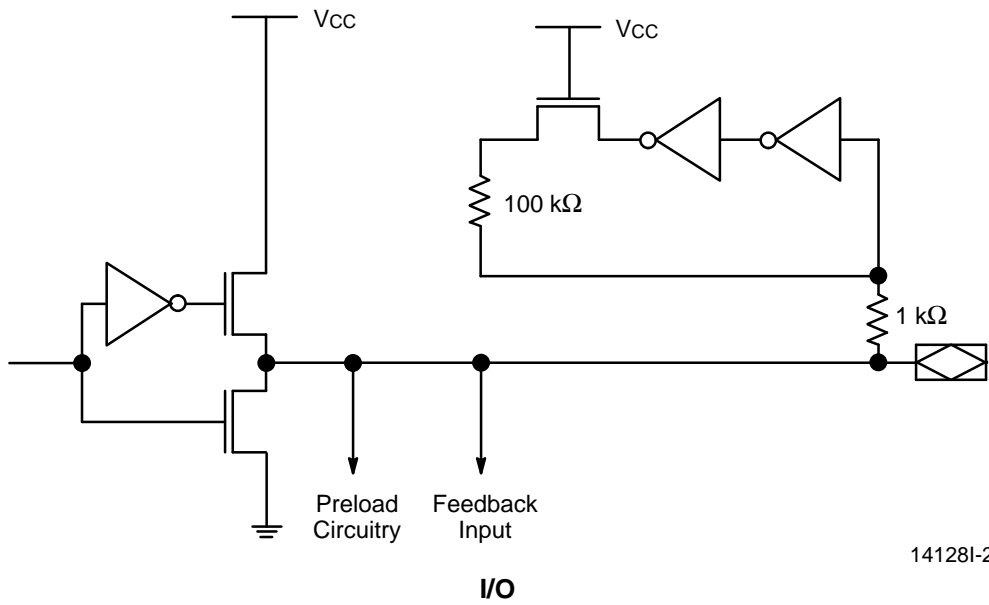
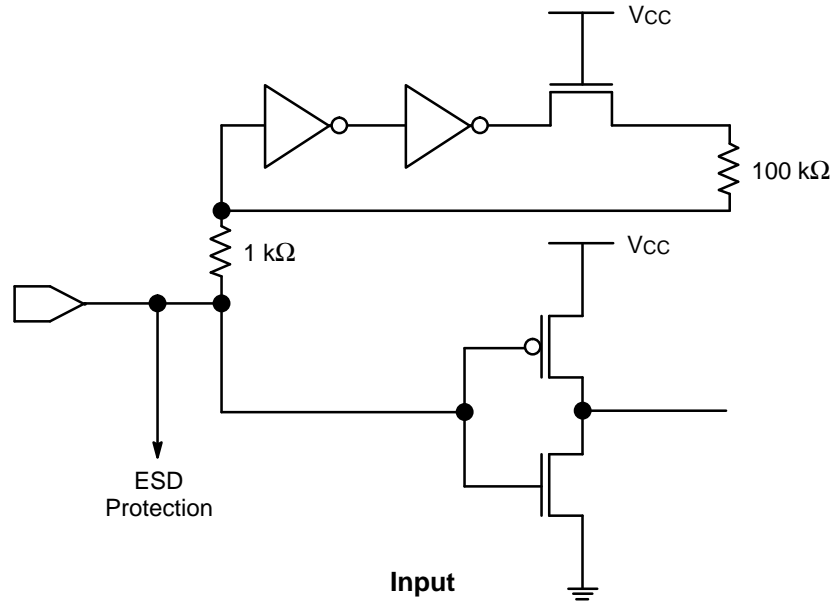

141281-25

## POWER-UP RESET

The MACH devices have been designed with the capability to reset during system power-up. Following power-up, all flip-flops will be reset to LOW. The output state will depend on the logic polarity. This feature provides extra flexibility to the designer and is especially valuable in simplifying state machine initialization. A timing diagram and parameter table are shown below. Due to the synchronous operation of the power-up reset and the

wide range of ways  $V_{CC}$  can rise to its steady state, two conditions are required to insure a valid power-up reset. These conditions are:

1. The  $V_{CC}$  rise must be monotonic.
2. Following reset, the clock input must not be driven from LOW to HIGH until all applicable input and feedback setup times are met.

Parameter Symbol	Parameter Descriptions	Max	Unit
$t_{PR}$	Power-Up Reset Time	10	$\mu s$
$t_s$	Input or Feedback Setup Time	See Switching Characteristics	
$t_{WL}$	Clock Width LOW		

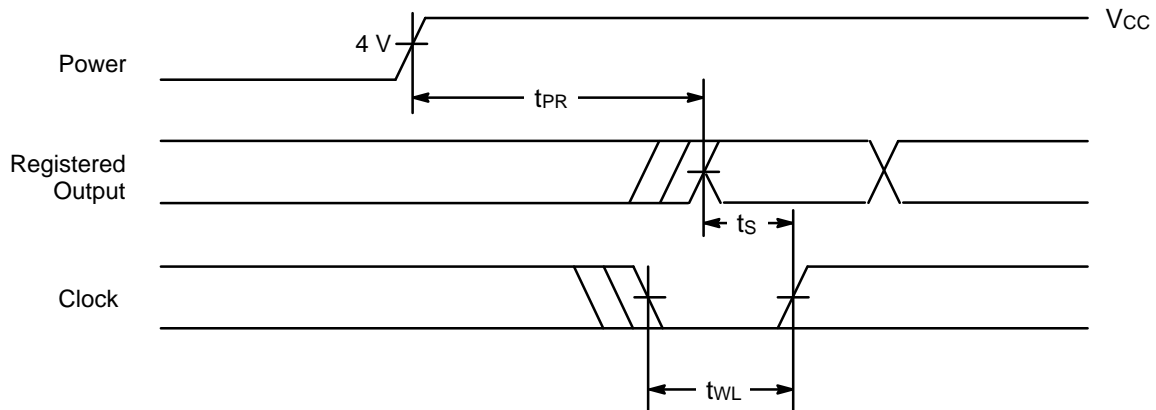

141281-26

**Power-Up Reset Waveform**

## USING PRELOAD AND OBSERVABILITY

In order to be testable, a circuit must be both controllable and observable. To achieve this, the MACH devices incorporate register preload and observability.

In preload mode, each flip-flop in the MACH device can be loaded from the I/O pins, in order to perform functional testing of complex state machines. Register preload makes it possible to run a series of tests from a known starting state, or to load illegal states and test for proper recovery. This ability to control the MACH device's internal state can shorten test sequences, since it is easier to reach the state of interest.

The observability function makes it possible to see the internal state of the buried registers during test by overriding each register's output enable and activating the output buffer. The values stored in output and buried registers can then be observed on the I/O pins. Without this feature, a thorough functional test would be impossible for any designs with buried registers.

While the implementation of the testability features is fairly straightforward, care must be taken in certain instances to insure valid testing.

One case involves asynchronous reset and preset. If the MACH registers drive asynchronous reset or preset lines and are preloaded in such a way that reset or preset are asserted, the reset or preset may remove the preloaded data. This is illustrated in Figure 2. Care should be taken when planning functional tests, so that states that will cause unexpected resets and presets are not preloaded.

Another case to be aware of arises in testing combinatorial logic. When an output is configured as combinatorial, the observability feature forces the output into registered mode. When this happens, all product terms are forced to zero, which eliminates all combinatorial data. For a straight combinatorial output, the correct value will be restored after the preload or observe function, and there will be no problem. If the function implements a combinatorial latch, however, it relies on feedback to hold the correct value, as shown in Figure 3. As this value may change during the preload or observe operation, you cannot count on the data being correct after the operation. To insure valid testing in these cases, outputs that are combinatorial latches should not be tested immediately following a preload or observe sequence, but should first be restored to a known state.

All MACH 2 devices support both preload and observability.

Contact individual programming vendors in order to verify programmer support.

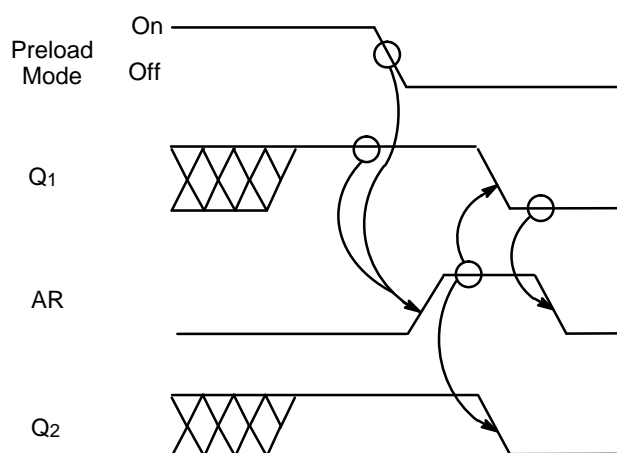
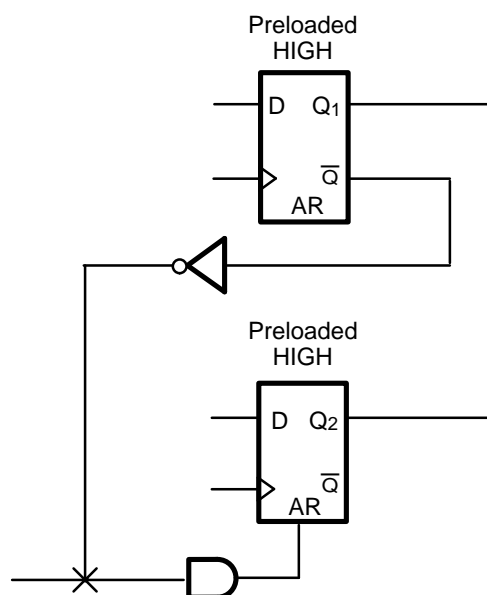

Figure 2. Preload/Reset Conflict

141281-27

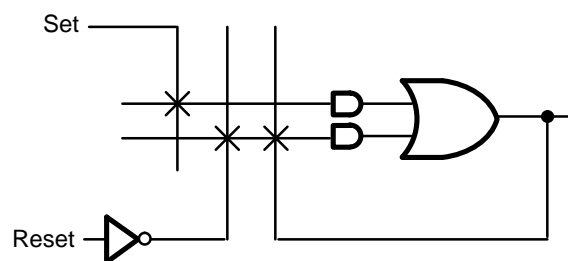

Figure 3. Combinatorial Latch

141281-28

**DEVELOPMENT SYSTEMS** (subject to change)

For more information on the products listed below, please consult the AMD FusionPLD Catalog.

<b>MANUFACTURER</b>	<b>SOFTWARE DEVELOPMENT SYSTEMS</b>
Advanced Micro Devices, Inc. P.O. Box 3453, MS 1028 Sunnyvale, CA 94088-3543 (800) 222-9323 or (408) 732-2400	MACHXL <sup>®</sup> Software  Ver. 2.0
Advanced Micro Devices, Inc. P.O. Box 3453, MS 1028 Sunnyvale, CA 94088-3543 (800) 222-9323 or (408) 732-2400	Design Center/AMD Software
Advanced Micro Devices, Inc. P.O. Box 3453, MS 1028 Sunnyvale, CA 94088-3543 (800) 222-9323 or (408) 732-2400	AMD-ABEL Software Data I/O MACH Fitters
Advanced Micro Devices, Inc. P.O. Box 3453, MS 1028 Sunnyvale, CA 94088-3543 (800) 222-9323 or (408) 732-2400	PROdeveloper/AMD Software PROsynthesis/AMD Software
Cadence Design Systems 555 River Oaks Pkwy San Jose, CA 95134 (408) 943-1234	ComposerPIC <sup>™</sup> Designer (Requires MACH Fitter)  Verilog, LeapFrog, RapidSim Simulators (Models also available from Logic Modeling)  Ver. 3.3
Capilano Computing 960 Quayside Dr., Suite 406 New Westminster, B.C. Canada V3M 6G2 (800) 444-9064 or (604) 552-6200	MacABEL <sup>™</sup> Software (Requires SmartPart MACH Fitter)
CINA, Inc. P.O. Box 4872 Mountain View, CA 94040 (415) 940-1723	SmartCAT Circuit Analyzer
Data I/O Corporation 10525 Willows Road N.E. P.O. Box 97046 Redmond, WA 98073-9746 (800) 332-8246 or (206) 881-6444	ABEL <sup>™</sup> -5 Software (Requires MACH Fitter)  Synario <sup>™</sup> Software
iNt GmbH Busenstrasse 6 D-8033 Martinsried, Munich, Germany (89) 857-6667	PLDSim 90
ISDATA GmbH Daimlerstr. 51 D7500 Karlsruhe 21 Germany Germany: 0721/75 10 87 U.S.: (510) 531-8553	LOG/iC <sup>™</sup> Software (Requires MACH Fitter)
Logic Modeling 19500 NW Gibbs Dr. P.O. Box 310 Beaverton, OR 97075 (503) 690-6900	SmartModel <sup>®</sup> Library
Logical Devices, Inc. 692 S. Military Trail Deerfield Beach, FL 33442 (800) 331-7766 or (305) 428-6868	CUPL <sup>™</sup> Software

**DEVELOPMENT SYSTEMS** (subject to change) (continued)

<b>MANUFACTURER</b>	<b>SOFTWARE DEVELOPMENT SYSTEMS</b>
Mentor Graphics Corp. 8005 S.W. Boeckman Rd. Wilsonville, OR 97070-7777 (800) 547-3000 or (503) 685-7000	PLDSynthesis™ (Requires MACH Fitter) QuickSim Simulator (Models also available from Logic Modeling)
MicroSim Corp. 20 Fairbanks Irvine, CA 92718 (714) 770-3022	Design Center Software (Requires MACH Fitter)
MINC Incorporated 6755 Earl Drive, Suite 200 Colorado Springs, CO 80918 (800) 755-FPGA or (719) 590-1155	PLDesigner™-XL Software (Requires MACH Fitter)
OrCAD 3175 N.W. Aloclek Dr. Hillsboro, OR 97124 (503) 690-9881	Programmable Logic Design Tools 386+ Schematic Design Tool 386+  Digital Simulation Tools
SUSIE-CAD 10000 Nevada Highway, Suite 201 Boulder City, NV 89005 (702) 293-2271	SUSIE™ Simulator
Teradyne EDA 321 Harrison Ave. Boston, MA 02118 (800) 777-2432 or (617) 422-2793	MultiSIM Interactive Simulator LASAR
Viewlogic Systems, Inc. 293 Boston Post Road West Marlboro, MA 01752 (800) 442-4660 or (508) 480-0881	ViewPLD or PROPLD (Requires PROSim Simulator MACH Fitter) ViewSim Simulator (Models for ViewSim also available from Logic Modeling)
<b>MANUFACTURER</b>	<b>TEST GENERATION SYSTEM</b>
Acugen Software, Inc. 427-3 Amherst St., Suite 391 Nashua, NH 03063 (603) 891-1995	ATGEN™ Test Generation Software
iNt GmbH Busenstrasse 6 D-8033 Martinsried, Munich, Germany (87) 857-6667	PLDCheck 90

Advanced Micro Devices is not responsible for any information relating to the products of third parties. The inclusion of such information is not a representation nor an endorsement by AMD of these products.

## APPROVED PROGRAMMERS (subject to change)

For more information on the products listed below, please consult the AMD FusionPLD Catalog.

MANUFACTURER	PROGRAMMER CONFIGURATION		
Advin Systems, Inc. 1050-L East Duane Ave. Sunnyvale, CA 94086 (408) 243-7000	Pilot U84		
BP Microsystems 100 N. Post Oak Rd. Houston, TX 77055-7237 (800) 225-2102 or (713) 688-4600	BP1200		
Data I/O Corporation 10525 Willows Road N.E. P.O. Box 97046 Redmond, WA 98073-9746 (800) 332-8246 or (206) 881-6444	UniSite™	Model 3900	AutoSite
Logical Devices Inc./Digelec 692 S. Military Trail Deerfield Beach, FL 33442 (800) 331-7766 or (305) 428-6868	ALLPRO™-88		
SMS North America, Inc. 16522 NE 135th Place Redmond, WA 98052 (800) 722-4122 or SMS Im Grund 15 D-7988 Vangen Im Allgau, Germany 07522-5018	Sprint/Expert		
Stag Microsystems Inc. 1600 Wyatt Dr. Suite 3 Santa Clara, CA 95054 (408) 988-1118 or Stag House Martinfield, Welwyn Garden City Herfordshire UK AL7 1JT 707-332148	Stag Quazar		
System General 510 S. Park Victoria Dr. Milpitas, CA 95035 (408) 263-6667 or 3F, No. 1, Alley 8, Lane 45 Bao Shing Rd., Shin Diau Taipei, Taiwan 2-917-3005	Turpro-1		

## APPROVED ON-BOARD PROGRAMMERS

MANUFACTURER	PROGRAMMER CONFIGURATION		
Corelis, Inc. 12607 Hidden Creek Way, Suite H Cerritos, California 70703 (310) 926-6727	JTAG PROG		
Advanced Micro Devices P.O. Box 3453, MS-1028 Sunnyvale, CA 94088-3453 (800) 222-9323	MACHpro		



**PROGRAMMER SOCKET ADAPTERS** (subject to change)

<b>MANUFACTURER</b>	<b>PART NUMBER</b>
EDI Corporation P.O. Box 366 Patterson, CA 95363 (209) 892-3270	Contact Manufacturer
Emulation Technology 2344 Walsh Ave., Bldg. F Santa Clara, CA 95051 (408) 982-0660	Contact Manufacturer
Logical Systems Corp. P.O. Box 6184 Syracuse, NY 13217-6184 (315) 478-0722	Contact Manufacturer
Procon Technologies, Inc. 1333 Lawrence Expwy, Suite 207 Santa Clara, CA 95051 (408) 246-4456	Contact Manufacturer

PHYSICAL DIMENSIONS\*

PL 044

44-Pin Plastic Leaded Chip Carrier (measured in inches)

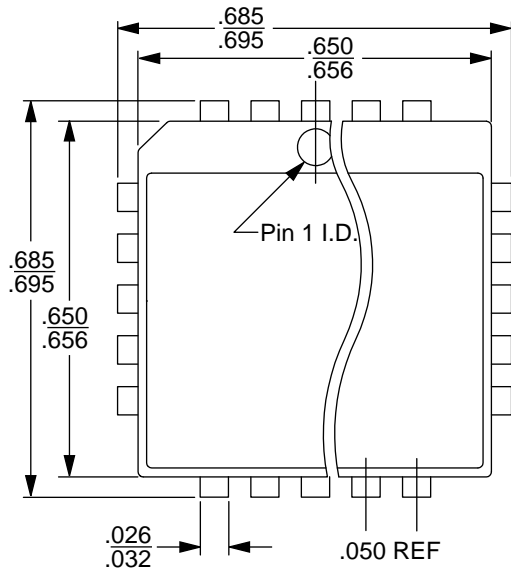

TOP VIEW

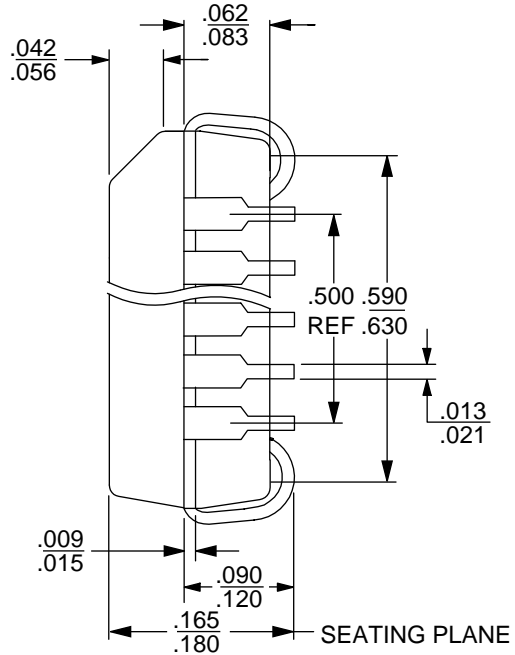

SIDE VIEW

16-038-SQ  
 PL 044  
 DA78  
 6-28-94 ae

**PHYSICAL DIMENSIONS\***

**PQT044**

**44-Pin Thin Quad Flat Pack (measured in millimeters)**

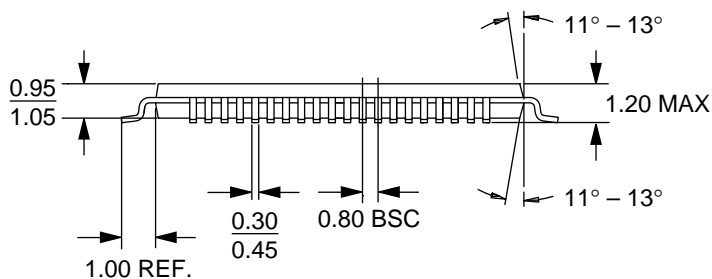
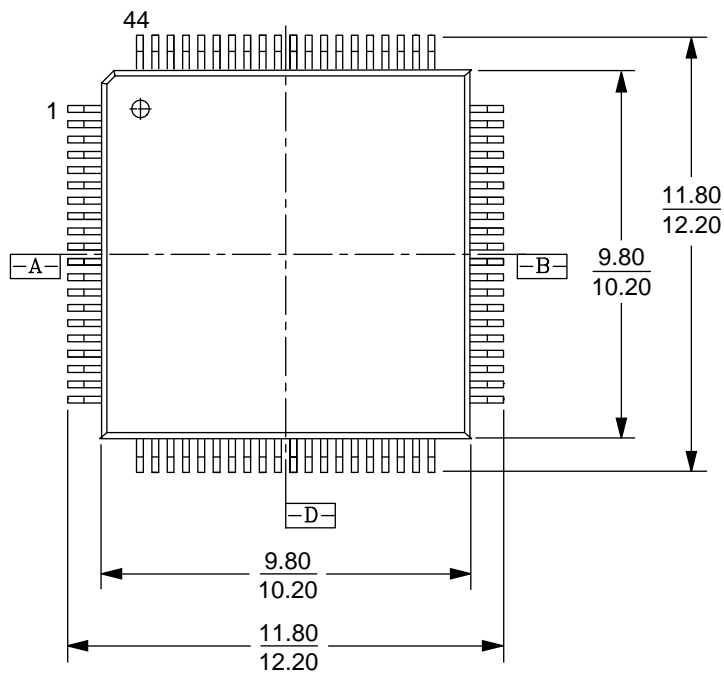

16-038-PQT-2\_AH  
PQT 44  
5-4-95 ae

\*For reference only. BSC is an ANSI standard for Basic Space Centering.

**Trademarks**

Copyright © 1995 Advanced Micro Devices, Inc. All rights reserved.

AMD, the AMD logo, MACH, and PAL are registered trademarks of Advanced Micro Devices, Inc.

Product names used in this publication are for identification purposes only and may be trademarks of their respective companies.