



82559ER Fast Ethernet PCI Controller

Networking Silicon

Datasheet

Product Features

- Optimum Integration for Lowest Cost Solution
 - Integrated IEEE 802.3 10BASE-T and 100BASE-TX compatible PHY
 - Glueless 32-bit PCI master interface
 - 128 Kbyte Flash interface
 - Thin BGA 15mm² package
 - ACPI and PCI Power Management
 - Power management event on “interesting” packets and link status change support
 - Test Access Port
- Available in extended temperature version
 - Extended temperature range: -25 C to +85 C case temperature
- High Performance Networking Functions
 - Chained memory structure similar to the 82559, 82558, 82557, and 82596
 - Improved dynamic transmit chaining with multiple priorities transmit queues
 - Full Duplex support at both 10 and 100 Mbps
 - IEEE 802.3u Auto-Negotiation support
 - 3 Kbyte transmit and 3 Kbyte receive FIFOs
 - Fast back-to-back transmission support with minimum interframe spacing
 - IEEE 802.3x 100BASE-TX Flow Control support
 - Low Power Features
 - Low power 3.3 V device
 - Efficient dynamic standby mode
 - Deep power down support
 - Clockrun protocol support

Revision History

Revision Date	Revision	Description
Mar. 1999	1.0	First release.
Mar. 2000	1.1	Modified text description of Voltage Input/Output signal in Section 3.2.3, "System and Power Management Signals".
Mar. 2001	1.3	Added information for the extended temperature version of the 82559ER silicon.

Information in this document is provided in connection with Intel products. No license, express or implied, by estoppel or otherwise, to any intellectual property rights is granted by this document. Except as provided in Intel's Terms and Conditions of Sale for such products, Intel assumes no liability whatsoever, and Intel disclaims any express or implied warranty, relating to sale and/or use of Intel products including liability or warranties relating to fitness for a particular purpose, merchantability, or infringement of any patent, copyright or other intellectual property right. Intel products are not intended for use in medical, life saving, or life sustaining applications.

Intel may make changes to specifications and product descriptions at any time, without notice.

Designers must not rely on the absence or characteristics of any features or instructions marked "reserved" or "undefined." Intel reserves these for future definition and shall have no responsibility whatsoever for conflicts or incompatibilities arising from future changes to them.

The 82559 may contain design defects or errors known as errata which may cause the product to deviate from published specifications. Current characterized errata are available on request.

Contact your local Intel sales office or your distributor to obtain the latest specifications and before placing your product order.

Copyright © Intel Corporation, 1999

* Alert on LAN is a result of the Intel-IBM Advanced Manageability Alliance and a trademark of IBM.

** Third-party brands and names are the property of their respective owners.

Contents

1.0	Introduction.....	1
1.1	82559ER Overview	1
1.2	Suggested Reading.....	1
2.0	82559ER Architectural Overview	3
2.1	Parallel Subsystem Overview.....	3
2.2	FIFO Subsystem Overview	4
2.3	10/100 Mbps Serial CSMA/CD Unit Overview	5
2.4	10/100 Mbps Physical Layer Unit.....	5
3.0	Signal Descriptions.....	7
3.1	Signal Type Definitions.....	7
3.2	PCI Bus Interface Signals	7
3.2.1	Address and Data Signals.....	7
3.2.2	Interface Control Signals	8
3.2.3	System and Power Management Signals	9
3.3	Local Memory Interface Signals	10
3.4	Testability Port Signals.....	10
3.5	PHY Signals	12
4.0	82559ER Media Access Control Functional Description.....	13
4.1	82559ER Initialization.....	13
4.1.1	Initialization Effects on 82559ER Units	13
4.2	PCI Interface	14
4.2.1	82559ER Bus Operations.....	14
4.2.2	Clockrun Signal	22
4.2.3	Power Management Event Signal	22
4.2.4	Power States	22
4.2.5	Wake-up Events	27
4.3	Parallel Flash Interface.....	28
4.4	Serial EEPROM Interface.....	28
4.5	10/100 Mbps CSMA/CD Unit.....	30
4.5.1	Full Duplex	31
4.5.2	Flow Control	31
4.5.3	Address Filtering Modifications	31
4.5.4	Long Frame Reception.....	31
4.6	Media Independent Interface (MII) Management Interface	32
5.0	82559ER Test Port Functionality.....	33
5.1	Introduction.....	33
5.2	Asynchronous Test Mode.....	33
5.3	Test Function Description.....	33
5.4	85/85	33
5.5	Tristate	33
5.6	Nand Tree	34
6.0	82559ER Physical Layer Functional Description	35
6.1	100BASE-TX PHY Unit	35

6.1.1	100BASE-TX Transmit Clock Generation	35
6.1.2	100BASE-TX Transmit Blocks	35
6.1.3	100BASE-TX Receive Blocks	38
6.1.4	100BASE-TX Collision Detection	39
6.1.5	100BASE-TX Link Integrity and Auto-Negotiation Solution	39
6.1.6	Auto 10/100 Mbps Speed Selection	39
6.2	10BASE-T Functionality	39
6.2.1	10BASE-T Transmit Clock Generation.....	39
6.2.2	10BASE-T Transmit Blocks.....	40
6.2.3	10BASE-T Receive Blocks.....	40
6.2.4	10BASE-T Collision Detection.....	41
6.2.5	10BASE-T Link Integrity	41
6.2.6	10BASE-T Jabber Control Function	41
6.2.7	10BASE-T Full Duplex	41
6.3	Auto-Negotiation Functionality	41
6.3.1	Description	42
6.3.2	Parallel Detect and Auto-Negotiation	42
6.4	LED Description	43
7.0	PCI Configuration Registers.....	45
7.1	LAN (Ethernet) PCI Configuration Space.....	45
7.1.1	PCI Vendor ID and Device ID Registers	45
7.1.2	PCI Command Register	46
7.1.3	PCI Status Register.....	47
7.1.4	PCI Revision ID Register.....	48
7.1.5	PCI Class Code Register	48
7.1.6	PCI Cache Line Size Register.....	48
7.1.7	PCI Latency Timer	49
7.1.8	PCI Header Type	49
7.1.9	PCI Base Address Registers.....	49
7.1.10	PCI Subsystem Vendor ID and Subsystem ID Registers.....	51
7.1.11	Capability Pointer	51
7.1.12	Interrupt Line Register.....	51
7.1.13	Interrupt Pin Register	52
7.1.14	Minimum Grant Register	52
7.1.15	Maximum Latency Register.....	52
7.1.16	Capability ID Register	52
7.1.17	Next Item Pointer	52
7.1.18	Power Management Capabilities Register	52
7.1.19	Power Management Control/Status Register (PMCSR).....	53
7.1.20	Data Register	54
8.0	Control/Status Registers	55
8.1	LAN (Ethernet) Control/Status Registers	55
8.1.1	System Control Block Status Word	56
8.1.2	System Control Block Command Word.....	57
8.1.3	System Control Block General Pointer.....	57
8.1.4	PORT	57
8.1.5	Flash Control Register	57
8.1.6	EEPROM Control Register.....	57

	8.1.7	Management Data Interface Control Register	57
	8.1.8	Receive Direct Memory Access Byte Count.....	58
	8.1.9	Early Receive Interrupt.....	58
	8.1.10	Flow Control Register.....	58
	8.1.11	Power Management Driver Register	58
	8.1.12	General Control Register.....	59
	8.1.13	General Status Register	59
	8.2	Statistical Counters	60
9.0		PHY Unit Registers	63
	9.1	MDI Registers 0 - 7	63
	9.1.1	Register 0: Control Register Bit Definitions	63
	9.1.2	Register 1: Status Register Bit Definitions	64
	9.1.3	Register 2: PHY Identifier Register Bit Definitions	65
	9.1.4	Register 3: PHY Identifier Register Bit Definitions	65
	9.1.5	Register 4: Auto-Negotiation Advertisement Register Bit Definitions	65
	9.1.6	Register 5: Auto-Negotiation Link Partner Ability Register Bit Definitions .	65
	9.1.7	Register 6: Auto-Negotiation Expansion Register Bit Definitions	66
	9.2	MDI Registers 8 - 15	66
	9.3	MDI Register 16 - 31	66
	9.3.1	Register 16: PHY Unit Status and Control Register Bit Definitions	66
	9.3.2	Register 17: PHY Unit Special Control Bit Definitions	67
	9.3.3	Register 18: PHY Address Register	68
	9.3.4	Register 19: 100BASE-TX Receive False Carrier Counter Bit Definitions	68
	9.3.5	Register 20: 100BASE-TX Receive Disconnect Counter Bit Definitions ...	68
	9.3.6	Register 21: 100BASE-TX Receive Error Frame Counter Bit Definitions .	68
	9.3.7	Register 22: Receive Symbol Error Counter Bit Definitions	68
	9.3.8	Register 23: 100BASE-TX Receive Premature End of Frame Error Counter Bit Definitions	69
	9.3.9	Register 24: 10BASE-T Receive End of Frame Error Counter Bit Definitions	69
	9.3.10	Register 25: 10BASE-T Transmit Jabber Detect Counter Bit Definitions ..	69
	9.3.11	Register 26: Equalizer Control and Status Bit Definitions	69
	9.3.12	Register 27: PHY Unit Special Control Bit Definitions	69
10.0		Electrical and Timing Specifications.....	71
	10.1	Absolute Maximum Ratings.....	71
	10.2	DC Specifications	71
	10.3	AC Specifications	74
	10.4	Timing Specifications	75
	10.4.1	Clocks Specifications	75
	10.4.2	Timing Parameters	76
11.0		Package and Pinout Information	83
	11.1	Package Information	83
	11.2	Pinout Information	84



11.2.1	82559ER Pin Assignments	84
11.2.2	82559ER Ball Grid Array Diagram	86

Figures

1	82559ER Block Diagram	3
2	CSR I/O Read Cycle	15
3	CSR I/O Write Cycle.....	15
4	Flash Buffer Read Cycle	16
5	Flash Buffer Write Cycle.....	17
6	PCI Retry Cycle.....	18
7	Memory Read Burst Cycle	19
8	Memory Write Burst Cycle.....	19
9	Isolate Signal Behavior to PCI Power Good Signal.....	26
10	82559ER Initialization upon PCI RST# and ISOLATE#	27
11	64 Word EEPROM Read Instruction Waveform.....	29
12	82559ER EEPROM Format	29
13	NRZ to MLT-3 Encoding Diagram	37
14	Conceptual Transmit Differential Waveform.....	37
15	Auto-Negotiation and Parallel Detect	43
16	Two and Three LED Schematic Diagram.....	44
17	PCI Configuration Registers.....	45
18	PCI Command Register	46
19	PCI Status Register	47
20	Cache Line Size Register.....	48
21	Base Address Register for Memory Mapping.....	49
22	Base Address Register for I/O Mapping.....	50
23	82559ER Control/Status Register	55
24	RBIAS100 Resistance Versus Transmitter Current	73
25	RBIAS10 Resistance Versus Transmitter Current	74
26	PCI/CardBus Clock Waveform	75
27	Output Timing Measurement Conditions.....	76
28	Input Timing Measurement Conditions.....	76
29	Flash Timings for a Read Cycle	79
30	Flash Timings for a Write Cycle	79
31	EEPROM Timings	80
32	10BASE-T NLP Timings.....	81
33	Auto-Negotiation FLP Timings	81
34	Dimension Diagram for the 82559ER 196-Pin BGA.....	83
35	82559ER Ball Grid Array Diagram	86



Note: This page left intentionally blank.

Tables

1	EEPROM Words Field Descriptions.....	30
2	4B/5B Encoder	35
3	Magnetics Modules	37
4	PCI Command Register Bits	46
5	PCI Status Register Bits.....	47
6	82559ER ID Fields Programming.....	51
7	Power Management Capability Register	52
8	Power Management Control and Status Register	53
9	Ethernet Data Register.....	54
10	Power Management Driver Register	58
11	General Control Register.....	59
12	General Status Register	59
13	82559ER Statistical Counters	60
14	General DC Specifications	71
15	PCI/CardBus Interface DC Specifications	71
16	Flash/EEPROM Interface DC Specifications.....	72
17	LED Voltage/Current Characteristics	72
18	100BASE-TX Voltage/Current Characteristics	72
19	10BASE-T Voltage/Current Characteristics	73
20	AC Specifications for PCI Signaling	74
21	PCI/CardBus Clock Specifications	75
22	X1 Clock Specifications.....	75
23	Measure and Test Condition Parameters.....	76
24	PCI Timing Parameters	77
25	Flash Timing Parameters	78
26	EEPROM Timing Parameters	80
27	10BASE-T NLP Timing Parameters	81
28	Auto-Negotiation FLP Timing Parameters.....	81
29	100Base-TX Transmitter AC Specification.....	82
30	82559ER Pin Assignments.....	84



Note: This page left intentionally blank.

1.0 Introduction

1.1 82559ER Overview

The 82559ER is part of Intel's second generation family of fully integrated 10BASE-T/100BASE-TX LAN solutions. The 82559ER consists of both the Media Access Controller (MAC) and the physical layer (PHY) combined into a single component solution. 82559 family members build on the basic functionality of the 82558 and contain power management enhancements.

The 82559ER is a 32-bit PCI controller that features enhanced scatter-gather bus mastering capabilities which enables the 82559ER to perform high-speed data transfers over the PCI bus. The 82559ER bus master capabilities enable the component to process high-level commands and perform multiple operations, thereby off-loading communication tasks from the system CPU. Two large transmit and receive FIFOs of 3 Kbytes each help prevent data underruns and overruns, allowing the 82559ER to transmit data with minimum interframe spacing (IFS).

The 82559ER can operate in either full duplex or half duplex mode. In full duplex mode the 82559ER adheres to the IEEE 802.3x Flow Control specification. Half duplex performance is enhanced by a proprietary collision reduction mechanism.

The 82559ER includes a simple PHY interface to the wire transformer at rates of 10BASE-T and 100BASE-TX, and Auto-Negotiation capability for speed, duplex, and flow control. These features and others reduce cost, real estate, and design complexity.

The 82559ER also includes an interface to a serial (4-pin) EEPROM and a parallel interface to a 128 Kbyte Flash memory. The EEPROM provides power-on initialization for hardware and software configuration parameters

1.2 Suggested Reading

The 82559 family of devices are designed to be compliant with PC industry power management initiatives. This includes the ACPI, PCI Power Management Specification, Network Device Class specification, etc. See the following publications for more information about these topics.

- PCI Specification, PCI Special Interest Group.
- Network Device Class Reference, Revision 1.0, Intel Corporation, Microsoft Corporation, and Toshiba.
- Advanced Configuration and Power Interface (ACPI) Specification, Intel Corporation, Microsoft Corporation, Toshiba.
- Advanced Power Management (APM) Specification, Intel Corporation and Microsoft Corporation.
- 82559 Fast Ethernet Multifunction PCI/CardBus Controller Datasheet, Intel Corporation.
- LAN On Motherboard (LOM) Design Guide Application Note (AP-391), Intel Corporation.
- Test Access Port Applications Note (AP-393), Intel Corporation.



Note: This page left intentionally blank.

2.0 82559ER Architectural Overview

Figure 1 is a high level block diagram of the 82559ER. It is divided into four main subsystems: a parallel subsystem, a FIFO subsystem, the 10/100 Mbps Carrier-Sense Multiple Access with Collision Detect (CSMA/CD) unit, and the 10/100 Mbps physical layer (PHY) unit.

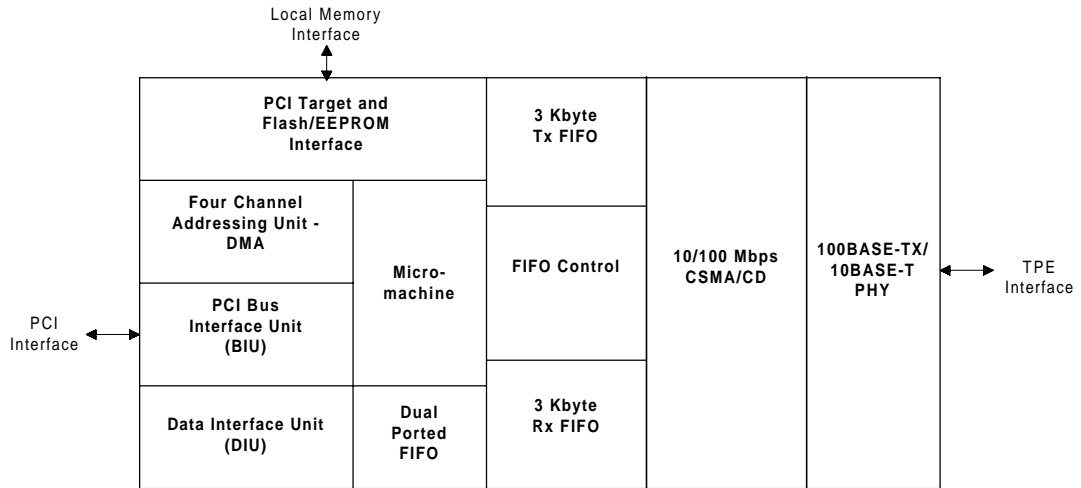

Figure 1. 82559ER Block Diagram

2.1 Parallel Subsystem Overview

The parallel subsystem is broken down into several functional blocks: a PCI bus master interface, a micromachine processing unit and its corresponding microcode ROM, and a PCI Target Control/Flash/EEPROM interface. The parallel subsystem also interfaces to the FIFO subsystem, passing data (such as transmit, receive, and configuration data) and command and status parameters between these two blocks.

The PCI bus master interface provides a complete glueless interface to a PCI bus and is compliant with the PCI Bus Specification, Revision 2.2. The 82559ER provides 32 bits of addressing and data, as well as the complete control interface to operate on a PCI bus. As a PCI target, it follows the PCI configuration format which allows all accesses to the 82559ER to be automatically mapped into free memory and I/O space upon initialization of a PCI system. For processing of transmit and receive frames, the 82559ER operates as a master on the PCI bus, initiating zero wait state transfers for accessing these data parameters.

The 82559ER Control/Status Register Block is part of the PCI target element. The Control/Status Register block consists of the following 82559ER internal control registers: System Control Block (SCB), PORT, Flash Control, EEPROM Control, and Management Data Interface (MDI) Control.

The micromachine is an embedded processing unit contained in the 82559ER. The micromachine accesses the 82559ER microcode ROM working its way through the opcodes (or instructions) contained in the ROM to perform its functions. Parameters accessed from memory such as pointers to data buffers are also used by the micromachine during the processing of transmit or receive frames by the 82559ER. A typical micromachine function is to transfer a data buffer pointer field to the 82559ER DMA unit for direct access to the data buffer. The micromachine is divided into two units, Receive Unit and Command Unit which includes transmit functions. These two units

operate independently. Control is switched between the two units according to the microcode instruction flow. The independence of the Receive and Command units in the micromachine allows the 82559ER to interleave commands and receive incoming frames, with no real-time CPU intervention.

The 82559ER contains an interface to an external Flash memory, and external serial EEPROM. These two interfaces are multiplexed. The Flash interface, which could also be used to connect to any standard 8-bit device, provides up to 128 Kbytes of addressing to the Flash. Both read and write accesses are supported. The Flash may be used for remote boot functions, network statistical and diagnostics functions, and management functions. The Flash is mapped into host system memory (anywhere within the 32-bit memory address space) for software accesses. It is also mapped into an available boot expansion ROM location during boot time of the system. More information on the Flash interface is detailed in [Section 4.3, “Parallel Flash Interface”](#). The EEPROM is used to store relevant information for a LAN connection such as node address, as well as board manufacturing and configuration information. Both read and write accesses to the EEPROM are supported by the 82559ER. Information on the EEPROM interface is detailed in [Section 4.4, “Serial EEPROM Interface”](#).

2.2 FIFO Subsystem Overview

The 82559ER FIFO subsystem consists of a 3 Kbyte transmit FIFO and 3 Kbyte receive FIFO. Each FIFO is unidirectional and independent of the other. The FIFO subsystem serves as the interface between the 82559ER parallel side and the serial CSMA/CD unit. It provides a temporary buffer storage area for frames as they are either being received or transmitted by the 82559ER, which improves performance:

- Transmit frames can be queued within the transmit FIFO, allowing back-to-back transmission within the minimum Interframe Spacing (IFS).
- The storage area in the FIFO allows the 82559ER to withstand long PCI bus latencies without losing incoming data or corrupting outgoing data.
- The 82559ER transmit FIFO threshold allows the transmit start threshold to be tuned to eliminate underruns while concurrent transmits are being performed (i.e. pending transmits will not be affected by the change in FIFO threshold).
- The FIFO subsection allows extended PCI burst accesses with zero wait states to or from the 82559ER for both transmit and receive frames. This is because such the transfer is to the FIFO storage area, rather than directly to the serial link.
- Transmissions resulting in errors (collision detection or data underrun) are retransmitted directly from the 82559ER FIFO, increasing performance and eliminating the need to re-access this data from the host system.
- Incoming runt receive frames (frames that are less than the legal minimum frame size) can be discarded automatically by the 82559ER without transferring this faulty data to the host system, and without host intervention.
- Bad Frames resolution can be selectively left to the 82559ER, or under software control.

2.3 10/100 Mbps Serial CSMA/CD Unit Overview

The CSMA/CD unit of the 82559ER allows it to be connected to either a 10 or 100 Mbps Ethernet network. The CSMA/CD unit performs all of the functions of the 802.3 protocol such as frame formatting, frame stripping, collision handling, deferral to link traffic, etc. The CSMA/CD unit can also be placed in a full-duplex mode, which allows simultaneous transmission and reception of frames.

2.4 10/100 Mbps Physical Layer Unit

The Physical Layer (PHY) unit of the 82559ER allows connection to either a 10 or 100 Mbps Ethernet network. The PHY unit supports Auto-Negotiation for 100BASE-TX Full Duplex, 100BASE-TX Half Duplex, 10BASE-T Full Duplex, and 10BASE-T Half Duplex. It also supports three LED pins to indicate link status, network activity, and speed. The 82559ER does not support external PHY devices and does not expose its internal MII bus.



Note: This page left intentionally blank.

3.0 Signal Descriptions

3.1 Signal Type Definitions

Type	Name	Description
IN	Input	The input pin is a standard input only signal.
OUT	Output	The output pin is a Totem Pole Output pin and is a standard active driver.
T/S	Tri-State	The tri-state pin is a bidirectional, input/output pin.
S/T/S	Sustained Tri-State	The sustained tri-state pin is an active low tri-state signal owned and driven by one agent at a time. The agent asserting the S/T/S pin low must drive it high at least one clock cycle before floating the pin. A new agent can only assert an S/T/S signal low one clock cycle after it has been tri-stated by the previous owner.
O/D	Open Drain	The open drain pin allows multiple devices to share this signal as a wired-OR.
A/I	Analog Input	The analog input pin is used for analog input signals.
A/O	Analog Output	The analog output pin is used for analog output signals.
B	Bias	The bias pin is an input bias.

3.2 PCI Bus Interface Signals

3.2.1 Address and Data Signals

Symbol	Type	Name and Function
AD[31:0]	T/S	Address and Data. The address and data lines are multiplexed on the same PCI pins. A bus transaction consists of an address phase followed by one or more data phases. During the address phase, the address and data lines contain the 32-bit physical address. For I/O, this is a byte address; for configuration and memory, it is a Dword address. The 82559ER uses little-endian byte ordering (in other words, AD[31:24] contain the most significant byte and AD[7:0] contain the least significant byte). During the data phases, the address and data lines contain data.
C/BE[3:0]#	T/S	Command and Byte Enable. The bus command and byte enable signals are multiplexed on the same PCI pins. During the address phase, the C/BE# lines define the bus command. During the data phase, the C/BE# lines are used as Byte Enables. The Byte Enables are valid for the entire data phase and determine which byte lanes carry meaningful data.
PAR	T/S	Parity. Parity is even across AD[31:0] and C/BE[3:0]# lines. It is stable and valid one clock after the address phase. For data phases, PAR is stable and valid one clock after either IRDY# is asserted on a write transaction or TRDY# is asserted on a read transaction. Once PAR is valid, it remains valid until one clock after the completion of the current data phase. The master drives PAR for address and write data phases; and the target, for read data phases.

3.2.2 Interface Control Signals

Symbol	Type	Name and Function
FRAME#	S/T/S	Cycle Frame. The cycle frame signal is driven by the current master to indicate the beginning and duration of a transaction. FRAME# is asserted to indicate the start of a transaction and de-asserted during the final data phase.
IRDY#	S/T/S	Initiator Ready. The initiator ready signal indicates the bus master's ability to complete the current data phase and is used in conjunction with the target ready (TRDY#) signal. A data phase is completed on any clock cycle where both IRDY# and TRDY# are sampled asserted (low) simultaneously.
TRDY#	S/T/S	Target Ready. The target ready signal indicates the selected device's ability to complete the current data phase and is used in conjunction with the initiator ready (IRDY#) signal. A data phase is completed on any clock cycle where both IRDY# and TRDY# are sampled asserted (low) simultaneously.
STOP#	S/T/S	Stop. The stop signal is driven by the target to indicate to the initiator that it wishes to stop the current transaction. As a bus slave, STOP# is driven by the 82559ER to inform the bus master to stop the current transaction. As a bus master, STOP# is received by the 82559ER to stop the current transaction.
IDSEL	IN	Initialization Device Select. The initialization device select signal is used by the 82559ER as a chip select during PCI configuration read and write transactions. This signal is provided by the host in PCI systems.
DEVSEL#	S/T/S	Device Select. The device select signal is asserted by the target once it has detected its address. As a bus master, the DEVSEL# is an input signal to the 82559ER indicating whether any device on the bus has been selected. As a bus slave, the 82559ER asserts DEVSEL# to indicate that it has decoded its address as the target of the current transaction.
REQ#	T/S	Request. The request signal indicates to the bus arbiter that the 82559ER desires use of the bus. This is a point-to-point signal and every bus master has its own REQ#.
GNT#	IN	Grant. The grant signal is asserted by the bus arbiter and indicates to the 82559ER that access to the bus has been granted. This is a point-to-point signal and every master has its own GNT#.
INTA#	O/D	Interrupt A. The interrupt A signal is used to request an interrupt by the 82559ER. This is an active low, level triggered interrupt signal.
SERR#	O/D	System Error. The system error signal is used to report address parity errors. When an error is detected, SERR# is driven low for a single PCI clock.
PERR#	S/T/S	Parity Error. The parity error signal is used to report data parity errors during all PCI transactions except a Special Cycle. The parity error pin is asserted two clock cycles after the error was detected by the device receiving data. The minimum duration of PERR# is one clock for each data phase where an error is detected. A device cannot report a parity error until it has claimed the access by asserting DEVSEL# and completed a data phase.

3.2.3 System and Power Management Signals

Symbol	Type	Name and Function
CLK	IN	Clock. The Clock signal provides the timing for all PCI transactions and is an input signal to every PCI device. The 82559ER requires a PCI Clock signal (frequency greater than or equal to 16 MHz) for nominal operation. The 82559ER supports Clock signal suspension using the Clockrun protocol.
CLKRUN#	IN/OUT O/D	Clockrun. The Clockrun signal is used by the system to pause or slow down the PCI Clock signal. It is used by the 82559ER to enable or disable suspension of the PCI Clock signal or restart of the PCI clock. When the Clockrun signal is not used, this pin should be connected to an external pull-down resistor.
RST#	IN	Reset. The PCI Reset signal is used to place PCI registers, sequencers, and signals into a consistent state. When RST# is asserted, all PCI output signals will be tri-stated.
PME#	O/D	Power Management Event. The Power Management Event signal indicates that a power management event has occurred in a PCI bus system.
ISOLATE#	IN	Isolate. The Isolate signal is used to isolate the 82559ER from the PCI bus. When Isolate is active (low), the 82559ER does not drive its PCI outputs (except PME#) or sample its PCI inputs (including CLK and RST#). If the 82559ER is not powered by an auxiliary power source, the ISOLATE# pin should be pulled high to the bus V _{cc} through a 4.7K-62K resistor.
ALTRST#	IN	Alternate Reset. The Alternate Reset signal is used to reset the 82559ER on power-up. In systems that support an auxiliary power supply, ALTRST# should be connected to a power-up detection circuit. Otherwise, ALTRST# should be tied to V _{cc} .
VIO	B IN	Voltage Input/Output. The VIO pin is the voltage bias pin for the PCI interface. In a 5 V or 3.3 V signaling environment, this pin should be connected through a 100 K Ω resistor to the voltage supply (5 V or 3.3 V, respectively). The resistor acts as a leakage current limiter in systems where the VIO bias voltage may be turned off.

3.3 Local Memory Interface Signals

Note: All unused Flash Address and Data pins must be left floating. Some of these pins have undocumented test functionality and can cause unpredictable behavior if they are unnecessarily connected to a pull-up or pull-down resistor.

Symbol	Type	Name and Function
FLD[7:0]	T/S	Flash Data Input/Output. These pins are used for Flash data interface.
FLA[16]/CLK25	OUT	Flash Address[16]/25 MHz Clock. This multiplexed pin is controlled by the status of the Flash Address[7] (FLA[7]) pin. If FLA[7] is left floating, this pin is used as FLA[16]; otherwise, if FLA[7] is connected to a pull-up resistor, this pin is used as a 25 MHz clock.
FLA[15]/EESK	OUT	Flash Address[15]/EEPROM Shift Clock. During Flash accesses, this multiplexed pin acts as the Flash Address [15] output signal. During EEPROM accesses, it acts as the serial shift clock output to the EEPROM.
FLA[14]/EEDO	IN/OUT	Flash Address[14]/EEPROM Data Output. During Flash accesses, this multiplexed pin acts as the Flash Address [14] output signal. During EEPROM accesses, it accepts serial input data from the EEPROM Data Output signal.
FLA[13]/EEDI	OUT	Flash Address[13]/EEPROM Data Input. During Flash accesses, this multiplexed pin acts as the Flash Address [13] output signal. During EEPROM accesses, it provides serial output data to the EEPROM Data Input signal.
FLA[12:8]	OUT	Flash Address[12:8]. These pins are used as Flash address outputs to support 128 Kbyte Flash addressing.
FLA[7]/CLKENB	T/S	Flash Address[7]/Clock Enable. This is a multiplexed pin and acts as the Flash Address[7] output signal during nominal operation. When the PCI RST# signal is active, this pin acts as input control over the FLA[16]/CLK25 output signal. If the FLA[7]/CLKENB pin is connected to a pull-up resistor (3.3 K Ω), a 25 MHz clock signal is provided on the FLA[16]/CLK25 output; otherwise, it is used as FLA[16] output.
FLA[6:2]	OUT	Flash Address[6:2]. These pins are used as Flash address outputs to support 128 Kbyte Flash addressing.
FLA[1]/AUXPWR	T/S	Flash Address[1]/Auxiliary Power. This multiplexed pin acts as the Flash Address[1] output signal during nominal operation. When RST is active (low), it acts as the power supply indicator. If the 82559ER is fed PCI power, this pin should be connected to the Flash Address 1 (of the Flash component) signal or left floating if Flash is not present. If the 82559ER is fed by auxiliary power, this pin should be connected to a pull-up resistor.
FLA[0]	T/S	Flash Address [0]. This pin acts as the Flash Address[0] output signal during nominal operation.
EECS	OUT	EEPROM Chip Select. The EEPROM Chip Select signal is used to assert chip select to the serial EEPROM.
FLCS#	OUT	Flash Chip Select. The Flash Chip Select signal is active during Flash.
FLOE#	OUT	Flash Output Enable. This pin provides an active low output enable control (read) to the Flash memory.
FLWE#	OUT	Flash Write Enable. This pin provides an active low write enable control to the Flash memory.

3.4 Testability Port Signals

Symbol	Type	Name and Function
TEST	IN	Test. If this input pin is high, the 82559ER will enable the test port. During nominal operation this pin should be connected to a pull-down resistor.
TCK	IN	Testability Port Clock. This pin is used for the Testability Port Clock signal.
TI	IN	Testability Port Data Input. This pin is used for the Testability Port Data Input signal.
TEEXEC	IN	Testability Port Execute Enable. This pin is used for the Testability Port Execute Enable signal.
TO	OUT	Testability Port Data Output. This pin is used for the Testability Port Data Output signal.

3.5 PHY Signals

Symbol	Type	Name and Function
X1	A/I	Crystal Input One. X1 and X2 can be driven by an external 3.3 V 25 MHz crystal. Otherwise, X1 may be driven by an external metal-oxide semiconductor (MOS) level 25 MHz oscillator when X2 is left floating.
X2	A/O	Crystal Input Two. X1 and X2 can be driven by an external 3.3 V 25 MHz crystal. Otherwise, X1 may be driven by an external MOS level 25 MHz oscillator when X2 is left floating.
TDP TDN	A/O	Analog Twisted Pair Ethernet Transmit Differential Pair. These pins transmit the serial bit stream for transmission on the Unshielded Twisted Pair (UTP) cable. The current-driven differential driver can be two-level (10BASE-T) or three-level (100BASE-TX) signals depending on the mode of operation. These signals interface directly with an isolation transformer.
RDP RDN	A/I	Analog Twisted Pair Ethernet Receive Differential Pair. These pins receive the serial bit stream from the isolation transformer. The bit stream can be two-level (10BASE-T) or three-level (100BASE-TX) signals depending on the mode of operation.
ACTLED#	OUT	Activity LED. The Activity LED pin indicates either transmit or receive activity. When activity is present, the activity LED is on; when no activity is present, the activity LED is off.
LILED#	OUT	Link Integrity LED. The Link Integrity LED pin indicates link integrity. If the link is valid in either 10 or 100 Mbps, the LED is on; if link is invalid, the LED is off.
SPEEDLED#	OUT	Speed LED. The Speed LED pin indicates the speed. The speed LED will be on at 100 Mbps and off at 10 Mbps.
RBIAS100	B	Reference Bias Resistor (100 Mbps). This pin controls the out envelope of the 82559ERER when transmitting in the 10 Mbps mode via the use of a pull-down resistor to ground. A value of 619 Ω pull-down resistor is adequate in most applications.
RBIAS10	B	Reference Bias Resistor (10 Mbps). This pin controls the out envelope of the 82559ER when transmitting in the 10 Mbps mode via the use of a pull-down resistor to ground. A value of 549 Ω pull-down resistor is adequate in most applications.
VREF	B	Voltage Reference. This pin is connected to a 1.25 V \pm 1% external voltage reference generator. To use the internal voltage reference source, this pin should be left floating.

NOTE: 619 Ω and 549 Ω for the RBIAS100 and RBIAS10, respectively, are only a recommended values and should be fine tuned for various designs.

4.0 82559ER Media Access Control Functional Description

4.1 82559ER Initialization

The 82559ER has four sources for initialization. They are listed according to their precedence:

1. ALTRST# Signal
2. PCI RST# Signal
3. Software Reset (Software Command)
4. Selective Reset (Software Command)

4.1.1 Initialization Effects on 82559ER Units

The following table shows the effect of each of the different initialization sources on major portions of the 82559ER. The initialization sources are listed in order of precedence. For example, any resource that is initialized by the Software Reset is also initialized by the D3 to D0 transition and ALTRST# and PCI RST# but not necessarily by the selective reset.

	ALTRST#	PCI RST#	ISOLATE#	D3 to D0 Transition	Software Reset	Selective Reset
EEPROM read and initialization	X	X	X	--	--	--
Loadable microcode decoded/reset	X	X	--	X	X	--
MAC configuration reset and multicast hash	X	X	X	X	X	--
Memory pointers and micro-machine state reset	X	X	--	X	X	X
PCI Configuration register reset	X	X	X	X	--	--
PHY configuration reset	X	X	--	--	--	--
Power management event reset	X	Clear only if no auxiliary power present	--	--	--	--
Statistic counters reset	X	X	--	X	X	--

4.2 PCI Interface

4.2.1 82559ER Bus Operations

After configuration, the 82559ER is ready for normal operation. As a Fast Ethernet controller, the role of the 82559ER is to access transmitted data or deposit received data. In both cases the 82559ER, as a bus master device, will initiate memory cycles via the PCI bus to fetch or deposit the required data.

To perform these actions, the 82559ER is controlled and examined by the CPU via its control and status structures and registers. Some of these control and status structures reside in the 82559ER and some reside in system memory. For access to the 82559ER's Control/Status Registers (CSR), the 82559ER acts as a slave (in other words, a target device). The 82559ER serves as a slave also while the CPU accesses its 128 Kbyte Flash buffer or its EEPROM. [Section 4.2.1.1](#) describes the 82559ER slave operation. It is followed by a description of the 82559ER operation as a bus master (initiator) in [Section 4.2.1.2, "82559ER Bus Master Operation" on page 18.](#)

4.2.1.1 82559ER Bus Slave Operation

The 82559ER serves as a target device in one of the following cases:

- CPU accesses to the 82559ER System Control Block (SCB) Control/Status Registers (CSR)
- CPU accesses to the EEPROM through its CSR
- CPU accesses to the 82559ER PORT address via the CSR
- CPU accesses to the MDI control register in the CSR
- CPU accesses to the Flash control register in the CSR
- CPU accesses to the 128 Kbyte Flash

The CSR and the Flash buffer are considered by the 82559ER as two totally separated memory spaces. The 82559ER provides separate Base Address Registers (BARs) in the configuration space to distinguish between them. The size of the CSR memory space is 4 Kbyte in the memory space and 64 bytes in the I/O space. The 82559ER treats accesses to these memory spaces differently.

4.2.1.1.1 Control/Status Register (CSR) Accesses

The 82559ER supports zero wait-state single-cycle memory or I/O-mapped accesses to its CSR space. Separate BARs request 4 Kbytes of memory space and 64 bytes of I/O space to accomplish this. Based on its needs, the software driver will use either memory or I/O mapping to access these registers. The 4 Kbytes of CSR space the 82559ER requests include the following elements:

- System Control Block (SCB) registers
- PORT register
- Flash control register
- EEPROM control register
- MDI control register
- Flow control registers

The figures below show CSR zero wait-state I/O read and write cycles. In the case of accessing the Control/Status Registers, the CPU is the initiator and the 82559ER is the target of the transaction.

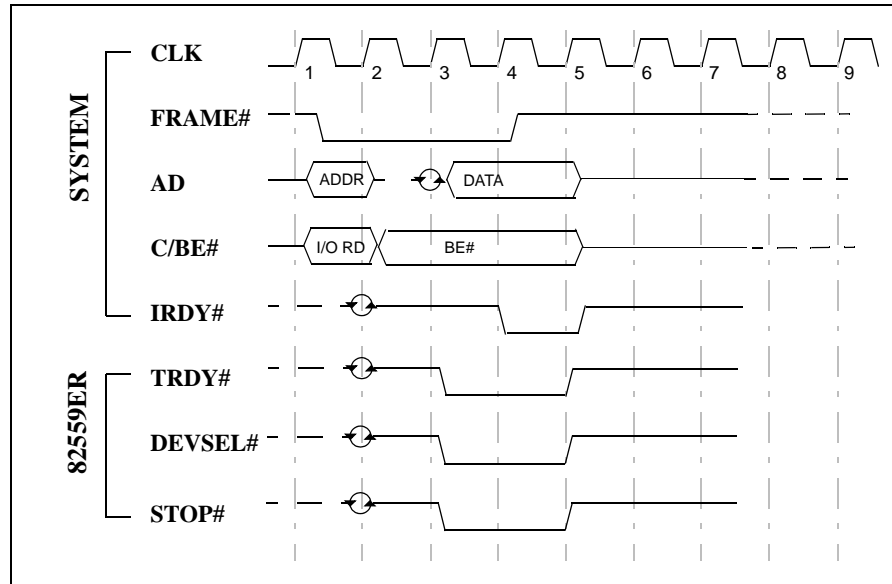

Figure 2. CSR I/O Read Cycle

Read Accesses: The CPU, as the initiator, drives address lines AD[31:0], the command and byte enable lines C/BE#[3:0] and the control lines IRDY# and FRAME#. As a slave, the 82559ER controls the TRDY# signal and provides valid data on each data access. The 82559ER allows the CPU to issue only one read cycle when it accesses the Control/Status Registers, generating a disconnect by asserting the STOP# signal. The CPU can insert wait states by de-asserting IRDY# when it is not ready.

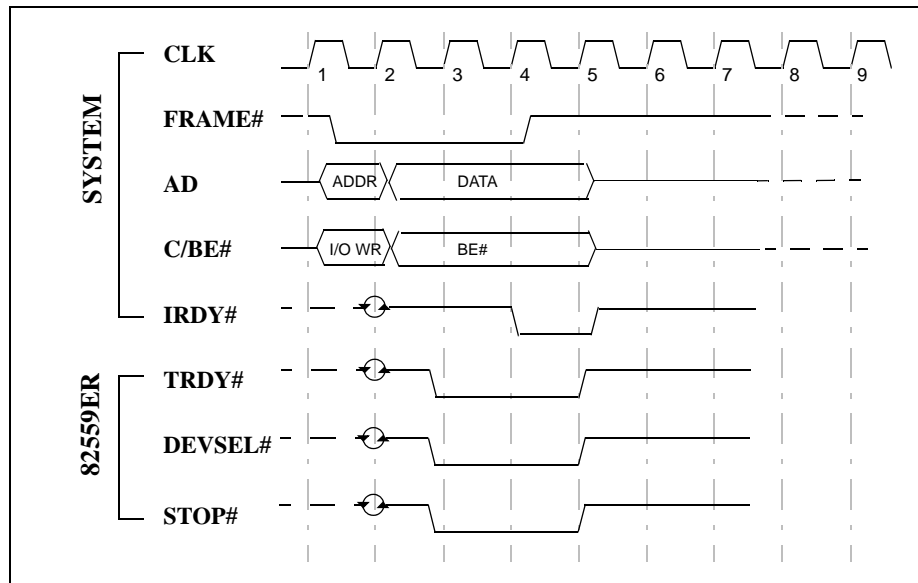

Figure 3. CSR I/O Write Cycle

Write Accesses: The CPU, as the initiator, drives the address lines AD[31:0], the command and byte enable lines C/BE#[3:0] and the control lines IRDY# and FRAME#. It also provides the 82559ER with valid data on each data access immediately after asserting IRDY#. The 82559ER

controls the TRDY# signal and asserts it from the data access. The 82559ER allows the CPU to issue only one I/O write cycle to the Control/Status Registers, generating a disconnect by asserting the STOP# signal. This is true for both memory mapped and I/O mapped accesses.

4.2.1.1.2 Flash Buffer Accesses

The CPU accesses to the Flash buffer are very slow. For this reason the 82559ER issues a target-disconnect at the first data access. The 82559ER asserts the STOP# signal to indicate a target-disconnect. The figures below illustrate memory CPU read and write accesses to the 128 Kbyte Flash buffer. The longest burst cycle to the Flash buffer contains one data access only.

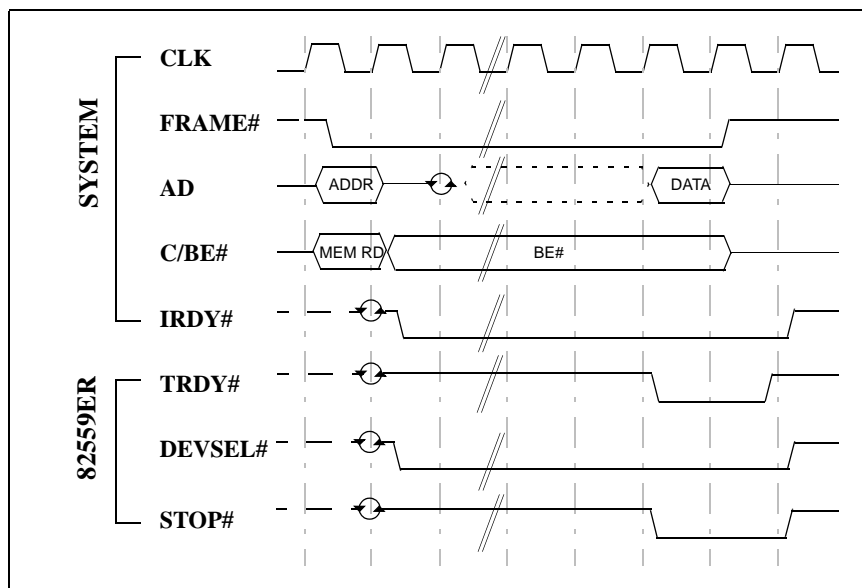

Figure 4. Flash Buffer Read Cycle

Read Accesses: The CPU, as the initiator, drives the address lines AD[31:0], the command and byte enable lines C/BE#[3:0] and the control lines IRDY# and FRAME#. The 82559ER controls the TRDY# signal and de-asserts it for a certain number of clocks until valid data can be read from the Flash buffer. When TRDY# is asserted, the 82559ER drives valid data on the AD[31:0] lines. The CPU can also insert wait states by de-asserting IRDY# until it is ready. Flash buffer read accesses can be byte or word length.

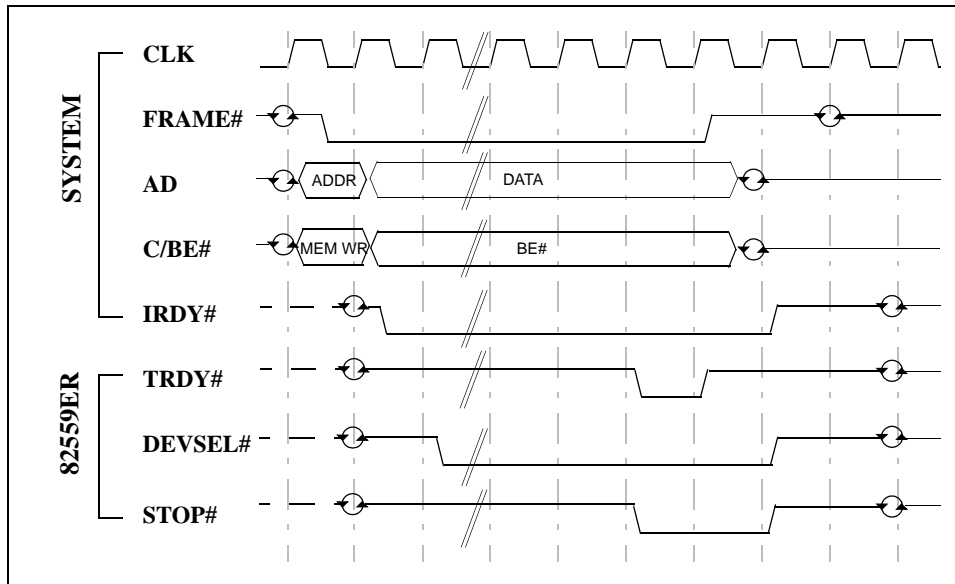

Figure 5. Flash Buffer Write Cycle

Write Accesses: The CPU, as the initiator, drives the address lines AD[31:0], the command and byte enable lines C/BE#[3:0] and the control lines IRDY# and FRAME#. It also provides the 82559ER with valid data immediately after asserting IRDY#. The 82559ER controls the TRDY# signal and de-asserts it for a certain number of clocks until valid data is written to the Flash buffer. By asserting TRDY#, the 82559ER signals the CPU that the current data access has completed. Flash buffer write accesses can be byte length only.

4.2.1.1.3 Retry Premature Accesses

The 82559ER responds with a Retry to any configuration cycle accessing the 82559ER before the completion of the automatic read of the EEPROM. The 82559ER may continue to Retry any configuration accesses until the EEPROM read is complete. The 82559ER does not enforce the rule that the retried master must attempt to access the same address again to complete any delayed transaction. Any master access to the 82559ER after the completion of the EEPROM read will be honored. [Figure 6](#) depicts the operation of a Retry cycle.

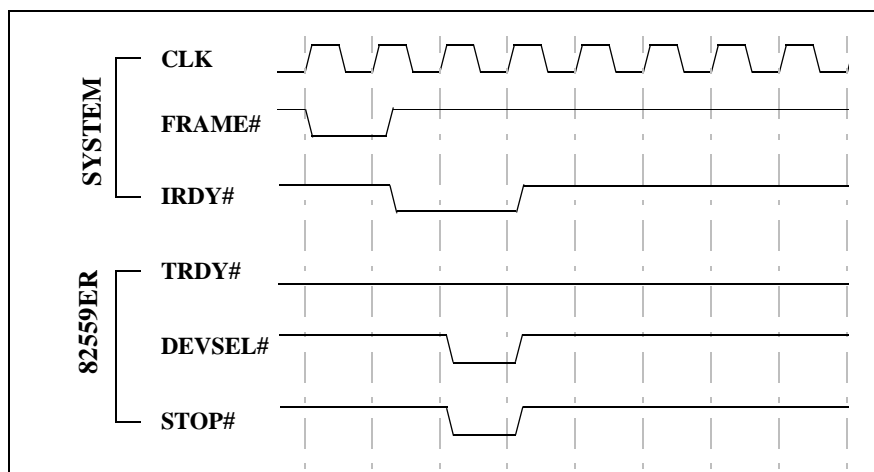

Figure 6. PCI Retry Cycle

Note: The 82559ER is considered the target in the above diagram; thus, TRDY# is not asserted.

4.2.1.1.4 Error Handling

Data Parity Errors: The 82559ER checks for data parity errors while it is the target of the transaction. If an error was detected, the 82559ER always sets the Detected Parity Error bit in the PCI Configuration Status register, bit 15. The 82559ER also asserts PERR#, if the Parity Error Response bit is set (PCI Configuration Command register, bit 6). The 82559ER does not attempt to terminate a cycle in which a parity error was detected. This gives the initiator the option of recovery.

Target-Disconnect: The 82559ER prematurely terminate a cycle in the following cases:

- After accesses to the Flash buffer
- After accesses to its CSR
- After accesses to the configuration space

System Error: The 82559ER reports parity error during the address phase using the SERR# pin. If the SERR# Enable bit in the PCI Configuration Command register or the Parity Error Response bit are not set, the 82559ER only sets the Detected Parity Error bit (PCI Configuration Status register, bit 15). If SERR# Enable and Parity Error Response bits are both set, the 82559ER sets the Signaled System Error bit (PCI Configuration Status register, bit 14) as well as the Detected Parity Error bit and asserts SERR# for one clock.

The 82559ER, when detecting system error, will claim the cycle if it was the target of the transaction and continue the transaction as if the address was correct.

Note: The 82559ER will report a system error for any parity error during an address phase, whether or not it is involved in the current transaction.

4.2.1.2 82559ER Bus Master Operation

As a PCI Bus Master, the 82559ER initiates memory cycles to fetch data for transmission or deposit received data and for accessing the memory resident control structures. The 82559ER performs zero wait state burst read and write cycles to the host main memory. [Figure 7](#) and [Figure](#)

8 depict memory read and write burst cycles. For bus master cycles, the 82559ER is the initiator and the host main memory (or the PCI host bridge, depending on the configuration of the system) is the target.

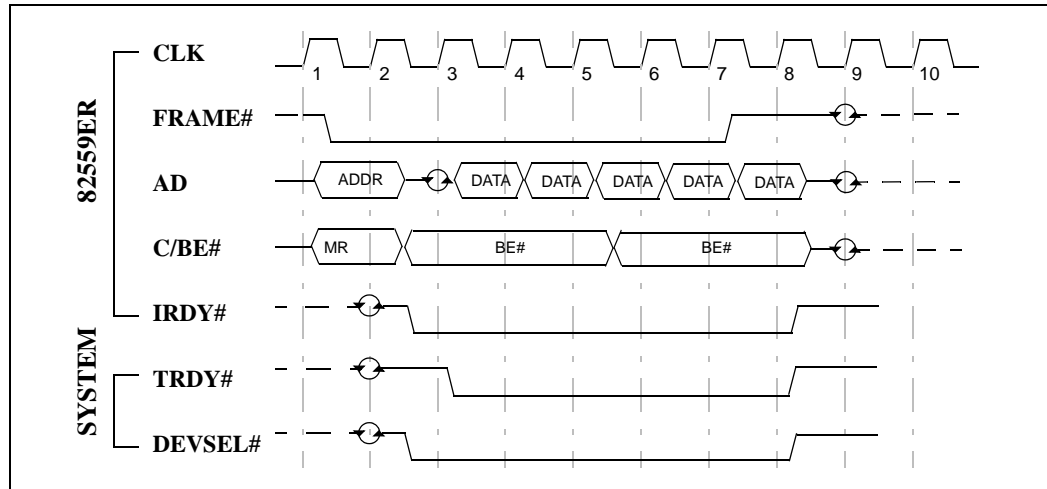

Figure 7. Memory Read Burst Cycle

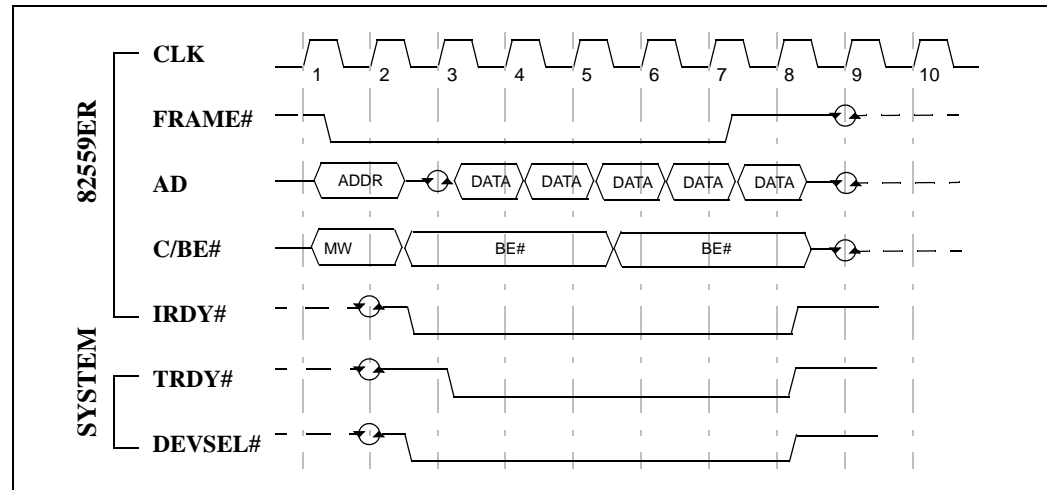

Figure 8. Memory Write Burst Cycle

The CPU provides the 82559ER with action commands and pointers to the data buffers that reside in host main memory. The 82559ER independently manages these structures and initiates burst memory cycles to transfer data to and from them. The 82559ER uses the Memory Read Multiple (MR Multiple) command for burst accesses to data buffers and the Memory Read Line (MR Line) command for burst accesses to control structures. For all write accesses to the control structure, the 82559ER uses the Memory Write (MW) command. For write accesses to data structure, the 82559ER may use either the Memory Write or Memory Write and Invalidate (MWI) commands.

Read Accesses: The 82559ER performs block transfers from host system memory to perform frame transmission on the serial link. In this case, the 82559ER initiates zero wait state memory read burst cycles for these accesses. The length of a burst is bounded by the system and the 82559ER's internal FIFO. The length of a read burst may also be bounded by the value of the

Transmit DMA Maximum Byte Count in the Configure command. The Transmit DMA Maximum Byte Count value indicates the maximum number of transmit DMA PCI cycles that will be completed after an 82559ER internal arbitration.

The 82559ER, as the initiator, drives the address lines AD[31:0], the command and byte enable lines C/BE#[3:0] and the control lines IRDY# and FRAME#. The 82559ER asserts IRDY# to support zero wait state burst cycles. The target signals the 82559ER that valid data is ready to be read by asserting the TRDY# signal.

Write Accesses: The 82559ER performs block transfers to host system memory during frame reception. In this case, the 82559ER initiates memory write burst cycles to deposit the data, usually without wait states. The length of a burst is bounded by the system and the 82559ER's internal FIFO threshold. The length of a write burst may also be bounded by the value of the Receive DMA Maximum Byte Count in the Configure command. The Receive DMA Maximum Byte Count value indicates the maximum number of receive DMA PCI transfers that will be completed before the 82559ER internal arbitration.

The 82559ER, as the initiator, drives the address lines AD[31:0], the command and byte enable lines C/BE#[3:0] and the control lines IRDY# and FRAME#. The 82559ER asserts IRDY# to support zero wait state burst cycles. The 82559ER also drives valid data on AD[31:0] lines during each data phase (from the first clock and on). The target controls the length and signals completion of a data phase by de-assertion and assertion of TRDY#.

Cycle Completion: The 82559ER completes (terminates) its initiated memory burst cycles in the following cases:

- **Normal Completion:** All transaction data has been transferred to or from the target device (for example, host main memory).
- **Backoff:** Latency Timer has expired and the bus grant signal (GNT#) was removed from the 82559ER by the arbiter, indicating that the 82559ER has been preempted by another bus master.
- **Transmit or Receive DMA Maximum Byte Count:** The 82559ER burst has reached the length specified in the Transmit or Receive DMA Maximum Byte Count field in the Configure command block.
- **Target Termination:** The target may request to terminate the transaction with a target-disconnect, target-retry, or target-abort. In the first two cases, the 82559ER initiates the cycle again. In the case of a target-abort, the 82559ER sets the Received Target-Abort bit in the PCI Configuration Status field (PCI Configuration Status register, bit 12) and does not re-initiate the cycle.
- **Master Abort:** The target of the transaction has not responded to the address initiated by the 82559ER (in other words, DEVSEL# has not been asserted). The 82559ER simply de-asserts FRAME# and IRDY# as in the case of normal completion.
- **Error Condition:** In the event of parity or any other system error detection, the 82559ER completes its current initiated transaction. Any further action taken by the 82559ER depends on the type of error and other conditions.

4.2.1.2.1 Memory Write and Invalidate

The 82559ER has four Direct Memory Access (DMA) channels. Of these four channels, the Receive DMA is used to deposit the large number of data bytes received from the link into system memory. The Receive DMA uses both the Memory Write (MW) and the Memory Write and Invalidate (MWI) commands. To use MWI, the 82559ER must guarantee the following:

1. Minimum transfer of one cache line

2. Active byte enable bits (or BE#[3:0] are all low) during MWI access
3. The 82559ER may cross the cache line boundary only if it intends to transfer the next cache line too.

To ensure the above conditions, the 82559ER may use the MWI command only if the following conditions hold:

1. The Cache Line Size (CLS) written in the CLS register during PCI configuration is 8 or 16 Dwords.
2. The accessed address is cache line aligned.
3. The 82559ER has at least 8 or 16 Dwords of data in its receive FIFO.
4. There are at least 8 or 16 Dwords of data space left in the system memory buffer.
5. The MWI Enable bit in the PCI Configuration Command register, bit 4, should be set to 1b.
6. The MWI Enable bit in the 82559ER Configure command should be set to 1b.

If any one of the above conditions does not hold, the 82559ER will use the MW command. If a MWI cycle has started and one of the conditions is no longer valid (for example, the data space in the memory buffer is now less than CLS), then the 82559ER terminates the MWI cycle at the end of the cache line. The next cycle will be either a MW or MWI cycle depending on the conditions listed above.

If the 82559ER started a MW cycle and reached a cache line boundary, it either continues or terminates the cycle depending on the Terminate Write on Cache Line configuration bit of the 82559ER Configure command (byte 3, bit 3). If this bit is set, the 82559ER terminates the MW cycle and attempts to start a new cycle. The new cycle is a MWI cycle if this bit is set and all of the above listed conditions are met. If the bit is not set, the 82559ER continues the MW cycle across the cache line boundary if required.

4.2.1.2.2 Read Align

The Read Align feature enhances the 82559ER's performance in cache line oriented systems. In these particular systems, starting a PCI transaction on a non-cache line aligned address may cause low performance.

To resolve this performance anomaly, the 82559ER attempts to terminate transmit DMA cycles on a cache line boundary and start the next transaction on a cache line aligned address. This feature is enabled when the Read Align Enable bit is set in the 82559ER Configure command (byte 3, bit 2).

If this bit is set, the 82559ER operates as follows:

- When the 82559ER is almost out of resources on the transmit DMA (that is, the transmit FIFO is almost full), it attempts to terminate the read transaction on the nearest cache line boundary when possible.
- When the arbitration counter's feature is enabled (in other words, the Transmit DMA Maximum Byte Count value is set in the Configure command), the 82559ER switches to other pending DMAs on the cache line boundary only.

Note the following:

- This feature is not recommended for use in non-cache line oriented systems since it may cause shorter bursts and lower performance.
- This feature should be used only when the CLS register in PCI Configuration space is set to 8 or 16 Dwords.

- The 82559ER reads all control data structures (including Receive Buffer Descriptors) from the first Dword (even if it is not required) to maintain cache line alignment.

4.2.1.2.3 Error Handling

Data Parity Errors: As an initiator, the 82559ER checks and detects data parity errors that occur during a transaction. If the Parity Error Response bit is set (PCI Configuration Command register, bit 6), the 82559ER also asserts PERR# and sets the Data Parity Detected bit (PCI Configuration Status register, bit 8). In addition, if the error was detected by the 82559ER during read cycles, it sets the Detected Parity Error bit (PCI Configuration Status register, bit 15).

4.2.2 Clockrun Signal

The CLKRUN# signal is used to control the PCI clock as defined in the PCI Mobile design guide and is compliant with the PCI Mobile design guide. The Clockrun signal is an open drain I/O signal. It is used as a bidirectional channel between the host and the devices.

- The host de-asserts the CLKRUN# signal to indicate that the PCI clock is about to be stopped or slowed down to a non-operational frequency.
- The host asserts the CLKRUN# signal when the interface clock is either running at a normal operating frequency or about to be started.
- The 82559ER asserts the CLKRUN# signal to indicate that it needs the PCI clock to prevent the host from stopping the PCI clock or to request that the host restore the clock if it was previously stopped.

Proper operation requires that the system latency from the nominal PCI CLK to CLKRUN# assertion should be less than 0.5 μ s. If the system latency is longer than 0.5 μ s, the occurrence of receive overruns increases. For use in these types of systems, the Clockrun functionality should be disabled (see [Section 8.1.12, “General Control Register”](#)). In this case, the 82559ER will claim the PCI clock even during idle time. If the CLKRUN# signal is not used, it should be connected to a pull-down resistor (62K Ω). The value of the resistor selected is dependent on the ND-TREE set-up used (i.e. the test fixture must be able to overdrive pull-down).

4.2.3 Power Management Event Signal

The 82559ER supports power management indications in the PCI mode. The PME# output pin provides an indication of a power management event to the system. PCI Power Management

In addition to the base functionality of the 82558 B-step, the 82559 family supports a larger set of wake-up packets and the capability to wake the system on a link status change from a low power state. The 82559ER enables the host system to be in a sleep state and remain virtually connected to the network. After a power management event or link status change is detected, the 82559ER will wake the host system. The sections below describe these events, the 82559ER power states, and estimated power consumption at each power state.

4.2.4 Power States

The 82559ER's power management register implements all four power states as defined in the Power Management Network Device Class Reference Specification, Revision 1.0. The four states, D0 through D3, vary from maximum power consumption at D0 to the minimum power consumption at D3. PCI transactions are only allowed in the D0 state, except for host accesses to the 82559ER's PCI configuration registers. The D1 and D2 power management states enable

intermediate power savings while providing the system wake-up capabilities. In the D3_{cold} state, the 82559ER can provide wake-up capabilities only if auxiliary power is supplied. Wake-up indications from the 82559ER are provided by the Power Management Event (PME#).

4.2.4.1 D0 Power State

As defined in the Network Device Class Reference Specification, the device is fully functional in the D0 power state. In this state, the 82559ER receives full power and should be providing full functionality. In the 82559ER the D0 state is partitioned into two substates, D0 Uninitialized (D0u) and D0 Active (D0a).

D0u is the 82559ER's initial power state following a PCI RST#. While in the D0u state, the 82559ER has PCI slave functionality to support its initialization by the host and supports wake up events. Initialization of the CSR, Memory, or I/O Base Address Registers in the PCI Configuration space switches the 82559ER from the D0u state to the D0a state.

In the D0a state, the 82559ER provides its full functionality and consumes its nominal power. In addition, the 82559ER supports wake on link status change (see [Section 4.2.5, “Wake-up Events” on page 27](#)). While it is active, the 82559ER requires a nominal PCI clock signal (in other words, a clock frequency greater than 16 MHz) for proper operation. During idle time, the 82559ER supports a PCI clock signal suspension using the Clockrun signal mechanism. The 82559ER supports a dynamic standby mode. In this mode, the 82559ER is able to save almost as much power as it does in the static power-down states. The transition to or from standby is done dynamically by the 82559ER and is transparent to the software.

4.2.4.2 D1 Power State

In order for a device to meet the D1 power state requirements, as specified in the Advanced Configuration and Power Interface (ACPI) Specification, Revision 1.0, it must not allow bus transmission or interrupts; however, bus reception is allowed. Therefore, device context may be lost and the 82559ER does not initiate any PCI activity. In this state, the 82559ER responds only to PCI accesses to its configuration space and system wake-up events.

The 82559ER retains link integrity and monitors the link for any wake-up events such as wake-up packets or link status change. Following a wake-up event, the 82559ER asserts the PME# signal to alert the PCI based system.

4.2.4.3 D2 Power State

The ACPI D2 power state is similar in functionality to the D1 power state. If the bus is in the B2 state, the 82559ER will consume less current than it does in the D1 state. In addition to D1 functionality, the 82559ER can provide a lower power mode with wake-on-link status change capability. The 82559ER may enter this mode if the link is down while the 82559ER is in the D2 state. In this state, the 82559ER monitors the link for a transition from an invalid link to a valid link. The 82559ER will not attempt to keep the link alive by transmitting idle symbols or link integrity pulses.¹ The sub-10 mA state due to an invalid link can be enabled or disabled by a configuration bit in the Power Management Driver Register (PMDR).

1. For a topology of two 82559ER devices connected by a crossed twisted-pair Ethernet cable, the deep power-down mode should be disabled. If it is enabled, the two devices may not detect each other if the operating system places them into a low power state before both nodes become active.

4.2.4.4 D3 Power State

In the D3 power state, the 82559ER has the same capabilities and consumes the same amount of power as it does in the D2 state. However, it enables the PCI system to be in the B3 state. If the PCI system is in the B3 state (in other words, no PCI power is present), the 82559ER provides wake-up capabilities if it is connected to an auxiliary power source in the system. If PME is disabled, the 82559ER does not provide wake-up capability or maintain link integrity. In this mode the 82559ER consumes its minimal power.

The 82559ER enables a system to be in a sub-5 watt state (low power state) and still be virtually connected. More specifically, the 82559ER supports full wake-up capabilities while it is in the D3_{cold} state. The 82559ER can be connected to an auxiliary power source (V_{AUX}), which enables it to provide wake-up functionality while the PCI power is off. The typical current consumption of the 82559ER is 125 mA at 3.3 V. Thus, a dual power plane is not required. If connected to an auxiliary power source, the 82559ER receives all of its power from the auxiliary source in all power states.

4.2.4.5 Understanding Power Requirements

When running the 82559ER off a 3.3V_{standby} power source, the actual power consumption will scale with network traffic. In other words, if the 82559ER is monitoring the network for ACPI “Interesting Packets” only the PCI bus specific circuitry will be disabled. As an example the 82559ER will typically draw approximately 120mA, in D1-D3 under a full Ethernet load. In the D0 state, the 82559ER will typically consume 125mA under the same load conditions.

The tables below summarizes the 82559ER’s functionality and power consumption at the different power states

Power State	Conditions	100 Mbs	10 Mbs
D0	Maximum	175 mA	140 mA
D0	Average (5 Mbs)	125 mA	115 mA
D0	Dynamic standby (With Network Load)	120 mA	55 mA
D2/D3 (link down)	PCI CLK	10 mA	10 mA
	w/o PCI CLK	3 mA	3 mA
Dx (x>0 with PME# disabled)	PCI CLK	10 mA	10 mA
	w/o PCI CLK	3 mA	3 mA

NOTE: All values shown for the D3 state assume the availability of 3.3 V Standby available to the device.

Power State	Link	82559ER Functionality
D0u	Don't care	<ul style="list-style-type: none"> Power-up state PCI slave access
D0a	Valid	Full functionality at full power and wake on invalid link
	Invalid	Full functionality at full power and wake on valid link
D1	Valid	<ul style="list-style-type: none"> Wake-up on "interesting" packets and link invalid PCI configuration access
	Invalid	<ul style="list-style-type: none"> Wake on link valid PCI configuration access
D2	Valid	Same functionality as D1 (link valid)
	Invalid	Detection for valid link and no link integrity
D3 (with power)	Valid	Same functionality as D1 (link valid)
	Invalid	Detection for valid link and no link integrity
Dx (x>0 without PME#)	Don't Care	No wake-up functionality

4.2.4.6 Auxiliary Power Signal

The 82559ER senses whether it is connected to the PCI power supply or to an auxiliary power supply (V_{AUX}) via the FLA1/AUXPWR pin. The auxiliary power detection pin (multiplexed with FLA1) is sampled when the PCI RST# or ALTRST# signals are active. An external pull-up resistor should be connected to the 82559ER if it is fed by V_{AUX} ; otherwise, the FLA1/AUXPWR pin should be left floating. The presence of AUXPWR affects the value reported in the Power Management Capability Register (PCI Configuration Space, offset DEH). The Power Management Capability Register is described in more detail in [Section 7.1.18, "Power Management Capabilities Register"](#).

4.2.4.7 Alternate Reset Signal

The 82559ER's ALTRST# input pin functions as a power-on reset input. Following ALTRST# being driven low, the 82559ER is initialized to a known state. In systems that support auxiliary power, this pin should be connected to the auxiliary power's power stable signal (power good) of the 82559ER's power source. In a LAN on Motherboard solution, this signal is available on the system. In network adapter implementations, an external analog device connected to the auxiliary power supply can be used to produce this signal. In systems that do not have an auxiliary power source, the ALTRST# signal should be tied to a pull-up resistor.

4.2.4.7.1 Isolate Signal

When the 82559ER is connected to V_{AUX} , it may be powered on while the PCI bus is powered off. In this case, the 82559ER isolates itself from the PCI bus. The 82559ER has a dedicated ISOLATE# pin that should be connected to the PCI power source's stable power signal (power good). Whenever the PCI Bus is in the B3 state, the PCI power good signal becomes inactive and the 82559ER isolates itself from the PCI bus. During this state, the 82559ER ignores all PCI signals including the RST# and CLK signals. It also tri-states all PCI outputs, except the PME# signal. In the transition to an active PCI power state (in other words, from B3 power state to B0 power state), the PCI power good signal shifts high.

In a LAN on Motherboard solution, the PCI power good signal is supplied by the system. In network adapter implementations, the PCI power good signal can be either generated locally using an external analog device, or connected directly to the PCI reset signal. In designs, that use both the ISOLATE# and RST# pins of the 82559ER, the PCI power good signal should envelope ISOLATE#, as shown below. For designs that use the PCI reset signal, the RST# pin on the 82559ER should be tied to the PCI power rail (through a 4.7K Ω), and the PCI reset signal should be connected to the 82559ER's ISOLATE# pin.

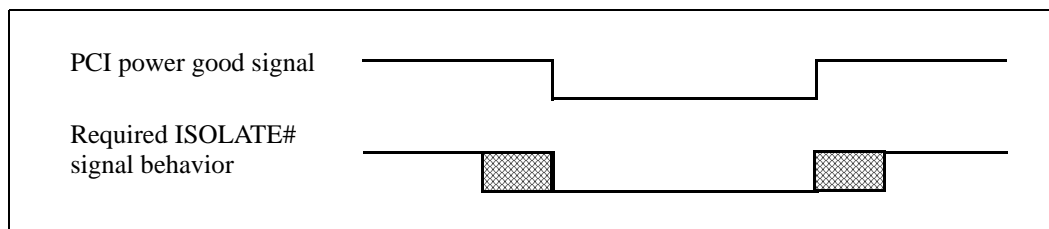

Figure 9. Isolate Signal Behavior to PCI Power Good Signal

In many systems, the PCI RST# signal is asserted low whenever the PCI bus is inactive. In these systems, the 82559ER B-step device and later devices allow the ISOLATE# pin to be driven from the PCI RST# signal. In this case, the ALTRST# pin on the 82559ER should be pulled high to the PCI bus high voltage level.

4.2.4.7.2 PCI Reset Signal

The PCI RST# signal may be activated in one of the following cases:

- Power-up
- Warm boot
- Wake-up (B3 to B0 transition)
- Set to power-down (B0 to B3 transition)

If PME is enabled (in the PCI power management registers), the RST# signal does not affect any PME related circuits (in other words, PCI power management registers, and the wake-up packet would not be affected). While the RST# signal is active, the 82559ER ignores other PCI signals and floats its outputs. However, if AUXPWR is asserted, the RST# signal has no affect on any circuitry.

While the 82559ER is in the D0, D1, or D2 power state, it is initialized by the RST# level. When the 82559ER is in the D3 power state, the system bus may be in the B3 bus power state. In the B3 power state, the PCI RST# signal is undefined; however, the auxiliary power source proposal for the PCI Specification, Revision 2.2 is for the PCI RST# signal to be an active low. Therefore, the 82559ER uses the PCI RST# similarly to the ISOLATE# signal in D3 power state. Following the trailing edge of the PCI RST#, the 82559ER is initialized while preserving the PME# signal and its context.

Note: According to the PCI specification, during the B3 state, the RST# signal is undefined.

The transition from the B3 power state to the B0 power state occurs on the trailing edge of the RST# signal.

The initialization signal is generated internally in the following cases:

- Active RST# signal while the 82559ER is the D0, D1, or D2 power state
- RST# trailing edge while the 82559ER is in the D3 power state

- ISOLATE# trailing edge

The internal initialization signal resets the PCI Configuration Space, MAC configuration, and memory structure.

The behavior of the PCI RST# signal and the internal 82559ER initialization signal are shown in the figure below.

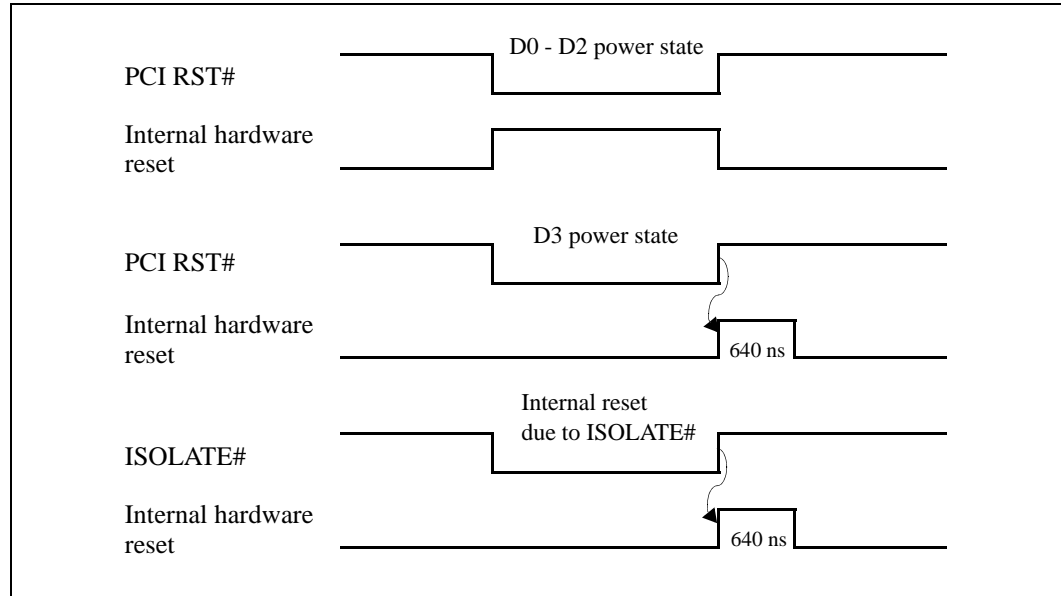

Figure 10. 82559ER Initialization upon PCI RST# and ISOLATE#

4.2.5 Wake-up Events

There are two types of wake-up events: “Interesting” Packets and Link Status Change. These two events are detailed below.

Note: The wake-up event is supported only if the PME Enable bit in the Power Management Control/Status (PMCSR) register is set. (The PMCSR is described in [Section 7.1.19, “Power Management Control/Status Register \(PMCSR\)”](#).)

4.2.5.1 “Interesting” Packet Events

In the power-down state, the 82559ER is capable of recognizing “interesting” packets. The 82559ER supports pre-defined and programmable packets that can be defined as any of the following:

- ARP Packets (with Multiple IP addresses)
- Direct Packets (with or without type qualification)
- Neighbor Discovery Multicast Address Packet (‘ARP’ in IPv6 environment)
- NetBIOS over TCP/IP (NBT) Query Packet (under IPv4)
- Internetwork Package Exchange* (IPX) Diagnostic Packet

This allows the 82559ER to handle various packet types. In general, the 82559ER supports programmable filtering of any packet in the first 128 bytes.

4.2.5.2 Link Status Change Event

The 82559ER link status indication circuit is capable of issuing a PME on a link status change from a valid link to an invalid link condition or vice versa. The 82559ER reports a PME link status event in all power states. The PME# signal is gated by the PME Enable bit in the PMCSR and the CSMA Configure command.

4.3 Parallel Flash Interface

The 82559ER's parallel interface is used primarily as a Flash interface. The 82559ER supports a glueless interface to an 8-bit wide, 128 Kbyte, parallel memory device.

The Flash (or boot PROM) is read from or written to whenever the host CPU performs a read or a write operation to a memory location that is within the Flash mapping window. All accesses to the Flash, except read accesses, require the appropriate command sequence for the device used. (Refer to the specific Flash data sheet for more details on reading from or writing to the Flash device.) The accesses to the Flash are based on a direct decode of CPU accesses to a memory window defined in either the 82559ER Flash Base Address Register (PCI Configuration space at offset 18H) or the Expansion ROM Base Address Register (PCI Configuration space at offset 30H). The 82559ER asserts control to the Flash when it decodes a valid access.

The 82559ER supports an external Flash memory (or boot PROM) of up to 128 Kbyte. The Expansion ROM BAR can be separately disabled by setting the corresponding bit in the EEPROM, word AH.

Note: Flash accesses must always be assembled or disassembled by the 82559ER whenever the access is greater than a byte-wide access. Due to slow access times to a typical Flash and to avoid violating PCI bus holding specifications (no more than 16 wait states inserted for any cycles that are not system initiation cycles), the maximum data size is either one word or one byte for a read operation and one byte only for a write operation.

4.4 Serial EEPROM Interface

The serial EEPROM stores configuration data for the 82559ER and is a serial in/serial out device. The 82559ER supports a either a 64 register or 256 register size EEPROM and automatically detects the EEPROM's size. The EEPROM should operate at a frequency of at least 1 MHz.

All accesses, either read or write, are preceded by a command instruction to the device. The address field is six bits for a 64 register EEPROM or eight bits for a 256 register EEPROM. The end of the address field is indicated by a dummy zero bit from the EEPROM, which indicates the entire address field has been transferred to the device. An EEPROM read instruction waveform is shown in the figure below.

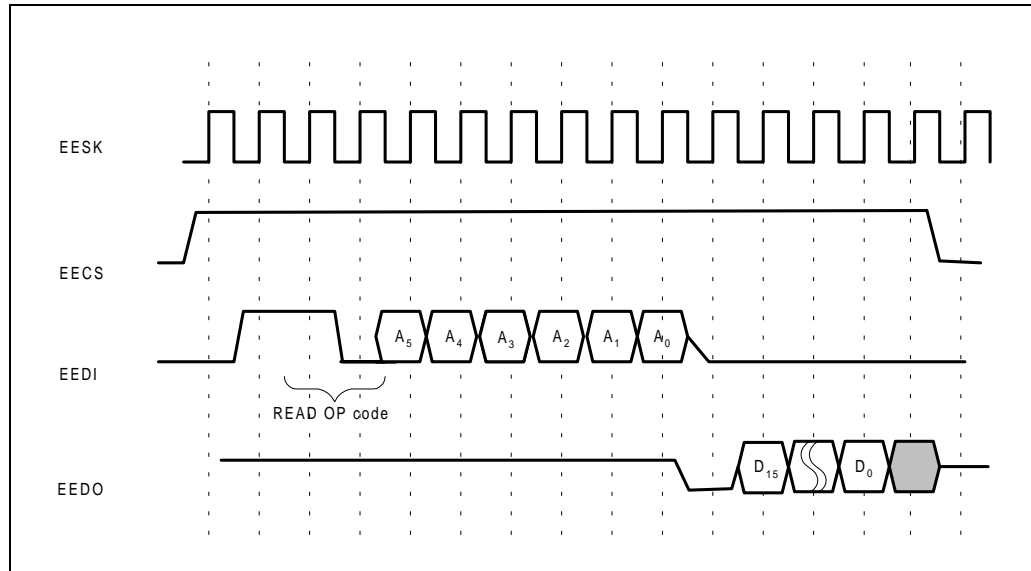

Figure 11. 64 Word EEPROM Read Instruction Waveform

The 82559ER performs an automatic read of seven words (0H, 1H, 2H, AH, Bh, Ch and DH) of the EEPROM after the de-assertion of Reset.

The 82559ER EEPROM format is shown below in [Figure 12](#).

Word	15	14	13	12	11	10	9	8	7	6	5	4	3	2	1	0
0H	IA Byte 2								IA Byte 1							
1H	IA Byte 4								IA Byte 3							
2H	IA Byte 6								IA Byte 5							
AH	Sig	ID	0b	BD	Rev ID				1b	DPD	0b	00b		0b	STB Ena	0b
BH	Subsystem ID															
CH	Subsystem Vendor ID															
DH	Reserved															

Figure 12. 82559ER EEPROM Format

Note that word 0Ah contains several configuration bits. Bits from word 0Ah, FBh through FEh, and certain bits from word 0Dh are described as follows:

Table 1. EEPROM Words Field Descriptions

Word	Bits	Name	Description
Ah	5:14	Signature	The Signature field is a signature of 01b, indicating to the 82559ER that there is a valid EEPROM present. If the Signature field is not 01b, the other bits are ignored and the default values are used.
	13	Reserved	Reserved Default value is 0b.
	12	Reserved	This bit is reserved and should be set to 0b.
	11	Boot Disable	The Boot Disable bit disables the Expansion ROM Base Address Register (PCI Configuration space, offset 30H) when it is set. Default value is 0b.
	10:8	Revision ID	These three bits are used as the three least significant bits of the device revision, if bits 15, 14, and 13 equal 011b and the ID was set as described in Section 7.1.10, "PCI Subsystem Vendor ID and Subsystem ID Registers" . The default value depends on the silicon revision.
	7	Reserved	Reserved and should be set to 0b
	6	Deep Power Down	This bit is used as the Deep Power Down enable/disable bit. When the DPD bit equals 0b, deep power down is enabled in the D3 power state while PME is disabled. If the DPD bit equals 1b, deep power down is disabled in the D3 power state while PME is disabled.
	5	Reserved	Reserved and should be set to 0b.
	4:3	Reserved	These are reserved and should be set to 00b.
	2		
	1	Standby Enable	The Standby Enable bit enables the 82559ER to enter standby mode. When this bit equals 1b, the 82559ER is able to recognize an idle state and can enter standby mode (some internal clocks are stopped for power saving purposes). The 82559ER does not require a PCI clock signal in standby mode. If this bit equals 0b, the idle recognition circuit is disabled and the 82559ER always remains in an active state. Thus, the 82559ER will always request PCI CLK using the Clockrun mechanism.
	0	Reserved	Set this bit equal to 0b for compatibility.
Dh	11:0	Reserved	Reserved.
FBh - FEh	ALL	Reserved	

Note: The IA read from the EEPROM is used by the 82559ER until an IA Setup command is issued by software. The IA defined by the IA Setup command overrides the IA read from the EEPROM.

4.5 10/100 Mbps CSMA/CD Unit

The 82559ER CSMA/CD unit implements both the IEEE 802.3 Ethernet 10 Mbps and IEEE 802.3u Fast Ethernet 100 Mbps standards. It performs all the CSMA/CD protocol functions such as transmission, reception, collision handling, etc. The 82559ER CSMA/CD unit interfaces the internal PHY unit through a standard Media Independent Interface (MII), as specified by IEEE 802.3, Chapter 22. This is a 10/100 Mbps mode in which the data stream is nibble-wide and the serial clocks run at either 25 or 2.5 MHz.

4.5.1 Full Duplex

When operating in full duplex mode the 82559ER can transmit and receive frames simultaneously. Transmission starts regardless of the state of the internal receive path. Reception starts when the internal PHY detects a valid frame on the receive differential pair of the PHY.

The 82559ER operates in either half duplex mode or full duplex mode. For proper operation, both the 82559ER CSMA/CD module and the PHY unit must be set to the same duplex mode. The CSMA duplex mode is set by the 82559ER Configure command or forced by automatically tracking the mode in the PHY unit.

The PHY duplex mode is set either by Auto-Negotiation or, if Auto-Negotiation is disabled, by setting the full duplex bit in the Management Data Interface (MDI) Register 0, bit 8. By default, the internal PHY unit advertises full duplex ability in the Auto-Negotiation process regardless of the duplex setting of the CSMA unit. The CSMA configuration should match the result of the Auto-Negotiation.

The selection of duplex operation (full or half) and flow control is done in two levels: MAC and PHY. The MAC duplex selection is done only through CSMA configuration mechanism (in other words, the Configure command from software).

4.5.2 Flow Control

The 82559ER supports IEEE 802.3x frame based flow control frames only in both full duplex and half duplex switched environments. The 82559ER flow control feature is not intended to be used in shared media environments.

Flow control is optional in full duplex mode and can be selected through software configuration. There are three modes of flow control that can be selected: frame based transmit flow control, frame based receive flow control, and none.

The PHY unit's duplex and flow control enable can be selected using NWay* Auto-Negotiation algorithm or through the Management Data Interface.

4.5.3 Address Filtering Modifications

The 82559ER can be configured to ignore one bit when checking for its Individual Address (IA) on incoming receive frames. The address bit, known as the Upper/Lower (U/L) bit, is the second least significant bit of the first byte of the IA. This bit may be used, in some cases, as a priority indication bit. When configured to do so, the 82559ER passes any frame that matches all other 47 address bits of its IA, regardless of the U/L bit value.

This configuration only affects the 82559ER specific IA and not multicast, multi-IA or broadcast address filtering. The 82559ER does not attribute any priority to frames with this bit set, it simply passes them to memory regardless of this bit.

4.5.4 Long Frame Reception

The 82559ER supports the reception of long frames, specifically frames longer than 1518 bytes, including the CRC, if software sets the Long Receive OK bit in the Configuration command. Otherwise, "long" frames are discarded.

4.6 Media Independent Interface (MII) Management Interface

The MII management interface allows the CPU to control the PHY unit via a control register in the 82559ER. This allows the software driver to place the PHY in specific modes such as full duplex, loopback, power down, etc., without the need for specific hardware pins to select the desired mode. This structure allows the 82559ER to query the PHY unit for status of the link. This register is the MDI Control Register and resides at offset 10h in the 82559ER CSR. (The MDI registers are described in detail in [Section 9.0, “PHY Unit Registers”](#).) The CPU writes commands to this register and the 82559ER reads or writes the control/status parameters to the PHY unit through the MDI register. Although the 82559ER follows the MII format, the MI bus is not accessible on external pins.

5.0 82559ER Test Port Functionality

5.1 Introduction

The 82559ER's NAND-Tree Test Access Port (TAP) is the access point for test data to and from the device. The port provides the ability to perform basic production level testing. The port provides two functions:

1. The the synchronous IC validation mode used in the production of the device. This mode gives the signals their names (i.e TCK, Testability Port Clock).
2. In addition to the synchronous test mode, the 82559ER supports asynchronous testing modes. These test modes support the validation of connections at the board level.

5.2 Asynchronous Test Mode

Four asynchronous test modes are supported for system level design use. The modes are selected through the use of Test Port input pin in static combinations. The Test Port pins are: TEST, TI, TEXEC and TCK. During normal operation the Test pin must be pulled down through a resistor (pulling Test high enables the test mode). All other Port inputs may have a pull-down at the designers discretion.

5.3 Test Function Description

The 82559 TAP mode supports several tests that can be used in board level design. These tests can help in the verification of basic functionality. As well as test the integrity of solder connection on the board. The tests are as follows:

5.4 85/85

The 85/85 test provides the same functionality to the board level designer as the Tristate mode. This mode is normal used during chip the chip burn-in cycling. The 82559ER is placed in this mode during the 85°/85% humidity test cycling. Test Pin Combinations: TEST = '1, TCK = '0, TEXEC = '1, TI = '1

5.5 Tristate

This command set all 82559ER Input and Output pins into a TRI-state (HIGH-Z) mode, all internal pull-ups and pull-downs are disabled. This mode is entered by setting the following Test Pin Combinations: TEST = '1, TCK = '0, TEXEC = '0, TI = '1, and resetting the device.

5.6 Nand Tree

The NAND tree test mode is the most useful of the asynchronous test modes. The test enables the placement of the 82559ER to be validated at board test. NAND tree was chosen for its speed advantages. Modern automated test equipment can complete a complete peripheral scan without support at the board level. This command connects all the outputs of the input-buffers in the device periphery into a NAND - tree scheme. All the output drivers of the output-buffers except the TOUT pin, are put into HIGH-Z mode. These pins can then be driven to affect the output of the tree. There are two separate chains and associated outputs for speed. Any hard strapped pins will prevent the tester from scanning correctly. This mode is enter by placing the Test Pin in the following Combinations: TEST = '1, TCK = '0, TEXEC = '1, TI = '0'.

There are two nand-tree chains with two separate outputs assigned to FLOE# (Chain 1) and FLWE# (Chain 2).

6.0 82559ER Physical Layer Functional Description

6.1 100BASE-TX PHY Unit

6.1.1 100BASE-TX Transmit Clock Generation

A 25 MHz crystal or a 25 MHz oscillator is used to drive the PHY unit's X1 and X2 pins. The PHY unit derives its internal transmit digital clocks from this crystal or oscillator input. The internal Transmit Clock signal is a derivative of the 25 MHz internal clock. The accuracy of the external crystal or oscillator must be $\pm 0.005\%$ (50 PPM).

6.1.2 100BASE-TX Transmit Blocks

The transmit subsection of the PHY unit accepts nibble-wide data from the CSMA/CD unit. The transmit subsection passes data unconditionally to the 4B/5B encoder.

The 4B/5B encoder accepts nibble-wide data (4 bits) from the CSMA unit and compiles it into 5-bit-wide parallel symbols. These symbols are scrambled and serialized into a 125 Mbps bit stream, converted by the analog transmit driver into a MLT-3 waveform format, and transmitted onto the Unshielded Twisted Pair (UTP) or Shielded Twisted Pair (STP) wire.

6.1.2.1 100BASE-TX 4B/5B Encoder

The 4B/5B encoder complies with the IEEE 802.3u 100BASE-TX standard. Four bits are encoded according to the transmit 4B/5B lookup table. The lookup table matches a 5-bit code to each 4-bit code.

The table below illustrates the 4B/5B encoding scheme associated with the given symbol.

Table 2. 4B/5B Encoder

Symbol	5B Symbol Code	4B Nibble Code
0	11110	0000
1	01001	0001
2	10100	0010
3	10101	0011
4	01010	0100
5	01011	0101
6	01110	0110
7	01111	0111
8	10010	1000
9	10011	1001
A	10110	1010
B	10111	1011
C	11010	1100
D	11011	1101

Table 2. 4B/5B Encoder

Symbol	5B Symbol Code	4B Nibble Code
E	11100	1110
F	11101	1111
I	11111	Inter Packet Idle Symbol (No 4B)
J	11000	1st Start of Packet Symbol 0101
K	10001	2nd Start of Packet Symbol 0101
T	01101	1st End of Packet Symbol
R	00111	2nd End of Packet Symbol and Flow Control
V	00000	INVALID
V	00001	INVALID
V	00010	INVALID
V	00011	INVALID
H	00100	INVALID
V	00101	INVALID
V	00110	INVALID
V	01000	INVALID
V	01100	INVALID
V	10000	PHY based Flow Control
V	11001	INVALID

6.1.2.2 100BASE-TX Scrambler and MLT-3 Encoder

Data is scrambled in 100BASE-TX to reduce electromagnetic emissions during long transmissions of high-frequency data codes. The scrambler logic accepts 5 bits from the 4B/5B encoder block and presents the scrambled data to the MLT-3 encoder. The PHY unit implements the 11-bit stream cipher scrambler as adopted by the ANSI XT3T9.5 committee for UTP operation. The cipher equation used is:

$$X[n] = X[n-11] + X[n-9] \pmod{2}$$

The encoder receives the scrambled Non-Return to Zero (NRZ) data stream from the Scrambler and encodes the stream into MLT-3 for presentation to the driver. MLT-3 is similar to NRZI coding, but three levels are output instead of two. There are three output levels: positive, negative and zero. When an NRZ “0” arrives at the input of the encoder, the last output level is maintained (either positive, negative or zero). When an NRZ “1” arrives at the input of the encoder, the output steps to the next level. The order of steps is negative-zero-positive-zero which continues periodically.

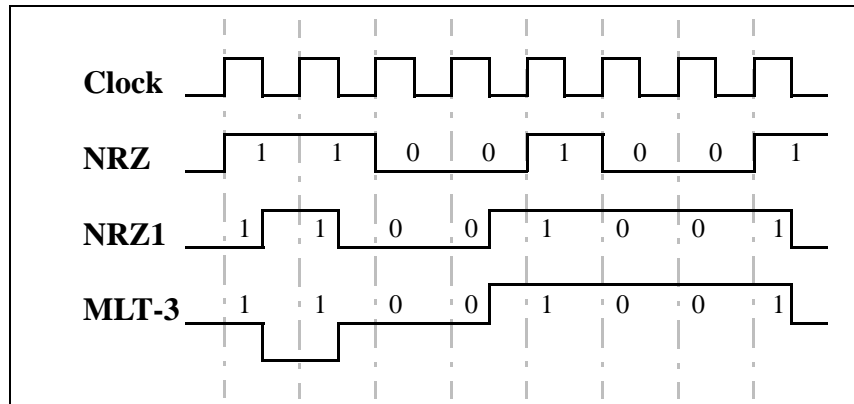

Figure 13. NRZ to MLT-3 Encoding Diagram

6.1.2.3 100BASE-TX Transmit Framing

The PHY unit does not differentiate between the fields of the MAC frame containing preamble, Start of Frame Delimiter, data and Cyclic Redundancy Check (CRC). The PHY unit encodes the first byte of the preamble as the “JK” symbol, encodes all other pieces of data according to the 4B/5B lookup table, and adds the “TR” code after the end of the packet. The PHY unit scrambles and serializes the data into a 125 Mbps stream, encodes it as MLT-3, and drives it onto the wire.

6.1.2.4 Transmit Driver

The transmit differential pair lines are implemented with a digital slope controlled current driver that meets the TP-PMD specifications. Current is sunk from the isolation transformer by the TDP and TDN pins. The conceptual transmit differential waveform for 100 Mbps is illustrated in the following figure.

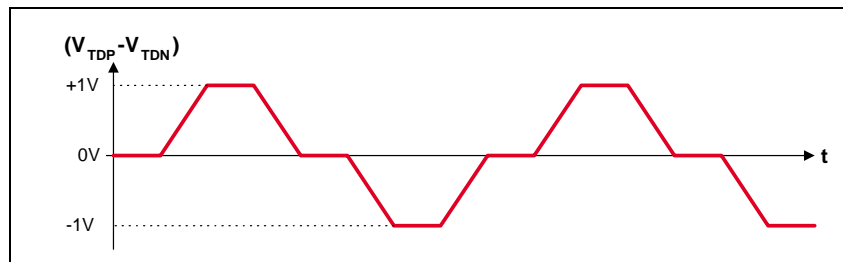

Figure 14. Conceptual Transmit Differential Waveform

The magnetics module that is external to the PHY unit converts I_{TDP} and I_{TDN} to the $2.0 V_{pp}$, as required by the TP-PMD specification. The same magnetics used for 100BASE-TX mode should also work in 10BASE-T mode. The following is a list of current magnetics modules available from several vendors:

Table 3. Magnetics Modules

Vendor	Model/Type	100BASE-TX	10BASE-T
Delta	LF8200A	Yes	Yes
Pulse Engineering	PE-68515	Yes	Yes
Pulse Engineering	H1012	Yes	Yes

6.1.3 100BASE-TX Receive Blocks

The receive subsection of the PHY unit accepts 100BASE-TX MLT-3 data on the receive differential pair. Due to the advanced digital signal processing design techniques employed, the PHY unit will accurately receive valid data from Category-5 (CAT5) UTP and Type 1 STP cable of length well in excess of 100 meters.

6.1.3.1 Adaptive Equalizer

The distorted MLT-3 signal at the end of the wire is restored by the equalizer. The equalizer performs adaptation based on the shape of the received signal, equalizing the signal to meet superior Data Dependent Jitter performance.

6.1.3.2 Receive Clock and Data Recovery

The clock recovery circuit uses advanced digital signal processing technology to compensate for various signal jitter causes. The circuit recovers the 125 MHz clock and data and presents the data to the MLT-3 decoder.

6.1.3.3 MLT-3 Decoder, Descrambler, and Receive Digital Section

The PHY unit first decodes the MLT-3 data; afterwards, the descrambler reproduces the 5B symbols originated in the transmitter. The descrambling is based on synchronization to the transmit 11-bit Linear Feedback Shift Register (LFSR) during idle. The data is decoded at the 4B/5B decoder. Once the 4B symbols are obtained, the PHY unit outputs the receive data to the CSMA unit.

6.1.3.4 100BASE-TX Receive Framing

The PHY unit does not differentiate between the fields of the MAC frame containing preamble, start of frame delimiter, data and CRC. During 100 Mbps reception, the PHY unit differentiates between the idle condition ("L" symbols on the wire) and the preamble or start of frame delimiter. When two non-consecutive bits are 0b within 10 bits (125 Mbps 5B data coding) the PHY unit immediately asserts carrier sense. When the "JK" symbols ("11000, 10001") are fully recognized, the PHY unit provides the received data to the CSMA unit. If the "JK" symbol is not recognized ("false carrier sense"), the carrier sense is immediately de-asserted and a receive error is indicated.

6.1.3.5 100BASE-TX Receive Error Detection and Reporting

In 100BASE-TX mode, the PHY unit can detect errors in receive data in a number of ways. Any of the following conditions is considered an error:

- Link integrity fails in the middle of frame reception.
- The Start of Stream Delimiter (SSD) "JK" symbol is not fully detected after idle.
- An invalid symbol is detected at the 4B/5B decoder.
- Idle is detected in the middle of a frame (before "TR" is detected).

When any of the above error conditions occurs, the PHY unit immediately asserts its receive error indication to the CSMA unit. The receive error indication is held active as long as the receive error condition persists on the receive pair.

6.1.4 100BASE-TX Collision Detection

100BASE-TX collisions in half duplex mode only are detected similarly to 10BASE-T collision detection, via simultaneous transmission and reception.

6.1.5 100BASE-TX Link Integrity and Auto-Negotiation Solution

The 82559 Auto-Negotiation function automatically configures the device to the technology, media, and speed to operate with its link partner. Auto-Negotiation is widely described in IEEE specification 802.3u, clause 28. The PHY unit supports 10BASE-T half duplex, 10BASE-T full duplex, 100BASE-TX half duplex, and 100BASE-TX full duplex.

The PHY unit has two Physical Media Attachment (PMA) technologies with its link integrity function, 10BASE-T and 100BASE-TX.

6.1.5.1 Link Integrity

In 100BASE-TX, the link integrity function is determined by a stable signal status coming from the TP-PMD block. Signal status is asserted when the PMD detects breaking squelch energy and the right bit error rate according to the ANSI specification.

6.1.5.2 Auto-Negotiation

The PHY unit fully supports IEEE 802.3u, clause 28. The technology, 10BASE-T or 100BASE-TX, is determined by the Auto-Negotiation result.

Speed and duplex auto-select are functions of Auto-Negotiation. However, these parameters may be manually configured via the MII management interface (MDI registers).

6.1.6 Auto 10/100 Mbps Speed Selection

The MAC may either allow the PHY unit to automatically select its operating speed or force the PHY into 10 Mbps or 100 Mbps mode. The Management Data Interface (MDI) can control the PHY unit speed mode.

The PHY unit auto-select function determines the operation speed of the media based on the link integrity pulses it receives. If no Fast Link Pulses (FLPs) are detected and Normal Link Pulses (NLPs) are detected, the PHY unit defaults to 10 Mbps operation. If the PHY unit detects a speed change, it dynamically changes its transmit clock and receive clock frequencies to the appropriate value. This change takes a maximum of five milliseconds.

6.2 10BASE-T Functionality

6.2.1 10BASE-T Transmit Clock Generation

The 20 MHz and 10 MHz clocks needed for 10BASE-T are synthesized from the external 25 MHz crystal or oscillator. The PHY unit provides the transmit clock and receive clock to the internal MAC at 2.5 MHz.

6.2.2 10BASE-T Transmit Blocks

6.2.2.1 10BASE-T Manchester Encoder

After the 2.5 MHz clocked data is serialized in a 10 Mbps serial stream, the 20 MHz clock performs the Manchester encoding. The Manchester code always has a mid-bit transition. If the value is 1b then the transition is from low to high. If the value is 0b then the transition is from high to low. The boundary transition occurs only when the data changes from bit to bit. For example, if the value is 10b, then the change is from high to low; if 01b, then the change is from low to high.

6.2.2.2 10BASE-T Driver and Filter

Since 10BASE-T and 100BASE-TX have different filtration needs, both filters are implemented inside the chip. This allows the two technologies to share the same magnetics. The PHY unit supports both technologies through one pair of TD pins and by externally sharing the same magnetics.

In 10 Mbps mode, the PHY unit begins transmitting the serial Manchester bit stream within 3 bit times (300 nanoseconds) after the MAC asserts TXEN. In 10 Mbps mode the line drivers use a pre-distortion algorithm to improve jitter tolerance. The line drivers reduce their drive level during the second half of “wide” (100ns) Manchester pulses and maintain a full drive level during all narrow (50ns) pulses and the first half of the wide pulses. This reduces line overcharging during wide pulses, a major source of jitter.

6.2.3 10BASE-T Receive Blocks

6.2.3.1 10BASE-T Manchester Decoder

The PHY unit performs Manchester decoding and timing recovery when in 10 Mbps mode. The Manchester-encoded data stream is decoded from the RD pair to separate Receive Clock and Receive Data from the differential signal. This data is transferred to the CSMA unit at 2.5 MHz/nibble. The high-performance circuitry of the PHY unit exceeds the IEEE 802.3 jitter requirements.

6.2.3.2 10BASE-T Twisted Pair Ethernet (TPE) Receive Buffer and Filter

In 10 Mbps mode, data is expected to be received on the receive differential pair after passing through isolation transformers. The filter is implemented inside the PHY unit for supporting single magnetics that are shared with the 100BASE-TX side. The input differential voltage range for the Twisted Pair Ethernet (TPE) receiver is greater than 585 mV and less than 3.1 V. The TPE receive buffer distinguishes valid receive data, link test pulses, and the idle condition, according to the requirements of the 10BASE-T standard.

The following line activity is determined to be inactive and is rejected:

- Differential pulses of peak magnitude less than 300 mV
- Continuous sinusoids with a differential amplitude less than $6.2 V_{pp}$ and frequency less than 2 MHz
- Sine waves of a single cycle duration starting with 0 or 180° phase that have a differential amplitude less than $6.2 V_{pp}$ and a frequency of at least 2 MHz and not more than 16 MHz. These single-cycle sine waves are discarded only if they are preceded by 4 bit times (400 nanoseconds) of silence.

All other activity is determined to be either data, link test pulses, Auto-Negotiation fast link pulses, or the idle condition. When activity is detected, the carrier sense signal is asserted to the MAC.

6.2.3.3 10BASE-T Error Detection and Reporting

In 10 Mbps mode, the PHY unit can detect errors in the receive data. The following condition is considered an error:

The receive pair's voltage level drops to the idle state during reception before the end-of-frame bit is detected (250 nanoseconds without mid-bit transitions).

6.2.4 10BASE-T Collision Detection

Collision detection in 10 Mbps mode is indicated by simultaneous transmission and reception. If the PHY unit detects this condition, it asserts a collision indication to the CSMA/CD unit.

6.2.5 10BASE-T Link Integrity

The link integrity in 10 Mbps works with link pulses. The PHY unit senses and differentiates those link pulses from fast link pulses and from 100BASE-TX idles. The 10 Mbps link pulses or normal link pulses are driven in the transmit differential pair line but are 100 ns wide and have levels from 0 V to 5 V. The link beat pulse is also used to determine if the receive pair polarity is reversed. If it is, the polarity is corrected internally.

6.2.6 10BASE-T Jabber Control Function

The PHY unit contains a jabber control function that inhibits transmission after a specified time window when enabled. In 10 Mbps mode, the jabber timer is set to a value between 26.2 ms and 39 ms. If the PHY unit detects continuous transmission that is greater than this time period, it prevents further transmissions from onto the wire until it detects that the MAC transmit enable signal has been inactive for at least 314 ms.

6.2.7 10BASE-T Full Duplex

The PHY unit supports 10 Mbps full duplex by disabling the collision function, the squelch test, and the carrier sense transmit function. This allows the PHY unit to transmit and receive simultaneously, achieving up to 20 Mbps of network bandwidth. The configuration can be achieved through Auto-Negotiation. Full duplex should only be used in point-to-point connections (no shared media).

6.3 Auto-Negotiation Functionality

The PHY unit supports Auto-Negotiation. Auto-Negotiation is an automatic configuration scheme designed to manage interoperability in multifunctional LAN environments. It allows two stations with "N" different modes of communication to establish a common mode of operation. At power-up, Auto-Negotiation automatically establishes a link that takes advantage of an Auto-Negotiation capable device. An Auto-Negotiation capable device can detect and automatically configure its port to take maximum advantage of common modes of operation without user intervention or prior knowledge by either station. The possible common modes of operation are: 100BASE-TX, 100BASE-TX Full Duplex, 10BASE-T, and 10BASE-T Full Duplex.

6.3.1 Description

Auto-Negotiation selects the fastest operating mode (in other words, the highest common denominator) available to hardware at both ends of the cable. A PHY's capability is encoded by bursts of link pulses called Fast Link Pulses (FLPs). Connection is established by FLP exchange and handshake during link initialization time. Once the link is established by this handshake, the native link pulse scheme resumes (that is, 10BASE-T or 100BASE-TX link pulses). A reset or management renegotiate command (through the MDI interface) will restart the process. To enable Auto-Negotiation, bit 12 of the MDI Control Register must be set. If the PHY unit cannot perform Auto-Negotiation, it will set this bit to a 0 and determine the speed using Parallel Detection.

The PHY unit supports four technologies: 100BASE-Tx Full and Half Duplex and 10BASE-T Full and Half Duplex. Since only one technology can be used at a time (after every re-negotiate command), a prioritization scheme must be used to ensure that the highest common denominator ability is chosen. Each bit in this table is set according to what the PHY is capable of supporting. In the case of the 82559's PHY unit, bits 0, 1, 2, 3, and 5 (10BASE-T, 10BASE-T full duplex, 100BASE-TX, 100BASE-TX full duplex and pause [frame based flow control], respectively) are set.

To detect the correct technology, the two register fields, technology ability and technology priority, should be ANDed together to obtain the highest common denominator. This value should then be used to map into a priority resolution table used by the MAC driver to use the appropriate technology.

6.3.2 Parallel Detect and Auto-Negotiation

The PHY unit automatically determines the speed of the link either by using Parallel Detect or Auto-Negotiation. Upon a reset, a link status fail, or a Negotiate/Re-negotiate command, the PHY unit inserts a long delay during which no link pulses are transmitted. This period, known as Force_Fail, insures that the PHY unit's link partner has gone into a Link Fail state before Auto-Negotiation or Parallel Detection begins. Thus, both sides (PHY unit and PHY unit's link partner)

will perform Auto-Negotiation or Parallel Detection with no data packets being transmitted. Connection is then established either by FLP exchange or Parallel Detection. The PHY unit will look for both FLPs and link integrity pulses. The following diagram illustrates this process.

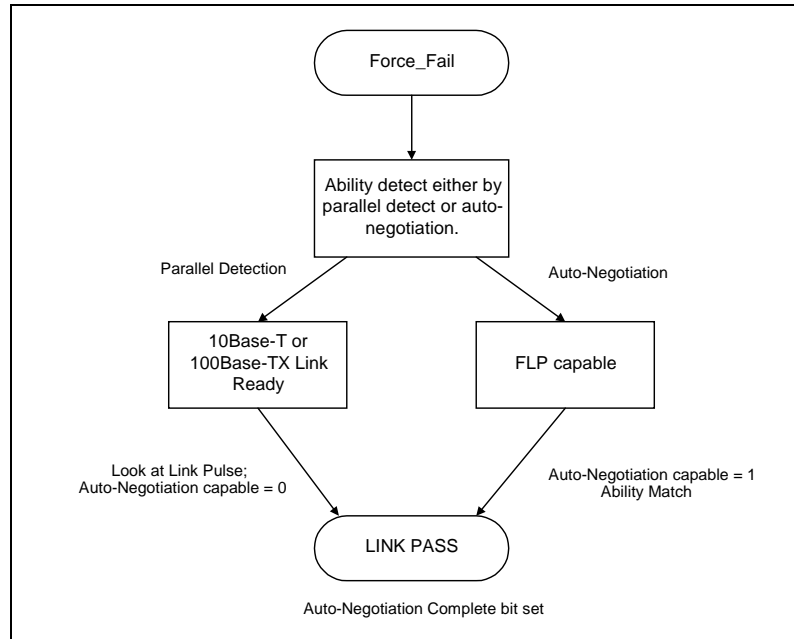

Figure 15. Auto-Negotiation and Parallel Detect

6.4 LED Description

The PHY unit supports three LED pins to indicate link status, network activity and network speed. Each pin can source 10 mA.

- **Link:** This LED is off until a valid link has been detected. After a valid link has been detected, the LED will remain on (active-low).
- **Activity:** This LED blinks on and off when activity is detected on the wire.
- **Speed:** This LED will be on if a 100BASE-TX link is detected and off if a 10BASE-T link is detected. If the link fails while in Auto-Negotiation, this LED will keep the last valid link state. If 100BASE-TX link is forced this LED will be on, regardless of the link status. This LED will be off if the 10BASE-T link is forced, regardless of the link status.

MDI register 27 in Section 9.3.12, “Register 27: PHY Unit Special Control Bit Definitions” details the information for LED function mapping and support enhancements.

Figure 16 provides possible schematic diagrams for configurations using two and three LEDs.

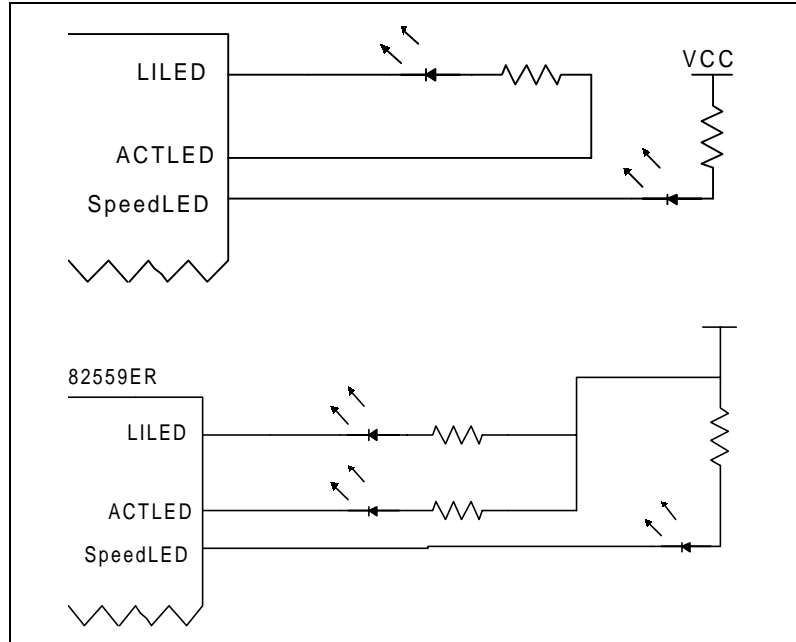

Figure 16. Two and Three LED Schematic Diagram

7.0 PCI Configuration Registers

The 82559ER acts as both a master and a slave on the PCI bus. As a master, the 82559ER interacts with the system main memory to access data for transmission or deposit received data. As a slave, some 82559ER control structures are accessed by the host CPU to read or write information to the on-chip registers. The CPU also provides the 82559ER with the necessary commands and pointers that allow it to process receive and transmit data.

7.1 LAN (Ethernet) PCI Configuration Space

The 82559ER PCI configuration space is configured as 16 Dwords of Type 0 Configuration Space Header, as defined in the PCI Specification, Revision 2.1. A small section is also configured according to its device specific configuration space. The configuration space header is depicted below in Figure 17.

Device ID		Vendor ID		00H
Status		Command		04H
Class Code			Revision ID	08H
BIST	Header Type	Latency Timer	Cache Line Size	0CH
CSR Memory Mapped Base Address Register				10H
CSR I/O Mapped Base Address Register				14H
Flash Memory Mapped Base Address Register				18H
Reserved Base Address Register				1CH
Reserved Base Address Register				20H
Reserved Base Address Register				24H
Reserved				28H
Subsystem ID		Subsystem Vendor ID		2CH
Expansion ROM Base Address Register				30H
Reserved			Cap_Ptr	34H
Reserved				38H
Max_Lat	Min_Gnt	Interrupt Pin	Interrupt Line	3CH
Power Management Capabilities		Next Item Ptr	Capability ID	DCH
Reserved	Data	Power Management CSR		E0H

Figure 17. PCI Configuration Registers

7.1.1 PCI Vendor ID and Device ID Registers

The Vendor ID and Device ID of the 82559ER are both read only word entities. Their HARD-CODED values are:

Vendor ID: 8086H

Device ID: 1209H

7.1.2 PCI Command Register

The 82559ER Command register at word address 04h in the PCI configuration space provides control over the 82559ER's ability to generate and respond to PCI cycles. If a 0H is written to this register, the 82559ER is logically disconnected from the PCI bus for all accesses except configuration accesses. The format of this register is shown in the figure below.

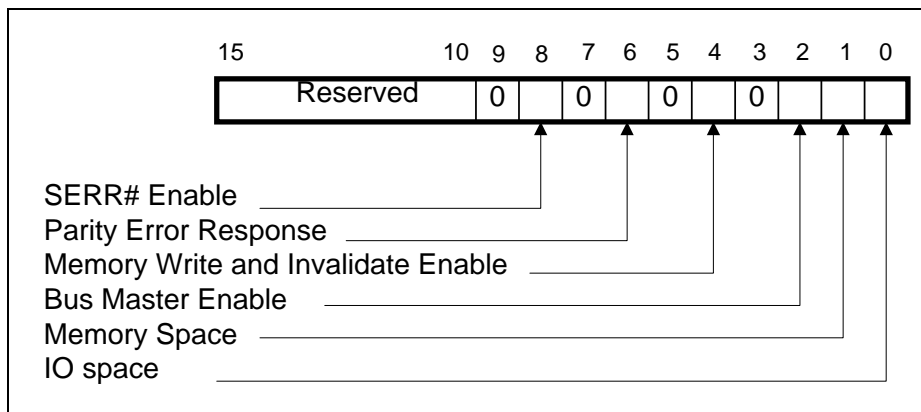

Figure 18. PCI Command Register

Note that bits three, five, seven, and nine are set to 0b. The table below describes the bits of the PCI Command register.

Table 4. PCI Command Register Bits

Bits	Name	Description
15:10	Reserved	These bits are reserved and should be set to 000000b.
8	SERR# Enable	This bit controls a device's ability to enable the SERR# driver. A value of 0b disables the SERR# driver. A value of 1b enables the SERR# driver. This bit must be set to report address parity errors. In the 82559ER, this bit is configurable and has a default value of 0b.
6	Parity Error Control	This bit controls a device's response to parity errors. A value of 0b causes the device to ignore any parity errors that it detects and continue normal operation. A value of 1b causes the device to take normal action when a parity error is detected. This bit must be set to 0b after RST# is asserted. In the 82559ER, this bit is configurable and has a default value of 0b.
4	Memory Write and Invalidate Enable	This bit controls a device's ability to use the Memory Write and Invalidate command. A value of 0b disables the device from using the Memory Write and Invalidate Enable command. A value of 1b enables the device to use the Memory Write and Invalidate command. In the 82559ER, this bit is configurable and has a default value of 0b.
2	Bus Master	This bit controls a device's ability to act as a master on the PCI bus. A value of 0b disables the device from generating PCI accesses. A value of 1b allows the device to behave as a bus master. In the 82559ER, this bit is configurable and has a default value of 0b.
1	Memory Space	This bit controls a device's response to the memory space accesses. A value of 0b disables the device response. A value of 1b allows the device to respond to memory space accesses. In the 82559ER, this bit is configurable and its default value of 0b.
0	I/O Space	This bit controls a device's response to the I/O space accesses. A value of 0b disables the device response. A value of 1b allows the device to respond to I/O space accesses. In the 82559ER, this bit is configurable and the default value of 0b.

7.1.3 PCI Status Register

The 82559ER Status register is used to record status information for PCI bus related events. The format of this register is shown in the figure below.

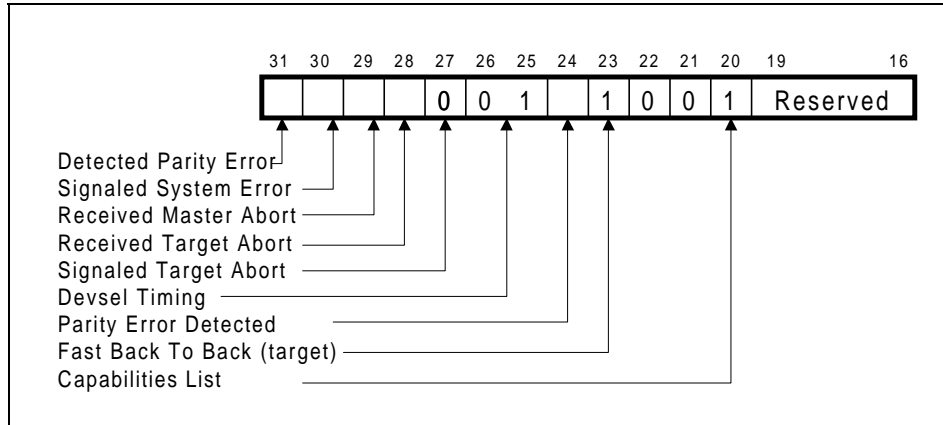

Figure 19. PCI Status Register

Note that bits 21, 22, 26, and 27 are set to 0b and bits 20, 23, and 25 are set to 1b. The PCI Status register bits are described in the table below.

Table 5. PCI Status Register Bits

Bits	Name	Description
31	Detected Parity Error	This bit indicates whether a parity error is detected. This bit must be asserted by the device when it detects a parity error, even if parity error handling is disabled (as controlled by the Parity Error Response bit in the PCI Command register, bit 6). In the 82559ER, the initial value of the Detected Parity Error bit is 0b. This bit is set until cleared by writing a 1b.
30	Signaled System Error	This bit indicates when the device has asserted SERR#. In the 82559ER, the initial value of the Signaled System Error bit is 0b. This bit is set until cleared by writing a 1b.
29	Received Master Abort	This bit indicates whether or not a master abort has occurred. This bit must be set by the master device when its transaction is terminated with a master abort. In the 82559ER, the initial value of the Received Master Abort bit is 0b. This bit is set until cleared by writing a 1b.
28	Received Target Abort	This bit indicates that the master has received the target abort. This bit must be set by the master device when its transaction is terminated by a target abort. In the 82559ER, the initial value of the Received Target Abort bit is 0b. This bit is set until cleared by writing a 1b.
27	Signaled Target Abort	This bit indicates whether a transaction was terminated by a target abort. This bit must be set by the target device when it terminates a transaction with target abort. In the 82559ER, this bit is always set to 0b.
26:25	DEVSEL# Timing	These two bits indicate the timing of DEVSEL#: 00b - Fast 01b - Medium 10b - Slow 11b - Reserved In the 82559ER, these bits are always set to 01b, medium.

Table 5. PCI Status Register Bits

Bits	Name	Description
24	Parity Error Detected	This bit indicates whether a parity error has been detected. This bit is set to 1b when the following three conditions are met: <ol style="list-style-type: none"> 1. The bus agent asserted PERR# itself or observed PERR# asserted. 2. The agent setting the bit acted as the bus master for the operation in which the error occurred. 3. The Parity Error Response bit in the command register (bit 6) is set. In the 82559ER, the initial value of the Parity Error Detected bit is 0b. This bit is set until cleared by writing a 1b.
23	Fast Back-to-Back	This bit indicates a device's ability to accept fast back-to-back transactions when the transactions are not to the same agent. A value of 0b disables fast back-to-back ability. A value of 1b enables fast back-to-back ability. In the 82559ER, this bit is read only and is set to 1b.
20	Capabilities List	This bit indicates whether the 82559ER implements a list of new capabilities such as PCI Power Management. A value of 0b means that this function does not implement the Capabilities List. If this bit is set to 1b, the Cap_Ptr register provides an offset into the 82559ER PCI Configuration space pointing to the location of the first item in the Capabilities List. This bit is set only if the power management bit in the EEPROM is set.
19:16	Reserved	These bits are reserved and should be set to 0000b.

7.1.4 PCI Revision ID Register

The Revision ID is an 8-bit read only register with a default value of 08h for the 82559ER. The three least significant bits of the Revision ID can be overridden by the ID and Revision ID fields in the EEPROM (Section 4.4, “Serial EEPROM Interface”).

7.1.5 PCI Class Code Register

The Class Code register is read only and is used to identify the generic function of the device and, in some cases, specific register level programming interface. The register is broken into three byte size fields. The upper byte is a base class code and specifies the 82559ER as a network controller, 2H. The middle byte is a subclass code and specifies the 82559ER as an Ethernet controller, 0H. The lower byte identifies a specific register level programming interface and the 82559ER always returns a 0h in this field.

7.1.6 PCI Cache Line Size Register

In order for the 82559ER to support the Memory Write and Invalidate (MWI) command, the 82559ER must also support the Cache Line Size (CLS) register in PCI Configuration space. The register supports only cache line sizes of 8 and 16 Dwords. Any value other than 8 or 16 that is written to the register is ignored and the 82559ER does not use the MWI command. If a value other than 8 or 16 is written into the CLS register, the 82559ER returns all zeroes when the CLS register is read. The figure below illustrates the format of this register.

7	6	5	4	3	2	1	0
0	0	0	RW	RW	0	0	0

Figure 20. Cache Line Size Register

Note: Bit 3 is set to 1b only if the value 00001000b (8H) is written to this register, and bit 4 is set to 1b only if the value of 00010000b (16H) is written to this register. All other bits are read only and will return a value of 0b on read.

This register is expected to be written by the BIOS and the 82559ER driver should not write to it.

7.1.7 PCI Latency Timer

The Latency Timer register is a byte wide register. When the 82559ER is acting as a bus master, this register defines the amount of time, in PCI clock cycles, that it may own the bus.

7.1.8 PCI Header Type

The Header Type register is a byte read only register. It is hard-coded to equal to 00h for a single function card.

7.1.9 PCI Base Address Registers

One of the most important functions for enabling superior configurability and ease of use is the ability to relocate PCI devices in address spaces. The 82559ER contains three types of Base Address Registers (BARs). Two are used for memory mapped resources, and one is used for I/O mapping. Each register is 32 bits wide. The least significant bit in the BAR determines whether it represents a memory or I/O space. The figures below show the layout of a BAR for both memory and I/O mapping. After determining this information, power-up software can map the memory and I/O controllers into available locations and proceed with system boot. To do this mapping in a device independent manner, the base registers for this mapping are placed in the predefined header portion of configuration space. Device drivers can then access this configuration space to determine the mapping of a particular device.

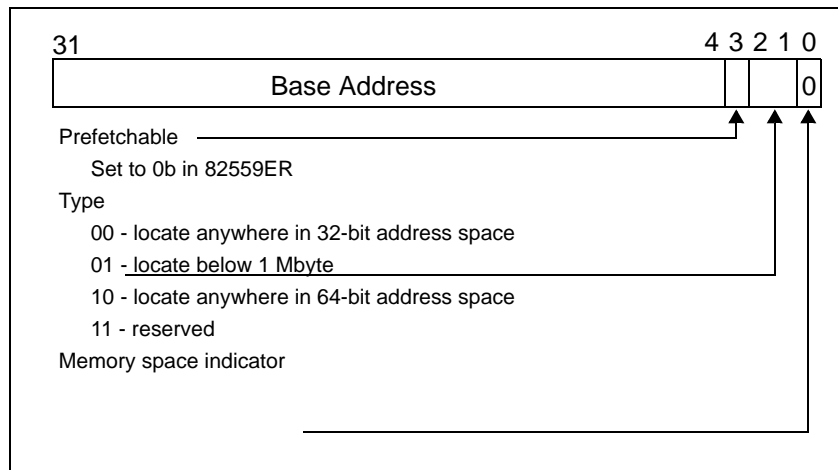

Figure 21. Base Address Register for Memory Mapping

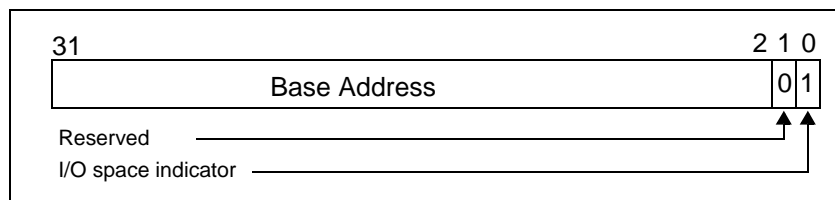

Figure 22. Base Address Register for I/O Mapping

Note: Bit 0 in all base registers is read only and used to determine whether the register maps into memory or I/O space. Base registers that map to memory space must return a 0b in bit 0. Base registers that map to I/O space must return 1b in bit 0.

Base registers that map into I/O space are always 32 bits wide with bit 0 hardwired to a 1b, bit 1 is reserved and must return 0b on reads, and the other bits are used to map the device into I/O space.

The number of upper bits that a device actually implements depends on how much of the address space the device will respond to. For example, a device that wants a 1 Mbyte memory address space would set the most significant 12 bits of the base address register to be configurable, setting the other bits to 0b.

The 82559ER contains BARs for the Control/Status Register (CSR), Flash, and Expansion ROM.

7.1.9.1 CSR Memory Mapped Base Address Register

The 82559ER requires one BAR for memory mapping. Software determines which BAR, memory or I/O, is used to access the 82559ER CSR registers.

The memory space for the 82559ER CSR Memory Mapped BAR is 4 Kbyte. It is marked as prefetchable space and is mapped anywhere in the 32-bit memory address space.

7.1.9.2 CSR I/O Mapped Base Address Register

The 82559ER requires one BAR for I/O mapping. Software determines which BAR, memory or I/O, is used to access the 82559ER CSR registers. The I/O space for the 82559ER CSR I/O BAR is 64 bytes.

7.1.9.3 Flash Memory Mapped Base Address Register

The Flash Memory BAR is a Dword register. The 82559ER physically supports up to a 128 Kbyte Flash device, and requests a 128Kbyte window. The 82559ER always claims a Flash memory window, regardless of whether or not a Flash device is connected (i.e. Flash Base Address Register cannot be disabled).

7.1.9.4 Expansion ROM Base Address Register

The Expansion ROM BAR is a Dword register and supports a 128 Kbyte memory via the 82559ER local bus. The Expansion ROM BAR can be disabled by setting the Boot Disable bit of the EEPROM (word AH, bit 11). The 82559ER requests a 1MB window for expansion ROM. If the Boot Disable bit is set, the 82559ER returns a 0b for all bits in this address register, avoiding request of memory allocation for this space.

7.1.10 PCI Subsystem Vendor ID and Subsystem ID Registers

The Subsystem Vendor ID field identifies the vendor of an 82559ER-based solution. The Subsystem Vendor ID values are based upon the vendor’s PCI Vendor ID and is controlled by the PCI Special Interest Group (SIG).

The Subsystem ID field identifies the 82559ER-based specific solution implemented by the vendor indicated in the Subsystem Vendor ID field.

The 82559ER provides support for configurable Subsystem Vendor ID and Subsystem ID fields. After hardware reset is de-asserted, the 82559ER automatically reads addresses Ah through Ch of the EEPROM. The first of these 16-bit values is used for controlling various 82559ER functions. The second is the Subsystem ID value, and the third is the Subsystem Vendor ID value. Again, the default values for the Subsystem ID and Subsystem Vendor ID are 0h and 0H, respectively.

The 82559ER checks bit numbers 15, 14, and 13 in the EEPROM, word Ah and functions according to [Table 6](#) below.

Table 6. 82559ER ID Fields Programming

Bits 15, 14	Bit 13	Device ID	Vendor ID	Revision ID	Subsystem ID	Subsystem Vendor ID
11b, 10b, 00b	X	1209H	8086H	09H	0000H (Default)	0000H (Default)
01b	0b	1209H	8086H	09H	Word BH	Word CH
01b	1b	1209H	8086H	Word AH, bits 10:8	Word BH	Word CH

Note: The Revision ID is subject to change according to the silicon stepping.

The above table implies that if the 82559ER detects the presence of an EEPROM (as indicated by a value of 01b in bits 15 and 14), then bit number 13 determines whether the values read from the EEPROM, words Bh and CH, will be loaded into the Subsystem ID (word BH) and Subsystem Vendor ID (word CH) fields. If bits 15 and 14 equal 01b and bit 13 equals 1b, the three least significant bits of the Revision ID field are programmed by bits 8-10 of the first EEPROM word, word AH.

Between the de-assertion of reset and the completion of the automatic EEPROM read, the 82559ER does not respond to any PCI configuration cycles. If the 82559ER happens to be accessed during this time, it will Retry the access. More information on Retry is provided in [Section 4.2.1.1.3, “Retry Premature Accesses”](#).

7.1.11 Capability Pointer

The Capability Pointer is a hard coded byte register with a value of DCH. It provides an offset within the Configuration Space for the location of the Power Management registers.

7.1.12 Interrupt Line Register

The Interrupt Line register identifies which system interrupt request line on the interrupt controller the device’s PCI interrupt request pin (as defined in the Interrupt Pin register) is routed to.

7.1.13 Interrupt Pin Register

The Interrupt Pin register is read only and defines which of the four PCI interrupt request pins, INTA# through INTD#, a PCI device is connected to. The 82559ER is connected the INTA# pin.

7.1.14 Minimum Grant Register

The Minimum Grant (Min_Gnt) register is an optional read only register for bus masters and is not applicable to non-master devices. It defines the amount of time the bus master wants to retain PCI bus ownership when it initiates a transaction. The default value of this register for the 82559ER is 08h. This can be converted to an actual time using the PCI specification ($8 * 1/PCIclk$), to a value of 242ns.

7.1.15 Maximum Latency Register

The Maximum Latency (Max_Lat) register is an optional read only register for bus masters and is not applicable to non-master devices. This register defines how often a device needs to access the PCI bus. The default value of this register for the 82559ER is 18h. This can be converted to an actual time using the PCI specification ($18h * 1/PCIclk$), to a value of 1 μ s.

7.1.16 Capability ID Register

The Capability ID is a byte register. It signifies whether the current item in the linked list is the register defined for PCI Power Management. PCI Power Management has been assigned the value of 01H.

7.1.17 Next Item Pointer

The Next Item Pointer is a byte register. It describes the location of the next item in the 82559ER's capability list. Since power management is the last item in the list, this register is set to 0b.

7.1.18 Power Management Capabilities Register

The Power Management Capabilities register is a word read only register. It provides information on the capabilities of the 82559ER related to power management. The 82559ER reports a value of FE21h if it is connected to an auxiliary power source and 7E21h otherwise. It indicates that the 82559ER supports wake-up in the D3 state if power is supplied, either V_{cc} or V_{AUX} .

Table 7. Power Management Capability Register

Bits	Default	Read/Write	Description
31:27	00011b (no V_{AUX}) 11111b (V_{AUX})	Read Only	PME Support. This five bit field indicates the power states in which the 82559ER may assert PME#. The 82559ER supports wake-up in all power states if it is fed by an auxiliary power supply (V_{AUX}) and D0, D1, D2, and D3 _{hot} if it is fed by PCI power.
26	1b	Read Only	D2 Support. If this bit is set, the 82559ER supports the D2 power state.
25	1b	Read Only	D1 Support. If this bit is set, the 82559ER supports the D1 power state.

Table 7. Power Management Capability Register

Bits	Default	Read/Write	Description
24:22	000b	Read Only	Auxiliary Current. This field reports whether the 82559ER implements the Data registers. The auxiliary power consumption is the same as the current consumption reported in the D3 state in the Data register.
21	1b	Read Only	Device Specific Initialization (DSI). The DSI bit indicates whether special initialization of this function is required (beyond the standard PCI configuration header) before the generic class device driver is able to use it. DSI is required for the 82559ER after D3-to-D0 reset.
20	0b (PCI)	Read Only	Reserved (PCI). When this bit is set to '1', it indicates that the 82559ER requires auxiliary power supplied by the system for wake-up from the D3 _{cold} state.
19	0b	Read Only	PME Clock. The 82559ER does not require a clock to generate a power management event.
18:16	010b	Read Only	Version. A value of indicates that the 82559ER complies with the PCI Power Management Specification, Revision 2.2.

7.1.19 Power Management Control/Status Register (PMCSR)

The Power Management Control/Status is a word register. It is used to determine and change the current power state of the 82559ER and control the power management interrupts in a standard manner.

Table 8. Power Management Control and Status Register

Bits	Default	Read/Write	Description
15	0b	Read/Clear	PME Status. This bit is set upon a wake-up event. It is independent of the state of the PME Enable bit. If 1b is written to this bit, the bit will be cleared. It also de-asserts the PME# signal and clears the PME status bit in the Power Management Driver Register. When the PME# signal is enabled, the PME# signal reflects the state of the PME status bit.
14:13	00b	Read Only	Data Scale. This field indicates the data register scaling factor. It equals 10b for registers zero through eight and 00b for registers nine through fifteen.
12:9	0000b	Read Only	Data Select. This field is used to select which data is reported through the Data register and Data Scale field.
8	0b	Read Clear	PME Enable. This bit enables the 82559ER to assert PME#.
7:5	000b	Read Only	Reserved. These bits are reserved and should be set to 000b.
4	0b	Read Only	Dynamic Data. The 82559ER does not support the ability to monitor the power consumption dynamically.
3:2	00b	Read Only	Reserved. These bits are reserved and should be set to 00b.
1:0	00b	Read/Write	Power State. This 2-bit field is used to determine the current power state of the 82559ER and to set the 82559ER into a new power state. The definition of the field values is as follows. 00 - D0 01 - D1 10 - D2 11 - D3

7.1.20 Data Register

The data register is an 8-bit read only register that provides a mechanism for the 82559ER to report state dependent maximum power consumption and heat dissipation. The value reported in this register depends on the value written to the Data Select field in the PMCSR register. The power measurements defined in this register have a dynamic range of 0 to 2.55 W with 0.01 W resolution according to the Data Scale. The value in this register is hard coded in the silicon. The structure of the data register is presented below.

Table 9. Ethernet Data Register

Data Select	Data Scale	Data Reported
0	2	D0 Power Consumption = 60 (600 mW)
1	2	D1 Power Consumption = 42 (420 mW)
2	2	D2 Power Consumption = 42 (420 mW)
3	2	D3 Power Consumption = 42 (420 mW)
4	2	D0 Power Dissipated = 58 (580 mW)
5	2	D1 Power Dissipated = 40 (400 mW)
6	2	D2 Power Dissipated = 40 (400 mW)
7	2	D3 Power Dissipated = 40 (400 mW)
8	2	Common Function Power Dissipated = 00
9-15	0	Reserved (00H)

MDI Control Register:	The MDI Control register allows the CPU to read and write information from the PHY unit (or an external PHY component) through the Management Data Interface.
Receive DMA Byte Count:	The Receive DMA Byte Count register keeps track of how many bytes of receive data have been passed into host memory via DMA.
Flow Control Register:	This register holds the flow control threshold value and indicates the flow control commands to the 82559ER.
PMDR:	The Power Management Driver Register provides an indication in memory and I/O space that a wake-up interrupt has occurred. The PMDR is described in further detail in Section 8.1.11, “Power Management Driver Register” on page 58.
General Control:	The General Control register allows the 82559ER to enter the deep power-down state and provides the ability to disable the Clockrun functionality. The General Control register is described in further detail in Section 8.1.12, “General Control Register” on page 59.
General Status:	The General Status register describes the status of the 82559ER’s duplex mode, speed, and link. The General Status register is detailed in Section 8.1.13, “General Status Register” on page 59.

8.1.1 System Control Block Status Word

The System Control Block (SCB) Status Word contains status information relating to the 82559ER’s Command and Receive units.

Bits	Name	Description
15	CX	Command Unit (CU) Executed. The CX bit indicates that the CU has completed executing a command with its interrupt bit set.
14	FR	Frame Received. The FR bit indicates that the Receive Unit (RU) has finished receiving a frame.
13	CNA	CU Not Active. The CNA bit is set when the CU is no longer active and in either an idle or suspended state.
12	RNR	Receive Not Ready. The RNR bit is set when the RU is not in the ready state. This may be caused by an RU Abort command, a no resources situation, or set suspend bit due to a filled Receive Frame Descriptor.
11	MDI	Management Data Interrupt. The MDI bit is set when a Management Data Interface read or write cycle has completed. The management data interrupt is enabled through the interrupt enable bit (bit 29 in the Management Data Interface Control register in the CSR).
10	SWI	Software Interrupt. The SWI bit is set when software generates an interrupt.
9	ER	Early Receive. The ER bit is used for early receive interrupts.
8	FCP	Flow Control Pause. The FCP bit is used as the flow control pause bit.
7:6	CUS	Command Unit Status. The CUS field contains the status of the Command Unit.
5:2	RUS	Receive Unit Status. The RUS field contains the status of the Receive Unit.
1:0	Reserved	These bits are reserved and should be set to 00b.

8.1.2 System Control Block Command Word

Commands for the 82559ER’s Command and Receive units are placed in this register by the CPU.

Bits	Name	Description
31:26	Specific Interrupt Mask	Specific Interrupt Mask. Setting this bit to 1b causes the 82559ER to stop generating an interrupt (in other words, de-assert the INTA# signal) on the corresponding event.
25	SI	Software Generated Interrupt. Setting this bit to 1b causes the 82559ER to generate an interrupt. Writing a 0b to this bit has no effect.
24	M	Interrupt Mask. If the Interrupt Mask bit is set to 1b, the 82559ER will not assert its INTA# pin. The M bit has higher precedence than the Specific Interrupt Mask bits and the SI bit.
23:20	CUC	Command Unit Command. This field contains the CU command.
19	Reserved	This bit is reserved and should be set to 0b.
18:16	RUC	Receive Unit Command. This field contains the RU command.

8.1.3 System Control Block General Pointer

The System Control Block (SCB) General Pointer is a 32-bit field that points to various data structures depending on the command in the CU Command or RU Command field.

8.1.4 PORT

The PORT interface allows software to perform certain control functions on the 82559ER. This field is 32 bits wide:

- Address and Data (bits 32:4)
- PORT Function Selection (bits 3:0)
The 82559ER supports four PORT commands: Software Reset, Self-test, Selective Reset, and Dump.

8.1.5 Flash Control Register

The Flash Control Register is a 32-bit field that allows access to an external Flash device.

8.1.6 EEPROM Control Register

The EEPROM Control Register is a 32-bit field that enables a read from and a write to the external EEPROM.

8.1.7 Management Data Interface Control Register

The Management Data Interface (MDI) Control register is a 32-bit field and is used to read and write bits from the MDI.

Bits	Description
31:30	These bits are reserved and should be set to 00b.

Bits	Description
29	Interrupt Enable. When this bit is set to 1b by software, the 82559ER asserts an interrupt to indicate the end of an MDI cycle.
28	Ready. This bit is set to 1b by the 82559ER at the end of an MDI transaction. It should be reset to 0b by software at the same time the command is written.
27:26	Opcode. These bits define the opcode: 01 for MDI write and 10 for MDI read. All other values (00 and 11) are reserved.
25:21	PHY Address. This field of bits contains the PHY address (Default = 00001b).
20:16	PHY Register Address. This field of bits contains the address of the PHY Register to be accessed.
15:0	Data. In a write command, software places the data bits in this field, and the 82559ER transfers the data to the PHY unit. During a read command, the 82559ER reads these bits serially from the PHY register (specified by bits 20:16), and software reads the data from this location.

8.1.8 Receive Direct Memory Access Byte Count

The Receive DMA Byte Count register keeps track of how many bytes of receive data have been passed into host memory via DMA.

8.1.9 Early Receive Interrupt

The Early Receive Interrupt register allows the 82559ER to generate an early interrupt depending on the length of the frame. An early interrupt is indicated by the ER bit in the SCB Status Word and the assertion of the INTA# signal.

8.1.10 Flow Control Register

The Flow Control Register contains the following fields:

- Flow Control Command
The Flow Control Command field describes the action of the flow control process (for example, pause, on, or off).
- Flow Control Threshold
The Flow Control Threshold field contains the threshold value (in other words, the number of free bytes in the Receive FIFO).

8.1.11 Power Management Driver Register

The 82559ER provides an indication in memory and I/O space that a wake-up event has occurred. It is located in the PMDR.

Table 10. Power Management Driver Register

Bits	Default	Read/Write	Description
31	0b	Read/Clear	Link Status Change Indication. The link status change bit is set following a change in link status and is cleared by writing a 1b to it.
30	0b	Read	Not Supported, will always read as a '0'.

Table 10. Power Management Driver Register

Bits	Default	Read/Write	Description
29	0b	Read/Clear	Interesting Packet. This bit is set when an “interesting” packet is received. Interesting packets are defined by the 82559ER packet filters. This bit is cleared by writing 1b to it.
28:26	000b	Read Only	Reserved. These bits are reserved and should be set to 000b.
25	0b	Read/Clear	Reserved. These bit is reserved and should be set to 0b.
24	0b	Read/Clear	PME Status. This bit is a reflection of the PME Status bit in the Power Management Control/Status Register (PMCSR). It is set upon a wake-up event and is independent of the PME Enable bit. This bit is cleared by writing 1b to it. This also clears the PME Status bit in the PMCSR and de-asserts the PME signal. I

Note: The PMDR is initialized at ALTRST# reset only.

8.1.12 General Control Register

The General Control register is a byte register and is described below.

Table 11. General Control Register

Bits	Default	Read/Write	Description
7:2	000000b	Read Only	Reserved. These bits are reserved and should be set to 000000b.
1	0b	Read/Write	Deep Power-Down on Link Down Enable. If a 1b is written to this field, the 82559ER may enter a deep power-down state (sub-3 mA) in the D2 and D3 power states while the link is down. In this state, the 82559ER does not keep link integrity. This state is not supported for point-to-point connection of two end stations.
0	0b	Read/Write	Clockrun Signal Disable. If this bit is set to 1b, then the 82559ER will always request the PCI clock signal. This mode can be used to overcome potential receive overruns caused by Clockrun signal latencies over 5 μ s.

8.1.13 General Status Register

The General Status register is a byte register which indicates the link status of the 82559ER.

Table 12. General Status Register

Bits	Default	Read/Write	Description
7:3	00000b	Read Only	Reserved. These bits are reserved and should be set to 00000b.
2	--	Read Only	Duplex Mode. This bit indicates the wire duplex mode: full duplex (1b) or half duplex (0b).
1	--	Read Only	Speed. This bit indicates the wire speed: 100 Mbps (1b) or 10 Mbps (0b).
0	0b	Read Only	Link Status Indication. This bit indicates the status of the link: valid (1b) or invalid (0b).

8.2 Statistical Counters

The 82559ER provides information for network management statistics by providing on-chip statistical counters that count a variety of events associated with both transmit and receive. The counters are updated by the 82559ER when it completes the processing of a frame (that is, when it has completed transmitting a frame on the link or when it has completed receiving a frame). The Statistical Counters are reported to the software on demand by issuing the Dump Statistical Counters command or Dump and Reset Statistical Counters command in the SCB Command Unit Command (CUC) field.

Table 13. 82559ER Statistical Counters

ID	Counter	Description
0	Transmit Good Frames	This counter contains the number of frames that were transmitted properly on the link. It is updated only after the actual transmission on the link is completed, not when the frame was read from memory as is done for the Transmit Command Block status.
4	Transmit Maximum Collisions (MAXCOL) Errors	This counter contains the number of frames that were not transmitted because they encountered the configured maximum number of collisions.
8	Transmit Late Collisions (LATECOL) Errors	This counter contains the number of frames that were not transmitted since they encountered a collision later than the configured slot time.
12	Transmit Underrun Errors	A transmit underrun occurs because the system bus cannot keep up with the transmission. This counter contains the number of frames that were either not transmitted or retransmitted due to a transmit DMA underrun. If the 82559ER is configured to retransmit on underrun, this counter may be updated multiple times for a single frame.
16	Transmit Lost Carrier Sense (CRS)	This counter contains the number of frames that were transmitted by the 82559ER despite the fact that it detected the de-assertion of CRS during the transmission.
20	Transmit Deferred	This counter contains the number of frames that were deferred before transmission due to activity on the link.
24	Transmit Single Collisions	This counter contains the number of transmitted frames that encountered one collision.
28	Transmit Multiple Collisions	This counter contains the number of transmitted frames that encountered more than one collision.
32	Transmit Total Collisions	This counter contains the total number of collisions that were encountered while attempting to transmit. This count includes late collisions and frames that encountered MAXCOL.
36	Receive Good Frames	This counter contains the number of frames that were received properly from the link. It is updated only after the actual reception from the link is completed and all the data bytes are stored in memory.
40	Receive CRC Errors	This counter contains the number of aligned frames discarded because of a CRC error. This counter is updated, if needed, regardless of the Receive Unit state. The Receive CRC Errors counter is mutually exclusive of the Receive Alignment Errors and Receive Short Frame Errors counters.
44	Receive Alignment Errors	This counter contains the number of frames that are both misaligned (for example, CRS de-asserts on a non-octal boundary) and contain a CRC error. The counter is updated, if needed, regardless of the Receive Unit state. The Receive Alignment Errors counter is mutually exclusive of the Receive CRC Errors and Receive Short Frame Errors counters.

Table 13. 82559ER Statistical Counters

ID	Counter	Description
48	Receive Resource Errors	This counter contains the number of good frames discarded due to unavailability of resources. Frames intended for a host whose Receive Unit is in the No Resources state fall into this category. If the 82559ER is configured to Save Bad Frames and the status of the received frame indicates that it is a bad frame, the Receive Resource Errors counter is not updated.
52	Receive Overrun Errors	This counter contains the number of frames known to be lost because the local system bus was not available. If the traffic problem persists for more than one frame, the frames that follow the first are also lost; however, because there is no lost frame indicator, they are not counted.
56	Receive Collision Detect (CDT)	This counter contains the number of frames that encountered collisions during frame reception.
60	Receive Short Frame Errors	This counter contains the number of received frames that are shorter than the minimum frame length. The Receive Short Frame Errors counter is mutually exclusive to the Receive Alignment Errors and Receive CRC Errors counters. A short frame will always increment only the Receive Short Frame Errors counter.
64	Flow Control Transmit Pause	This counter contains the number of Flow Control frames transmitted by the 82559ER. This count includes both the Xoff frames transmitted and Xon (PAUSE(0)) frames transmitted.
68	Flow Control Receive Pause	This counter contains the number of Flow Control frames received by the 82559ER. This count includes both the Xoff frames received and Xon (PAUSE(0)) frames received.
72	Flow Control Receive Unsupported	This counter contains the number of MAC Control frames received by the 82559ER that are not Flow Control Pause frames. These frames are valid MAC control frames that have the predefined MAC control Type value and a valid address but has an unsupported opcode.

The Statistical Counters are initially set to zero by the 82559ER after reset. They cannot be preset to anything other than zero. The 82559ER increments the counters by internally reading them, incrementing them and writing them back. This process is invisible to the CPU and PCI bus. In addition, the counters adhere to the following rules:

- The counters are wrap-around counters. After reaching FFFFFFFFh the counters wrap around to 0.
- The 82559ER updates the required counters for each frame. It is possible for more than one counter to be updated as multiple errors can occur in a single frame.
- The counters are 32 bits wide and their behavior is fully compatible with the IEEE 802.1 standard. The 82559ER supports all mandatory and recommend statistics functions through the status of the receive header and directly through these Statistical Counters.

The CPU can access the counters by issuing a Dump Statistical Counters SCB command. This provides a “snapshot”, in main memory, of the internal 82559ER statistical counters. The 82559ER supports 21 counters.

The counters are initialized by power-up reset driven on the ALTRST# pin.



Note: This page left intentionally blank.

9.0 PHY Unit Registers

The 82559ER provides status and accepts management information via the Management Data Interface (MDI) within the CSR space.

Acronyms mentioned in the registers are defined as follows:

- SC - self cleared
- RO - read only
- E - EEPROM setting affects content
- LL - latch low
- LH - latch high

9.1 MDI Registers 0 - 7

9.1.1 Register 0: Control Register Bit Definitions

Bit(s)	Name	Description	Default	R/W
15	Reset	This bit sets the status and control register of the PHY to their default states and is self-clearing. The PHY returns a value of one until the reset process has completed and accepts a read or write transaction. 1 = PHY Reset	0	RW SC
14	Loopback	This bit enables loopback of transmit data nibbles from the TXD[3:0] signals to the receive data path. The PHY unit's receive circuitry is isolated from the network. Note that this may cause the descrambler to lose synchronization and produce 560 nanoseconds of "dead time." Note also that the loopback configuration bit takes priority over the Loopback MDI bit. 1 = Loopback enabled 0 = Loopback disabled (Normal operation)	0	RW
13	Speed Selection	This bit controls speed when Auto-Negotiation is disabled and is valid on read when Auto-Negotiation is disabled. 1 = 100 Mbps 0 = 10 Mbps	1	RW
12	Auto-Negotiation Enable	This bit enables Auto-Negotiation. Bits 13 and 8, Speed Selection and Duplex Mode, respectively, are ignored when Auto-Negotiation is enabled. 1 = Auto-Negotiation enabled 0 = Auto-Negotiation disabled	1	RW
11	Power-Down	This bit sets the PHY unit into a low power mode. In low power mode, the PHY unit consumes no more than 30 mA. 1 = Power-Down enabled 0 = Power-Down disabled (Normal operation)	0	RW
10	Reserved	This bit is reserved and should be set to 0b.	0	RW

Bit(s)	Name	Description	Default	R/W
9	Restart Auto-Negotiation	This bit restarts the Auto-Negotiation process and is self-clearing. 1 = Restart Auto-Negotiation process	0	RW SC
8	Duplex Mode	This bit controls the duplex mode when Auto-Negotiation is disabled. If the PHY reports that it is only able to operate in one duplex mode, the value of this bit shall correspond to the mode which the PHY can operate. When the PHY is placed in Loopback mode, the behavior of the PHY shall not be affected by the status of this bit, bit 8. 1 = Full Duplex 0 = Half Duplex	0	RW
7	Collision Test	This bit will force a collision in response to the assertion of the transmit enable signal. 1 = Force COL 0 = Do not force COL	0	RW
6:0	Reserved	These bits are reserved and should be set to 0000000b.	0	RW

9.1.2 Register 1: Status Register Bit Definitions

Bit(s)	Name	Description	Default	R/W
15	Reserved	This bit is reserved and should be set to 0b.	0	RO E
14	100BASE-TX Full Duplex	1 = PHY able to perform full duplex 100BASE-TX	1	RO
13	100 Mbps Half Duplex	1 = PHY able to perform half duplex 100BASE-TX	1	RO
12	10 Mbps Full Duplex	1 = PHY able to operate at 10Mbps in full duplex mode	1	RO
11	10 Mbps Half Duplex	1 = PHY able to operate at 10 Mbps in half duplex mode	1	RO
10:7	Reserved	These bits are reserved and should be set to 0000b.	0	RO
6	Management Frames Preamble Suppression	0 = PHY will not accept management frames with preamble suppressed	0	RO
5	Auto-Negotiation Complete	1 = Auto-Negotiation process completed 0 = Auto-Negotiation process has not completed	0	RO
4	Remote Fault	0 = No remote fault condition detected	0	RO
3	Auto-Negotiation Ability	1 = PHY is able to perform Auto-Negotiation	1	RO
2	Link Status	1 = Valid link has been established 0 = Invalid link detected	0	RO LL
1	Jabber Detect	1 = Jabber condition detected 0 = No jabber condition detected	0	RO LH
0	Extended Capability	1 = Extended register capabilities enabled	1	RO

9.1.3 Register 2: PHY Identifier Register Bit Definitions

Bit(s)	Name	Description	Default	R/W
15:0	PHY ID (high byte)	Value: 02A8H	--	RO

9.1.4 Register 3: PHY Identifier Register Bit Definitions

Bit(s)	Name	Description	Default	R/W
15:0	PHY ID (low byte)	Value: 0154H	--	RO

9.1.5 Register 4: Auto-Negotiation Advertisement Register Bit Definitions

Bit(s)	Name	Description	Default	R/W
15	Next Page	Constant 0 = Transmitting primary capability data page	0	RO
14	Reserved	This bit is reserved and should be set to 0b.	0	RO
13	Remote Fault	1 = Indicate link partner's remote fault 0 = No remote fault	0	RW
12:5	Technology Ability Field	Technology Ability Field is an 8-bit field containing information indicating supported technologies specific to the selector field value.	00101111	RW
4:0	Selector Field	The Selector Field is a 5-bit field identifying the type of message to be sent via Auto-Negotiation. This field is read only in the 82559ER and contains a value of 00001b, IEEE Standard 802.3.	00001	RO

9.1.6 Register 5: Auto-Negotiation Link Partner Ability Register Bit Definitions

Bit(s)	Name	Description	Default	R/W
15	Next Page	This bit reflects the PHY's link partner's Auto-Negotiation ability.	--	RO
14	Acknowledge	This bit is used to indicate that the 82559ER's PHY unit has successfully received its link partner's Auto-Negotiation advertising ability.	--	RO
13	Remote Fault	This bit reflects the PHY's link partner's Auto-Negotiation ability.	--	RO
12:5	Technology Ability Field	This bit reflects the PHY's link partner's Auto-Negotiation ability.	--	RO
4:0	Selector Field	This bit reflects the PHY's link partner's Auto-Negotiation ability.	--	RO

9.1.7 Register 6: Auto-Negotiation Expansion Register Bit Definitions

Bit(s)	Name	Description	Default	R/W
15:5	Reserved	These bits are reserved and should be set to 0b.	0	RO
4	Parallel Detection Fault	1 = Fault detected via parallel detection (multiple link fault occurred) 0 = No fault detected via parallel detection This bit will self-clear on read	0	RO SC LH
3	Link Partner Next page Able	1 = Link Partner is Next Page able 0 = Link Partner is not Next Page able	0	RO
2	Next Page Able	1 = Local drive is Next Page able 0 = Local drive is not Next Page able	0	RO
1	Page Received	1 = New Page received 0 = New Page not received This bit will self-clear on read.	0	RO SC LH
0	Link Partner Auto-Negotiation Able	1 = Link Partner is Auto-Negotiation able 0 = Link Partner is not Auto-Negotiation able	0	RO

9.2 MDI Registers 8 - 15

Registers eight through fifteen are reserved for IEEE.

9.3 MDI Register 16 - 31

9.3.1 Register 16: PHY Unit Status and Control Register Bit Definitions

Bit(s)	Name	Description	Default	R/W
15:14	Reserved	These bits are reserved and should be set to 00b	00	RW
13	Carrier Sense Disconnect Control	This bit enables the disconnect function. 1 = Disconnect function enabled 0 = Disconnect function disabled	0	RW
12	Transmit Flow Control Disable	This bit enables Transmit Flow Control 1 = Transmit Flow Control enabled 0 = Transmit Flow Control disabled	0	RW
11	Receive De-Serializer In-Sync Indication	This bit indicates status of the 100BASE-TX Receive De-Serializer In-Sync.	--	RO
10	100BASE-TX Power-Down	This bit indicates the power state of 100BASE-TX PHY unit. 1 = Power-Down 0 = Normal operation	1	RO
9	10BASE-T Power-Down	This bit indicates the power state of 100BASE-TX PHY unit. 1 = Power-Down 0 = Normal operation	1	RO

Bit(s)	Name	Description	Default	R/W
8	Polarity	This bit indicates 10BASE-T polarity. 1 = Reverse polarity 0 = Normal polarity	--	RO
7:2	Reserved	These bits are reserved and should be set to 0B.	000000	RO
1	Speed	This bit indicates the Auto-Negotiation result. 1 = 100 Mbps 0 = 10 Mbps	--	RO
0	Duplex Mode	This bit indicates the Auto-Negotiation result. 1 = Full Duplex 0 = Half Duplex	--	RO

9.3.2 Register 17: PHY Unit Special Control Bit Definitions

Bit(s)	Name	Description	Default	R/W
15	Scrambler By-pass	1 = By-pass Scrambler 0 = Normal operations	0	RW
14	By-pass 4B/5B	1 = 4 bit to 5 bit by-pass 0 = Normal operation	0	RW
13	Force Transmit H-Pattern	1 = Force transmit H-pattern 0 = Normal operation	0	RW
12	Force 34 Transmit Pattern	1 = Force 34 transmit pattern 0 = Normal operation	0	RW
11	Good Link	1 = 100BASE-TX link good 0 = Normal operation	0	RW
10	Reserved	This bit is reserved and should be set to 0b.	0	RW
9	Transmit Carrier Sense Disable	1 = Transmit Carrier Sense disabled 0 = Transmit Carrier Sense enabled	0	RW
8	Disable Dynamic Power-Down	1 = Dynamic Power-Down disabled 0 = Dynamic Power-Down enabled (normal)	0	RW
7	Auto-Negotiation Loopback	1 = Auto-Negotiation loopback 0 = Auto-Negotiation normal mode	0	RW
6	MDI Tri-State	1 = MDI Tri-state (transmit driver tri-states) 0 = Normal operation	0	RW
5	Filter By-pass	1 = By-pass filter 0 = Normal filter operation	0	RW
4	Auto Polarity Disable	1 = Auto Polarity disabled 0 = Normal polarity operation	0	RW
3	Squelch Disable	1 = 10BASE-T squelch test disable 0 = Normal squelch operation	0	RW
2	Extended Squelch	1 = 10BASE-T Extended Squelch control enabled 0 = 10BASE-T Extended Squelch control disabled	0	RW
1	Link Integrity Disable	1 = Link disabled 0 = Normal Link Integrity operation	0	RW

Bit(s)	Name	Description	Default	R/W
0	Jabber Function Disable	1 = Jabber disabled 0 = Normal Jabber operation	0	RW

9.3.3 Register 18: PHY Address Register

Bit(s)	Name	Description	Default	R/W
15:5	Reserved	These bits are reserved and should be set to a constant '0'	0	RO
4:0	PHY Address	These bits are set to the PHY's address, 00001b.	1	RO

9.3.4 Register 19: 100BASE-TX Receive False Carrier Counter Bit Definitions

Bit(s)	Name	Description	Default	R/W
15:0	Receive False Carrier	These bits are used for the false carrier counter.	--	RO SC

9.3.5 Register 20: 100BASE-TX Receive Disconnect Counter Bit Definitions

Bit(s)	Name	Description	Default	R/W
15:0	Disconnect Event	This field contains a 16-bit counter that increments for each disconnect event. The counter freezes when full and self-clears on read	--	RO SC

9.3.6 Register 21: 100BASE-TX Receive Error Frame Counter Bit Definitions

Bit(s)	Name	Description	Default	R/W
15:0	Receive Error Frame	This field contains a 16-bit counter that increments once per frame for any receive error condition (such as a symbol error or premature end of frame) in that frame. The counter freezes when full and self-clears on read.	--	RO SC

9.3.7 Register 22: Receive Symbol Error Counter Bit Definitions

Bit(s)	Name	Description	Default	R/W
15:0	Symbol Error Counter	This field contains a 16-bit counter that increments for each symbol error. The counter freezes when full and self-clears on read. In a frame with a bad symbol, each sequential six bad symbols count as one.	--	RO SC

9.3.8 Register 23: 100BASE-TX Receive Premature End of Frame Error Counter Bit Definitions

Bit(s)	Name	Description	Default	R/W
15:0	Premature End of Frame	This field contains a 16-bit counter that increments for each premature end of frame event. The counter freezes when full and self-clears on read.	--	RO SC

9.3.9 Register 24: 10BASE-T Receive End of Frame Error Counter Bit Definitions

Bit(s)	Name	Description	Default	R/W
15:0	End of Frame Counter	This is a 16-bit counter that increments for each end of frame error event. The counter freezes when full and self-clears on read.	--	RO SC

9.3.10 Register 25: 10BASE-T Transmit Jabber Detect Counter Bit Definitions

Bit(s)	Name	Description	Default	R/W
15:0	Jabber Detect Counter	This is a 16-bit counter that increments for each jabber detection event. The counter freezes when full and self-clears on read.	--	RO SC

9.3.11 Register 26: Equalizer Control and Status Bit Definitions

Bit(s)	Name	Description	Default	R/W
15:0	RFU	Reserved for Future Use	--	RW

9.3.12 Register 27: PHY Unit Special Control Bit Definitions

Bit(s)	Name	Description	Default	R/W																											
15:3	Reserved	These bits are reserved and should be set to 0b.	0	RW																											
2:0	LED Switch Control	<table border="1"> <thead> <tr> <th>Value</th> <th>ACTLED</th> <th>LILED</th> </tr> </thead> <tbody> <tr> <td>000</td> <td>Activity</td> <td>Link</td> </tr> <tr> <td>001</td> <td>Speed</td> <td>Collision</td> </tr> <tr> <td>010</td> <td>Speed</td> <td>Link</td> </tr> <tr> <td>011</td> <td>Activity</td> <td>Collision</td> </tr> <tr> <td>100</td> <td>Off</td> <td>Off</td> </tr> <tr> <td>101</td> <td>Off</td> <td>On</td> </tr> <tr> <td>110</td> <td>On</td> <td>Off</td> </tr> <tr> <td>111</td> <td>On</td> <td>On</td> </tr> </tbody> </table>	Value	ACTLED	LILED	000	Activity	Link	001	Speed	Collision	010	Speed	Link	011	Activity	Collision	100	Off	Off	101	Off	On	110	On	Off	111	On	On	000	RW
Value	ACTLED	LILED																													
000	Activity	Link																													
001	Speed	Collision																													
010	Speed	Link																													
011	Activity	Collision																													
100	Off	Off																													
101	Off	On																													
110	On	Off																													
111	On	On																													



Note: This page left intentionally blank.

10.0 Electrical and Timing Specifications

10.1 Absolute Maximum Ratings

Maximum ratings are listed below:

Case Temperature under Bias (standard temperature part)	0 C to 85 C
Storage Temperature	-65 C to 140 C
Outputs and Supply Voltages (except PCI and SMB)	-0.5 V to 5.0 V
PCI and SMB Output Voltages	-0.50 V to 5.25 V
Transmit Data Output Voltage	-0.5 V to 8.0 V
Input Voltages (except PCI and SMB)	-1.0 V to 5.0 V
PCI and SMB Input Voltages	-0.5 V 6.0 V

Stresses above the listed absolute maximum ratings may cause permanent damage to the 82559ER device. This is a stress rating only and functional operations of the device at these or any other conditions above those indicated in the operational sections of this specification is not implied. Exposure to absolute maximum rating conditions for extended periods may affect device reliability.

10.2 DC Specifications

Table 14. General DC Specifications

Symbol	Parameter	Condition	Min	Typical	Max	Units	Notes
V_{CC}	Supply Voltage		3.0	3.3	3.5	V	
V_{IO}	Periphery Clamp Voltage	PCI	4.75	5.0	5.25	V	1
I_{CC}	Power Supply			125	195	mA	2

NOTES:

1. The V_{IO} pin is the voltage bias pin for the PCI interface. This pin should be connected to $V \pm 5\%$ in a 5 volt PCI system and 3.3 volts in a 3.3 volt PCI system. Be sure to install a 100 K Ω pull-up resistor. This resistor acts as a current limit resistor in systems where the V_{IO} bias voltage may be shutdown. In this case, the 82559ER may consume additional current without a resistor.
2. Typical current consumption is in nominal operating conditions ($V_{CC} = 3.3$ V) and average link activity. Maximum current consumption is in maximum V_{CC} and maximum link activity.

The case temperature under bias is 0 C to 70 C for the standard temperature part and -25 C to 85 C for the extended temperature part.

The 82559ER supports both the PCI interface standards. The 82559ER is five volts tolerant and supports both 5 V and 3.3 V signaling environments.

Table 15. PCI/CardBus Interface DC Specifications

Symbol	Parameter	Condition	Min	Max	Units	Notes
V_{IHP}	Input High Voltage		$0.475V_{CC}$	$V_{IO} + 0.5$	V	
V_{ILP}	Input Low Voltage		-0.5	$0.325V_{CC}$	V	
V_{IPUP}	Input Pull-up Voltage		$0.7V_{CC}$		V	1
V_{IPDP}	Input Pull-down Voltage			$0.2V_{CC}$	V	1

Table 15. PCI/CardBus Interface DC Specifications

I _{ILP}	Input Leakage Current	0 < V _{in} < V _{CC}		±10	μA	2
V _{OHP}	Output High Voltage	I _{out} = -2 mA I _{out} = -500 μA	2.4 0.9V _{CC}		V V	PCI
V _{OLP}	Output Low Voltage	I _{out} = 3 mA, 6 mA I _{out} = 1500 μA		0.55 0.1V _{CC}	V V	3, PCI
C _{INP}	Input Pin Capacitance			10	pF	4
C _{CLKP}	CLK Pin Capacitance		5	12	pF	4
C _{IDSEL}	IDSEL Pin Capacitance			8	pF	4
L _{PINP}	Pin Inductance			12	nH	4

NOTES:

1. These values are only applicable in 3.3 V signaling environments. Outside of this limit the input buffer must consume its minimum current.
2. Input leakage currents include high-Z output leakage for all bidirectional buffers with tristate outputs.
3. Signals without pull-up resistors have 3 mA low output current; and signals requiring pull-up resistors, 6 mA. The signals requiring pull-up resistors include: FRAME#, TRDY#, IRDY#, DEVSEL#, STOP#, SERR# and PERR#.
4. This value is characterized but not tested.

Table 16. Flash/EEPROM Interface DC Specifications

Symbol	Parameter	Condition	Min	Max	Units	Notes
V _{IHL}	Input High Voltage		2.0	V _{CC} + 0.5	V	
V _{ILL}	Input Low Voltage		-0.5	0.8	V	
I _{ILL}	Input Low Leakage Current	0 < V _{in} < V _{CC}		±20	μA	
V _{OHL}	Output High Voltage	I _{out} = -1 mA	2.4		V	
V _{OLL}	Output Low Voltage	I _{out} = 2mA		0.4	V	
C _{INL}	Input Pin Capacitance			10	pF	1

NOTE:

1. This value is characterized but not tested.

Table 17. LED Voltage/Current Characteristics

Symbol	Parameter	Condition	Min	Typical	Max	Units	Notes
V _{OHLED}	Output High Voltage	I _{out} = -10 mA	2.4			V	
V _{OLLED}	Output Low Voltage	I _{out} = 10 mA			0.7	V	

Table 18. 100BASE-TX Voltage/Current Characteristics

Symbol	Parameter	Condition	Min	Typical	Max	Units	Notes
R _{ID100}	Input Differential Impedance	DC	10			KΩ	
V _{IDA100}	Input Differential Accept Peak Voltage		±500			mV	

Table 18. 100BASE-TX Voltage/Current Characteristics

V_{IDR100}	Input Differential Reject Peak Voltage				± 100	mV	
V_{ICM100}	Input Common Mode Voltage			$V_{CC}/2$		V	
V_{OD100}	Output Differential Peak Voltage		0.95	1.00	1.05	V	
I_{CCT100}	Line Driver Supply Peak Current	$R_{BIAS100} = 619 \Omega$		20		mA	1

NOTES:

1. Current is measured on all V_{CC} pins ($V_{CC} = 3.3$ V).
2. Transmitter peak current is attained by dividing the measured maximum differential output peak voltage by the load resistance value.

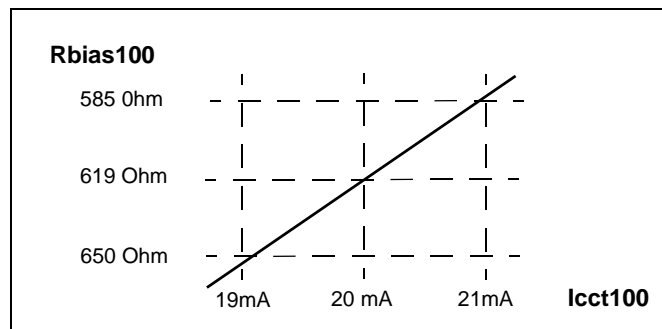
Figure 24. RBIAS100 Resistance Versus Transmitter Current
Table 19. 10BASE-T Voltage/Current Characteristics

Symbol	Parameter	Condition	Min	Typical	Max	Units	Notes
R_{ID10}	Input Differential Impedance	10 MHz	10			K Ω	
V_{IDA10}	Input Differential Accept Peak Voltage	$5 \text{ MHz} \leq f \leq 10 \text{ MHz}$	± 585		± 3100	mV	
V_{IDR10}	Input Differential Reject Peak Voltage	$5 \text{ MHz} \leq f \leq 10 \text{ MHz}$			± 300	mV	
V_{ICM10}	Input Common Mode Voltage			$V_{CC}/2$		V	
V_{OD10}	Output Differential Peak Voltage	$R_L = 100 \Omega$	2.2		2.8	V	
I_{CCT10}	Line Driver Supply Peak Current	$R_{BIAS10} = 549 \Omega$		48		mA	1

NOTES:

1. Current is measured on all V_{CC} pins ($V_{CC} = 3.3$ V).
2. Transmitter peak current is attained by dividing the measured maximum differential output peak voltage by the load resistance value.

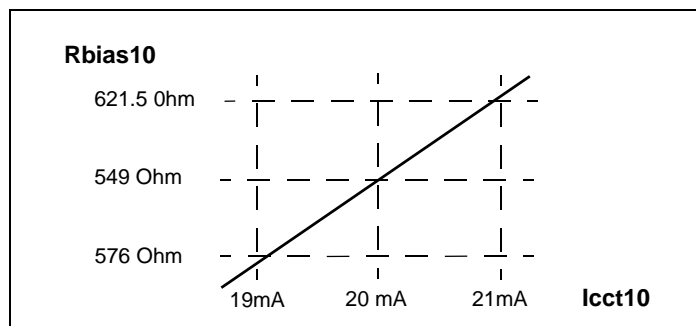

Figure 25. RBIAS10 Resistance Versus Transmitter Current

10.3 AC Specifications

Table 20. AC Specifications for PCI Signaling

Symbol	Parameter	Condition	Min	Max	Units	Notes
$I_{OH(AC)}$	Switching Current High	$0 < V_{out} \leq 1.4$	-44		mA	1
		$1.4 < V_{out} < 0.9V_{CC}$	$-17.1(V_{CC} - V_{out})$		mA	1
		$0.7V_{CC} < V_{out} < V_{CC}$		Eqn A	mA	2
	(Test Point)	$V_{out} = 0.7V_{CC}$		$-32V_{CC}$	mA	2
$I_{OL(AC)}$	Switching Current Low	$V_{out} \geq 2.2$	95		mA	1
		$2.2 > V_{out} > 0.1V_{CC}$	$V_{out}/0.023$		mA	1
		$0.18V_{CC} > V_{out} > 0$		Eqn B	mA	2
	(Test Point)	$V_{out} = 0.18V_{CC}$		$38V_{CC}$	mA	2
I_{CL}	Low Clamp Current	$-3 < V_{in} \leq -1$	$-25 + (V_{in} + 1)/0.015$		mA	3
I_{CH}	High Clamp Current	$V_{CC} + 4 > V_{in} \geq V_{CC} + 1$	$25 + (V_{in} - V_{CC} - 1)/0.015$		mA	3
$slew_{RP}$	PCI Output Rise Slew Rate	0.4 V to 2.4 V	1	4	V/ns	
$slew_{FP}$	PCI Output Fall Slew Rate	2.4 V to 0.4 V	1	4	V/ns	

NOTES:

- Switching Current High specifications are not relevant to PME#, SERR#, or INTA#, which are open drain outputs.
- Maximum current requirements will be met as drivers pull beyond the first step voltage (AC drive point). Equations defining these maximums (A and B) are provided. To facilitate component testing, a maximum current test point is defined for each side of the output driver.

Equation A. $I_{OH} = (98/V_{CC}) \cdot (V_{out} - V_{CC}) \cdot (V_{out} + 0.4V_{CC})$, for $V_{CC} > V_{out} > 0.7V_{CC}$

Equation B. $I_{OL} = (256/V_{CC}) \cdot (V_{out}) \cdot (V_{CC} - V_{out})$, for $0 < V_{out} < 0.18V_{CC}$

10.4 Timing Specifications

10.4.1 Clocks Specifications

10.4.1.1 PCI Clock Specifications

The 82559ER uses the PCI Clock signal directly. Figure 26 shows the clock waveform and required measurement points for the PCI Clock signal. Table 21 summarizes the PCI Clock specifications.

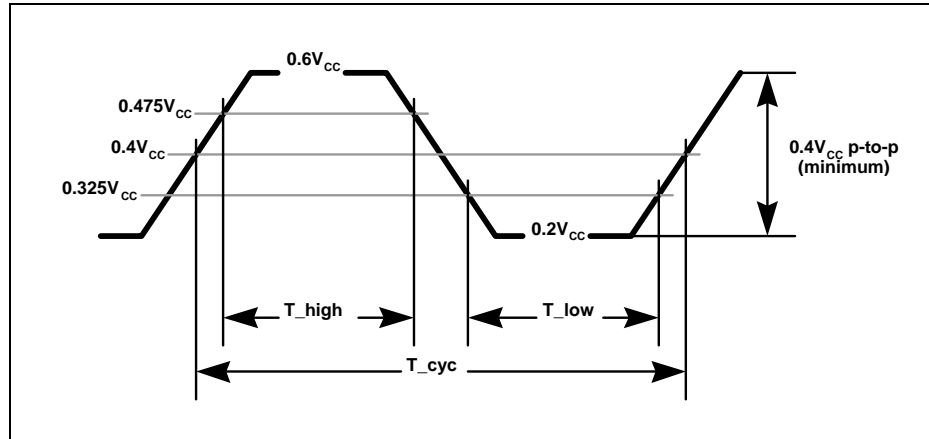

Figure 26. PCI/CardBus Clock Waveform

Table 21. PCI/CardBus Clock Specifications

	Symbol	Parameter	Min	Max	Units	Notes
T1	T_{cyc}	CLK Cycle Time	30		ns	1
T2	T_{high}	CLK High Time	11		ns	
T3	T_{low}	CLK Low Time	11		ns	
T4	T_{slew}	CLK Slew Rate	1	4	V/ns	2

NOTES:

1. The 82559ER will work with any PCI clock frequency up to 33 MHz.
2. Rise and fall times are specified in terms of the edge rate measured in V/ns. This slew rate is met across the minimum peak-to-peak portion of the clock waveform as shown in Figure 26.

10.4.1.2 X1 Specifications

X1 serves as a signal input from an external crystal or oscillator. Table 22 defines the 82559ER requirements from this signal.

Table 22. X1 Clock Specifications

	Symbol	Parameter	Min	Typical	Max	Units	Notes
T8	Tx1_dc	X1 Duty Cycle	40%		60%		
T9	Tx1_pr	X1 Period		40		ns	±50PPM

10.4.2 Timing Parameters

10.4.2.1 Measurement and Test Conditions

Figure 27, Figure 28, and Table 23 define the conditions under which timing measurements are done. The component test guarantees that all timings are met with minimum clock slew rate (slowest edge) and voltage swing. The design must guarantee that minimum timings are also met with maximum clock slew rate (fastest edge) and voltage swing. In addition, the design must guarantee proper input operation for input voltage swings and slew rates that exceed the specified test conditions.

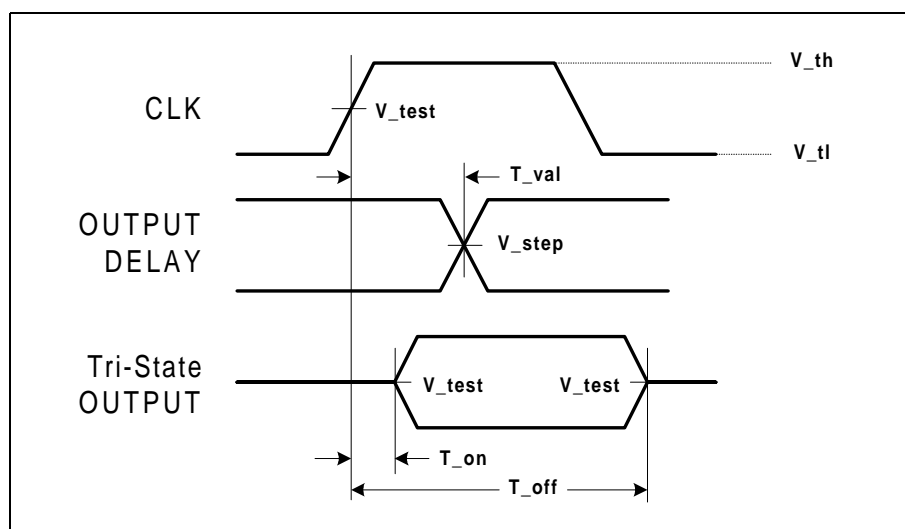

Figure 27. Output Timing Measurement Conditions

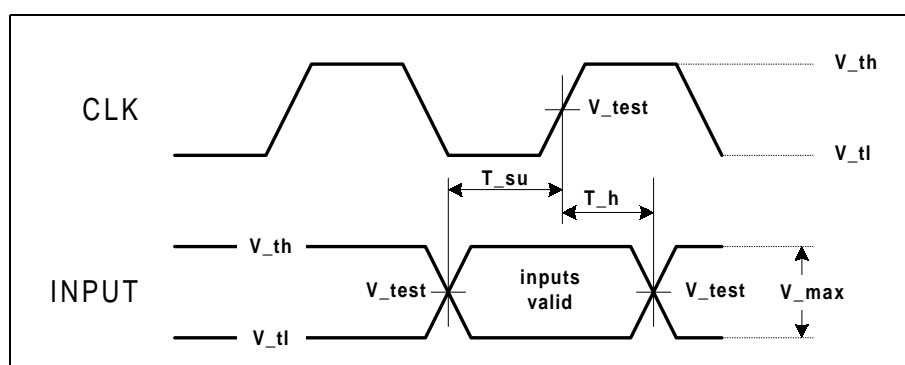

Figure 28. Input Timing Measurement Conditions

Table 23. Measure and Test Condition Parameters

Symbol	PCI Level	CardBus Level	Units	Notes
V_{th}	$0.6V_{CC}$	$0.6V_{CC}$	V	
V_{tl}	$0.2V_{CC}$	$0.2V_{CC}$	V	
V_{test}	$0.4V_{CC}$	$0.4V_{CC}$	V	

Table 23. Measure and Test Condition Parameters

V_{step} (rising edge)	$0.285V_{\text{CC}}$	$0.325V_{\text{CC}}$	V	Min Delay
		$0.475V_{\text{CC}}$	V	Max Delay
V_{step} (falling edge)	$0.615V_{\text{CC}}$	$0.475V_{\text{CC}}$	V	Min Delay
		$0.325V_{\text{CC}}$	V	Max Delay
V_{max}	$0.4V_{\text{CC}}$	$0.4V_{\text{CC}}$	V	
Input Signal Edge Rate	1	1	V/ns	

NOTE: Input test is done with $0.1V_{\text{CC}}$ overdrive. V_{max} specifies the maximum peak-to-peak waveform allowed for testing input timing.

10.4.2.2 PCI Timings

Table 24. PCI Timing Parameters

	Symbol	Parameter	Min	Max	Units	Notes
T14	t_{val}	PCI CLK to Signal Valid Delay	2	11	ns	1, 2, 4
T15	$t_{\text{val(ptp)}}$	PCI CLK to Signal Valid Delay (point-to-point)	2	12	ns	1, 2, 4
T16	t_{on}	Float to Active Delay	2		ns	1
T17	t_{off}	Active to Float Delay		28	ns	1
T18	t_{su}	Input Setup Time to CLK	7		ns	4, 5
T19	$t_{\text{su(ptp)}}$	PCI Input Setup Time to CLK (point-to-point)	10		ns	4, 5
T20	t_{h}	Input Hold Time from CLK	0		ns	6
T21	t_{rst}	Reset Active Time After Power Stable	1		ms	6
T22	$T_{\text{rst-clk}}$	PCI Reset Active Time After CLK Stable	100		μs	6
T23	$T_{\text{rst-off}}$	Reset Active to Output Float Delay		40	ns	6, 7

NOTES:

- Timing measurement conditions are illustrated in [Figure 27](#).
- PCI minimum times are specified with loads as detailed in the PCI Bus Specification, Revision 2.1, Section 4.2.3.2.
- In a PCI environment, REQ# and GNT# are point-to-point signals and have different output valid delay times and input setup times than bussed signals. All other signals are bussed.
- Timing measurement conditions are illustrated in [Figure 28](#).
- RST# is asserted and de-asserted asynchronously with respect to the CLK signal.
- All PCI interface output drivers are floated when RST# is active.

10.4.2.3 Flash Interface Timings

The 82559ER is designed to support up to 150 nanoseconds of Flash access time. The V_{PP} signal in the Flash implementation should be connected permanently to 12 V. Thus, writing to the Flash is controlled only by the FLWE# pin.

[Table 25](#) provides the timing parameters for the Flash interface signals. The timing parameters are illustrated in [Figure 29](#) and [Figure 30](#).

Table 25. Flash Timing Parameters

	Symbol	Parameter	Min	Max	Units	Notes
T35	t_{flrwc}	Flash Read/Write Cycle Time	150		ns	1, Flash t_{AVAV} = 150 ns
T36	t_{flacc}	FLA to Read FLD Setup Time	150		ns	1, Flash t_{AVQV} = 150 ns
T37	t_{flce}	FLCS# to Read FLD Setup Time	150		ns	1, Flash t_{ELQV} = 150 ns
T38	t_{floec}	FLOE# Active to Read FLD Setup Time	120		ns	1, Flash t_{GLQV} = 55 ns
T39	t_{fldf}	FLOE# Inactive to FLD Driven Delay Time	50		ns	1, Flash t_{GHQZ} = 35 ns
T40	t_{flas}	FLA Setup Time before FLWE#	5		ns	2, Flash t_{AVWL} = 0 ns
T41	t_{flah}	FLA Hold Time after FLWE#	200		ns	2, Flash t_{WLAX} = 60 ns
T42	t_{flcs}	FLCS# Hold Time before FLWE#	30		ns	2, Flash t_{ELWL} = 20 ns
T43	t_{flch}	FLCS# Hold Time after FLWE#	30		ns	2, Flash t_{WHEH} = 0 ns
T44	t_{flds}	FLD Setup Time	150		ns	2, Flash t_{DVWH} = 50 ns
T45	t_{fldh}	FLD Hold Time	10		ns	2, Flash t_{WHDX} = 10 ns
T46	t_{flwp}	Write Pulse Width	120		ns	2, Flash t_{WLWH} = 60 ns
T47	t_{flwph}	Write Pulse Width High	25		ns	2, Flash t_{WHWL} = 20 ns
T48	t_{Mioha}	IOCHRDY Hold Time after FLWE# or FLOE# Active		25	ns	
T49	t_{Miohi}	IOCHRDY Hold Time after FLWE# or FLOE# Inactive	0		ns	

NOTES:

1. These timing specifications apply to Flash read cycles. The Flash timings referenced are 28F020-150 timings.
2. These timing specifications apply to Flash write cycles. The Flash timings referenced are 28F020-150 timings.

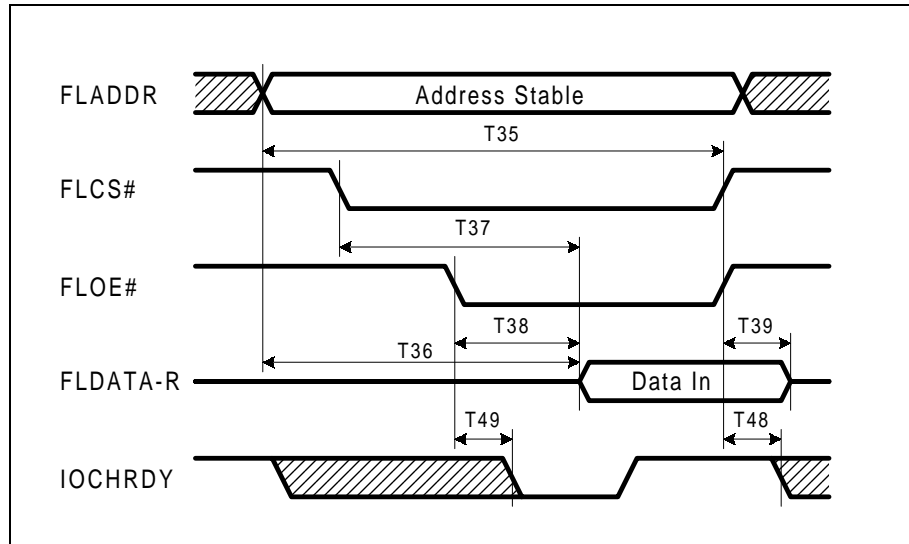

Figure 29. Flash Timings for a Read Cycle

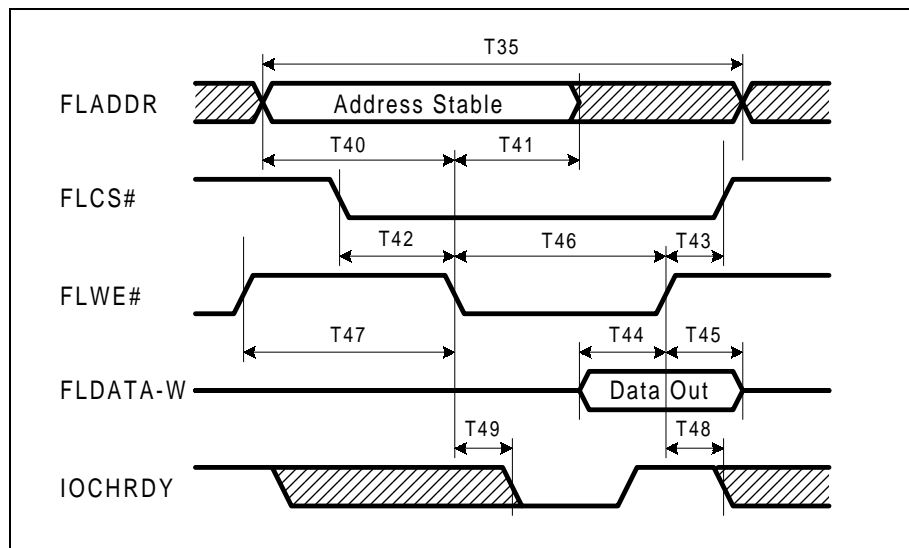

Figure 30. Flash Timings for a Write Cycle

10.4.2.4 EEPROM Interface Timings

The 82559ER is designed to support a standard 64x16 or 256x16 serial EEPROM. Table 26 provides the timing parameters for the EEPROM interface signals. The timing parameters are illustrated in Figure 31.

Table 26. EEPROM Timing Parameters

	Symbol	Parameter	Min	Max	Units	Notes
T50	t_{EFSK}	Serial Clock Frequency		1	Mhz	EEPROM fsk = 1 MHz
T51	t_{ECSS}	Delay from EECS High to EESK High	300		ns	EEPROM tc _{ss} = 50 ns
T52	t_{ECSH}	Delay from EESK Low to EECS Low	30		ns	EEPROM tc _{sh} = 0 ns
T53	t_{EDIS}	Setup Time of EEDI to EESK	300		ns	EEPROM td _{is} = 150 ns
T54	t_{EDIH}	Hold Time of EEDI after EESK	300		ns	EEPROM td _{ih} = 150 ns
T55	t_{ECS}	EECS Low Time	750		ns	EEPROM tc _s = 250 ns

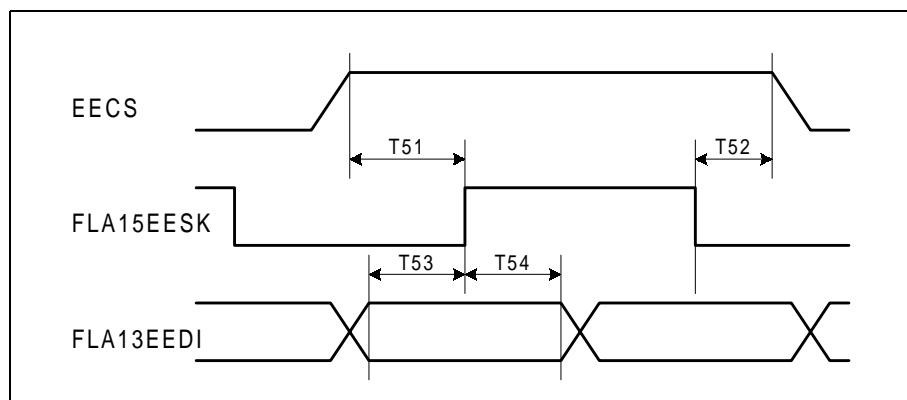

Figure 31. EEPROM Timings

10.4.2.5 PHY Timings

Table 27. 10BASE-T NLP Timing Parameters

	Symbol	Parameter	Condition	Min	Typ	Max	Units
T56	T_{nlp_wid}	NLP Width	10 Mbps		100		ns
T57	T_{nlp_per}	NLP Period	10 Mbps	8		24	ms

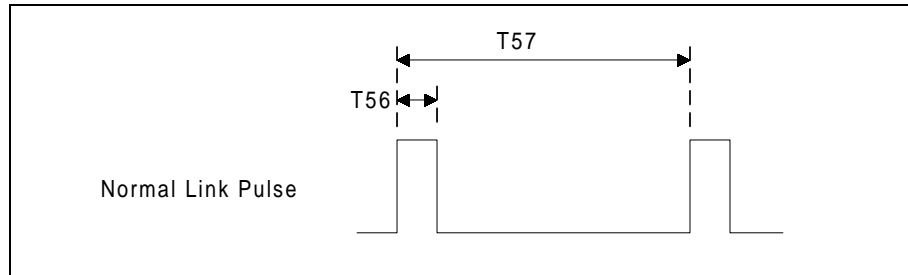

Figure 32. 10BASE-T NLP Timings

Table 28. Auto-Negotiation FLP Timing Parameters

	Symbol	Parameter	Min	Typ	Max	Units
T58	T_{flp_wid}	FLP Width (clock/data)		100		ns
T59	$T_{flp_clk_clk}$	Clock Pulse to Clock Pulse Period	111	125	139	μ s
T60	$T_{flp_clk_dat}$	Clock Pulse to Data Pulse Period	55.5	62.5	69.5	μ s
T61	$T_{flp_bur_num}$	Number of Pulses in one burst	17		33	
T62	$T_{flp_bur_wid}$	FLP Burst Width		2		ms
T63	$T_{flp_bur_per}$	FLP Burst Period	8		24	ms

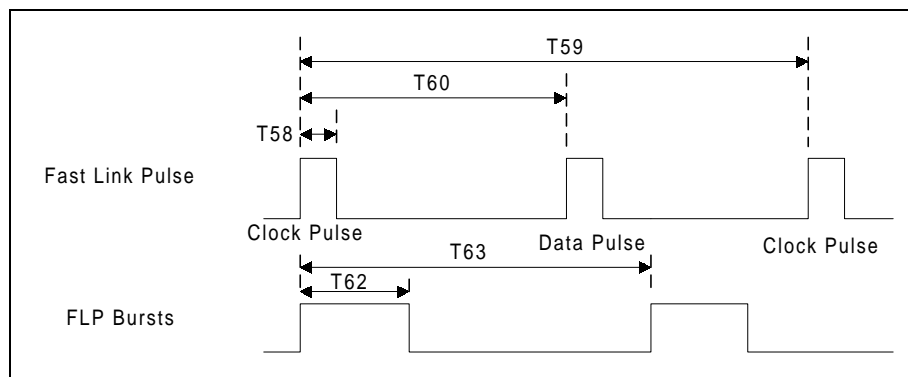

Figure 33. Auto-Negotiation FLP Timings

Table 29. 100Base-TX Transmitter AC Specification

	Symbol	Parameter	Condition	Min	Typ	Max	Units
T64	T_{jit}	TDP/TDN Differential Output Peak Jitter	HLS Data			1400	ps

11.0 Package and Pinout Information

11.1 Package Information

The 82559ER is a 196-pin Ball Grid Array (BGA) package. Package dimensions are shown in Figure 34. More information on Intel device packaging is available in the Intel Packaging Handbook, which is available from the Intel Literature Center or your local Intel sales office.

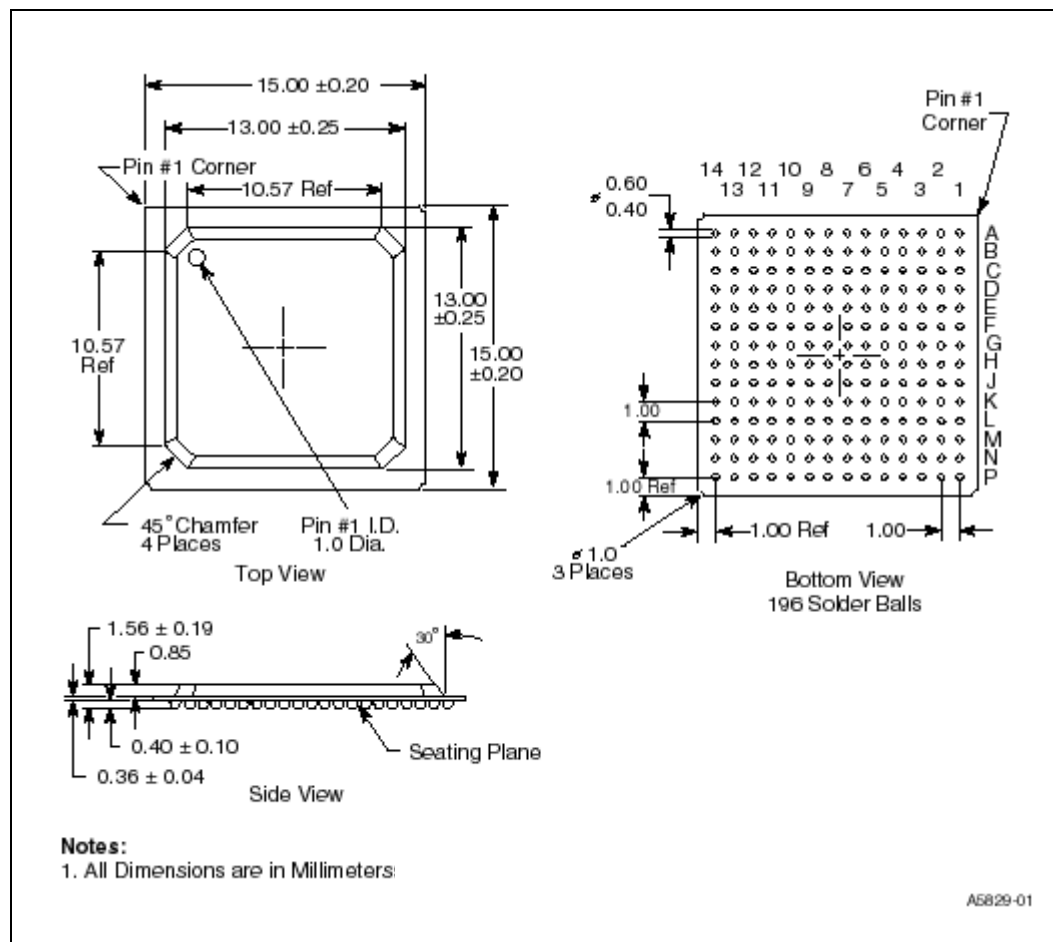

Figure 34. Dimension Diagram for the 82559ER 196-Pin BGA

11.2 Pinout Information

11.2.1 82559ER Pin Assignments

Table 30. 82559ER Pin Assignments

Pin	Name	Pin	Name	Pin	Name
A1	NC	A2	SERR#	A3	VCC
A4	IDSEL	A5	AD25	A6	PME#
A7	VCC	A8	AD30	A9	ALTRST#
A10	NC	A11	VCC	A12	LILED
A13	TEST	A14	NC		
B1	AD22	B2	AD23	B3	VSSPP
B4	AD24	B5	AD26	B6	AD27
B7	VSSPP	B8	AD31	B9	ISOLATE#
B10	NC	B11	SPEEDLED	B12	TO
B13	RBIAS100	B14	RBIAS10		
C1	AD21	C2	RST#	C3	REQ#
C4	C/BE3#	C5	NC	C6	AD28
C7	AD29	C8	CLKRUN#	C9	NC
C10	VSSPT	C11	ACTLED	C12	VREF
C13	TDP	C14	TDN		
D1	AD18	D2	AD19	D3	AD20
D4	VSS	D5	VSS	D6	VSS
D7	VSS	D8	VSS	D9	NC
D10	NC	D11	VSS	D12	TI
D13	TEXEC	D14	TCK		
E1	VCC	E2	VSSPP	E3	AD17
E4	VSS	E5	VSS	E6	VSS
E7	VSS	E8	VSS	E9	VSS
E10	VSS	E11	VSS	E12	VCC
E13	RDP	E14	RDN		
F1	IRDY#	F2	FRAME#	F3	C/BE2#
F4	VSS	F5	VSS	F6	VSS
F7	VSS	F8	VSS	F9	VSS
F10	VSS	F11	VSS	F12	FLD2
F13	FLD1	F14	FLD0		
G1	CLK	G2	VIO	G3	TRDY#
G4	NC	G5	VCC	G6	VCC
G7	VSS	G8	VSS	G9	VSS
G10	VSS	G11	VSS	G12	FLD3
G13	VCC	G14	VSSPL		

Table 30. 82559ER Pin Assignments

Pin	Name	Pin	Name	Pin	Name
H1	STOP#	H2	INTA#	H3	DEVSEL#
H4	NC	H5	VCC	H6	VCC
H7	VCC	H8	VCC	H9	VSS
H10	VSS	H11	VSS	H12	FLD6
H13	FLD5	H14	FLD4		
J1	PAR	J2	PERR#	J3	GNT#
J4	NC	J5	VCC	J6	VCC
J7	VCC	J8	VCC	J9	VCC
J10	VCC	J11	VCC	J12	FLA1
J13	FLA0	J14	FLD7		
K1	AD16	K2	VSSPP	K3	VCC
K4	VCC	K5	VCC	K6	VCC
K7	VCC	K8	VCC	K9	VCC
K10	VCC	K11	VCC	K12	VSSPL
K13	VCC	K14	FLA2		
L1	AD14	L2	AD15	L3	C/BE#1
L4	VCC	L5	VCC	L6	VSS
L7	NC	L8	NC	L9	VCC
L10	VCC	L11	VSS	L12	FLA5
L13	FLA4	L14	FLA3		
M1	AD11	M2	AD12	M3	AD13
M4	C/BE0#	M5	AD5	M6	VSSPP
M7	AD1	M8	FLOE#	M9	FLWE#
M10	FLA15/EESK	M11	FLA12	M12	FLA11
M13	FLA7	M14	FLA6		
N1	VSSPP	N2	AD10	N3	AD9
N4	AD7	N5	AD4	N6	VCC
N7	AD0	N8	VCC	N9	FLCS#
N10	FLA14/EEDO	N11	X1	N12	VSSPL
N13	FLA10	N14	FLA8		
P1	NC	P2	VCC	P3	AD8
P4	AD6	P5	AD3	P6	AD2
P7	EECS	P8	VSSPL	P9	FLA16
P10	FLA13/EEDI	P11	X2	P12	VCC
P13	FLA9	P14	NC		

11.2.2 82559ER Ball Grid Array Diagram

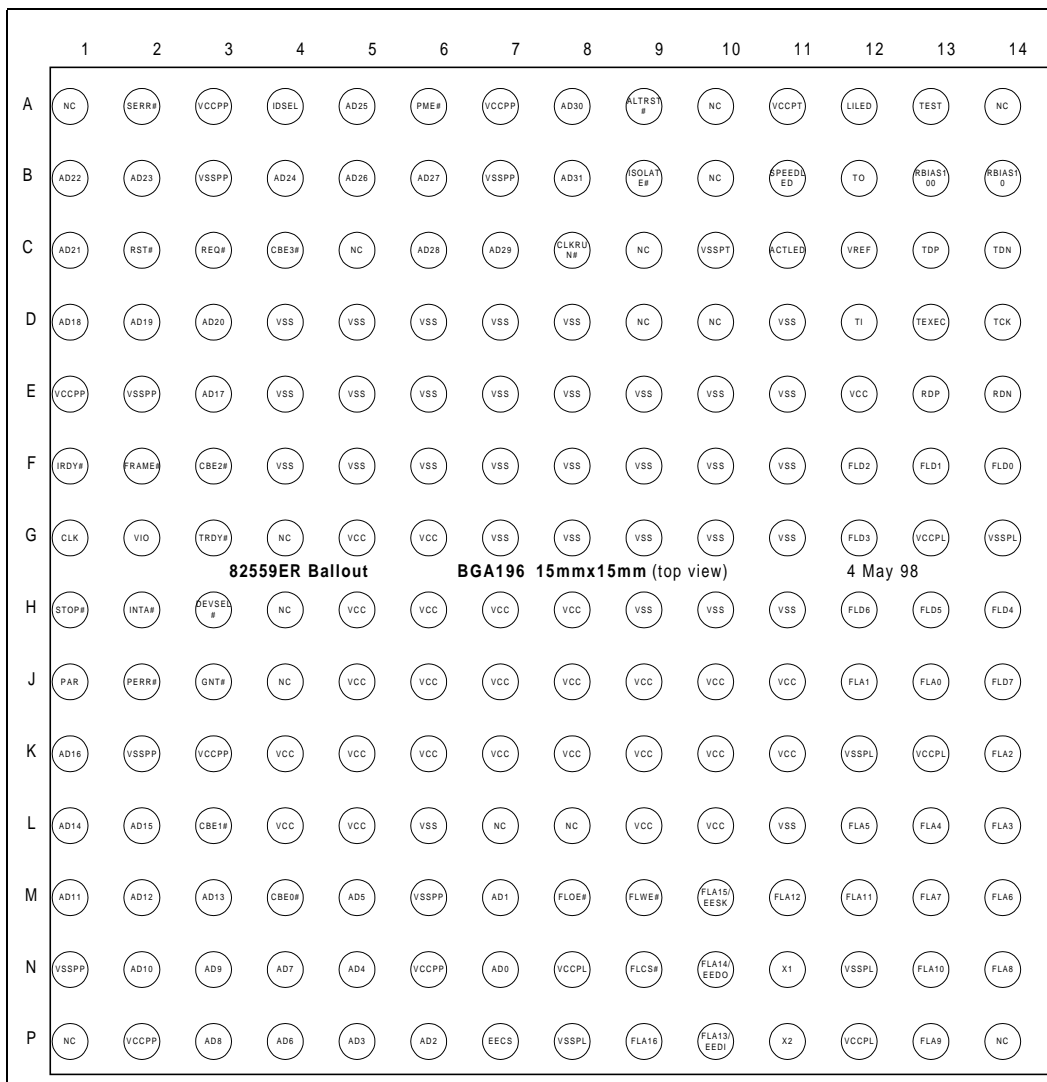

Figure 35. 82559ER Ball Grid Array Diagram