

MAX809 Series, MAX810 Series

Very Low Supply Current 3-Pin Microprocessor Reset Monitors

The MAX809 and MAX810 are cost-effective system supervisor circuits designed to monitor V_{CC} in digital systems and provide a reset signal to the host processor when necessary. No external components are required.

The reset output is driven active within 10 μ sec of V_{CC} falling through the reset voltage threshold. Reset is maintained active for a timeout period which is trimmed by the factory after V_{CC} rises above the reset threshold. The MAX810 has an active-high RESET output while the MAX809 has an active-low $\overline{\text{RESET}}$ output. Both devices are available in SOT-23 and SC-70 packages.

The MAX809/810 are optimized to reject fast transient glitches on the V_{CC} line. Low supply current of 0.5 μ A ($V_{CC} = 3.2$ V) makes these devices suitable for battery powered applications.

Features

- Precision V_{CC} Monitor for 1.5 V, 1.8 V, 2.5 V, 3.0 V, 3.3 V, and 5.0 V Supplies
- Precision Monitoring Voltages from 1.2 V to 4.9 V Available in 100 mV Steps
- Four Guaranteed Minimum Power-On Reset Pulse Width Available (1 ms, 20 ms, 100 ms, and 140 ms)
- $\overline{\text{RESET}}$ Output Guaranteed to $V_{CC} = 1.0$ V.
- Low Supply Current
- Compatible with Hot Plug Applications
- V_{CC} Transient Immunity
- No External Components
- Wide Operating Temperature: -40°C to 105°C
- Pb-Free Packages are Available

Typical Applications

- Computers
- Embedded Systems
- Battery Powered Equipment
- Critical Microprocessor Power Supply Monitoring

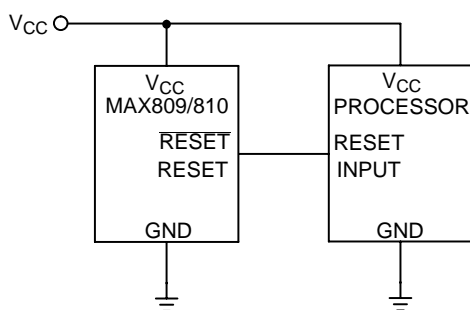

Figure 1. Typical Application Diagram



ON Semiconductor®

<http://onsemi.com>

MARKING DIAGRAM

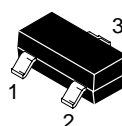

SOT-23
(TO-236)
CASE 318

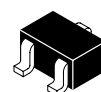
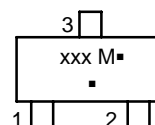

SC-70
(SOT-323)
CASE 419

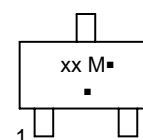

xxx = Specific Device Code
M = Date Code
▪ = Pb-Free Package
(Note: Microdot may be in either location)

PIN CONFIGURATION

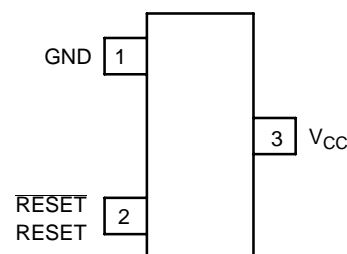

SOT-23/SC-70
(Top View)

NOTE: $\overline{\text{RESET}}$ is for MAX809
RESET is for MAX810

ORDERING INFORMATION

See detailed ordering and shipping information in the package dimensions section on page 8 of this data sheet.

DEVICE MARKING INFORMATION

See general marking information in the device marking section on page 8 of this data sheet.

MAX809 Series, MAX810 Series

PIN DESCRIPTION

Pin No.	Symbol	Description
1	GND	Ground
2	RESET (MAX809)	RESET output remains low while V _{CC} is below the reset voltage threshold, and for a reset timeout period after V _{CC} rises above reset threshold
2	RESET (MAX810)	RESET output remains high while V _{CC} is below the reset voltage threshold, and for a reset timeout period after V _{CC} rises above reset threshold
3	V _{CC}	Supply Voltage (Typ)

ABSOLUTE MAXIMUM RATINGS

Rating	Symbol	Value	Unit
Power Supply Voltage (V _{CC} to GND)	V _{CC}	-0.3 to 6.0	V
RESET Output Voltage (CMOS)		-0.3 to (V _{CC} + 0.3)	V
Input Current, V _{CC}		20	mA
Output Current, RESET		20	mA
dV/dt (V _{CC})		100	V/μsec
Thermal Resistance, Junction-to-Air (Note 1)	SOT-23 SC-70	R _{θJA} 301 314	°C/W
Operating Junction Temperature Range	T _J	-40 to +105	°C
Storage Temperature Range	T _{stg}	-65 to +150	°C
Lead Temperature (Soldering, 10 Seconds)	T _{sol}	+260	°C
ESD Protection Human Body Model (HBM): Following Specification JESD22-A114 Machine Model (MM): Following Specification JESD22-A115		2000 200	V
Latchup Current Maximum Rating: Following Specification JESD78 Class II Positive Negative	I _{Latchup}	200 200	mA

Maximum ratings are those values beyond which device damage can occur. Maximum ratings applied to the device are individual stress limit values (not normal operating conditions) and are not valid simultaneously. If these limits are exceeded, device functional operation is not implied, damage may occur and reliability may be affected.

1. This based on a 35x35x1.6mm FR4 PCB with 10mm² of 1 oz copper traces under natural convection conditions and a single component characterization.
2. The maximum package power dissipation limit must not be exceeded.

$$P_D = \frac{T_{J(max)} - T_A}{R_{\theta JA}} \quad \text{with } T_{J(max)} = 150^\circ\text{C}$$

MAX809 Series, MAX810 Series

ELECTRICAL CHARACTERISTICS $T_A = -40^\circ\text{C}$ to $+105^\circ\text{C}$ unless otherwise noted. Typical values are at $T_A = +25^\circ\text{C}$. (Note 3)

Characteristic	Symbol	Min	Typ	Max	Unit
V_{CC} Range $T_A = 0^\circ\text{C}$ to $+70^\circ\text{C}$ $T_A = -40^\circ\text{C}$ to $+105^\circ\text{C}$		1.0 1.2	– –	5.5 5.5	V
Supply Current $V_{CC} = 3.3\text{ V}$ $T_A = -40^\circ\text{C}$ to $+85^\circ\text{C}$ $T_A = 85^\circ\text{C}$ to $+105^\circ\text{C}$ $V_{CC} = 5.5\text{ V}$ $T_A = -40^\circ\text{C}$ to $+85^\circ\text{C}$ $T_A = 85^\circ\text{C}$ to $+105^\circ\text{C}$	I_{CC}	– – – –	0.5 – – –	1.2 2.0 1.8 2.5	μA
Reset Threshold (V_{in} Decreasing) (Note 4)	V_{TH}				V
MAX809SN490 $T_A = +25^\circ\text{C}$ $T_A = -40^\circ\text{C}$ to $+85^\circ\text{C}$ $T_A = +85^\circ\text{C}$ to $+105^\circ\text{C}$		4.83 4.78 4.66	4.9 – –	4.97 5.02 5.14	
MAX8xxLTR, MAX8xxSQ463 $T_A = +25^\circ\text{C}$ $T_A = -40^\circ\text{C}$ to $+85^\circ\text{C}$ $T_A = +85^\circ\text{C}$ to $+105^\circ\text{C}$		4.56 4.50 4.40	4.63 – –	4.70 4.75 4.86	
MAX809HTR $T_A = +25^\circ\text{C}$ $T_A = -40^\circ\text{C}$ to $+85^\circ\text{C}$ $T_A = +85^\circ\text{C}$ to $+105^\circ\text{C}$		4.48 4.43 4.32	4.55	4.62 4.67 4.78	
MAX8xxMTR, MAX8xxSQ438 $T_A = +25^\circ\text{C}$ $T_A = -40^\circ\text{C}$ to $+85^\circ\text{C}$ $T_A = +85^\circ\text{C}$ to $+105^\circ\text{C}$		4.31 4.27 4.16	4.38	4.45 4.49 4.60	
MAX809JTR $T_A = +25^\circ\text{C}$ $T_A = -40^\circ\text{C}$ to $+85^\circ\text{C}$ $T_A = +85^\circ\text{C}$ to $+105^\circ\text{C}$		3.94 3.90 3.80	4.00 – –	4.06 4.10 4.20	
MAX8xxTTR, MAX809SQ308 $T_A = +25^\circ\text{C}$ $T_A = -40^\circ\text{C}$ to $+85^\circ\text{C}$ $T_A = +85^\circ\text{C}$ to $+105^\circ\text{C}$		3.04 3.00 2.92	3.08 – –	3.11 3.16 3.24	
MAX8xxSTR, MAX8xxSQ293 $T_A = +25^\circ\text{C}$ $T_A = -40^\circ\text{C}$ to $+85^\circ\text{C}$ $T_A = +85^\circ\text{C}$ to $+105^\circ\text{C}$		2.89 2.85 2.78	2.93 – –	2.96 3.00 3.08	
MAX8xxRTR, MAX8xxSQ263 $T_A = +25^\circ\text{C}$ $T_A = -40^\circ\text{C}$ to $+85^\circ\text{C}$ $T_A = +85^\circ\text{C}$ to $+105^\circ\text{C}$		2.59 2.56 2.49	2.63 – –	2.66 2.70 2.77	
MAX809SN232, MAX809SQ232 $T_A = +25^\circ\text{C}$ $T_A = -40^\circ\text{C}$ to $+85^\circ\text{C}$ $T_A = +85^\circ\text{C}$ to $+105^\circ\text{C}$		2.28 2.25 2.21	2.32 – –	2.35 2.38 2.45	
MAX809SN160 $T_A = +25^\circ\text{C}$ $T_A = -40^\circ\text{C}$ to $+85^\circ\text{C}$ $T_A = +85^\circ\text{C}$ to $+105^\circ\text{C}$		1.58 1.56 1.52	1.60 – –	1.62 1.64 1.68	
MAX809SN120, MAX8xxSQ120 $T_A = +25^\circ\text{C}$ $T_A = -40^\circ\text{C}$ to $+85^\circ\text{C}$ $T_A = +85^\circ\text{C}$ to $+105^\circ\text{C}$		1.18 1.17 1.14	1.20 – –	1.22 1.23 1.26	

3. Production testing done at $T_A = 25^\circ\text{C}$, over temperature limits guaranteed by design.

4. Contact your ON Semiconductor sales representative for other threshold voltage options.

MAX809 Series, MAX810 Series

ELECTRICAL CHARACTERISTICS (continued) $T_A = -40^{\circ}\text{C}$ to $+105^{\circ}\text{C}$ unless otherwise noted. Typical values are at $T_A = +25^{\circ}\text{C}$. (Note 5)

Characteristic	Symbol	Min	Typ	Max	Unit
Detector Voltage Threshold Temperature Coefficient		–	30	–	ppm/ $^{\circ}\text{C}$
V_{CC} to Reset Delay $V_{CC} = V_{TH}$ to $(V_{TH} - 100\text{ mV})$		–	10	–	μsec
Reset Active TimeOut Period (Note 6) MAX8xxSN(Q)293D1 MAX8xxSN(Q)293D2 MAX8xxSN(Q)293D3 MAX8xxSN(Q)293	t_{RP}	1.0 20 100 140	– – – –	3.3 66 330 460	msec
RESET Output Voltage Low (No Load) (MAX809) $V_{CC} = V_{TH} - 0.2\text{ V}$ $1.6\text{ V} \leq V_{TH} \leq 2.0\text{ V}$, $I_{SINK} = 0.5\text{ mA}$ $2.1\text{ V} \leq V_{TH} \leq 4.0\text{ V}$, $I_{SINK} = 1.2\text{ mA}$ $4.1\text{ V} \leq V_{TH} \leq 4.9\text{ V}$, $I_{SINK} = 3.2\text{ mA}$	V_{OL}	–	–	0.3	V
RESET Output Voltage High (No Load) (MAX809) $V_{CC} = V_{TH} + 0.2\text{ V}$ $1.6\text{ V} \leq V_{TH} \leq 2.4\text{ V}$, $I_{SOURCE} = 200\text{ }\mu\text{A}$ $2.5\text{ V} \leq V_{TH} \leq 4.9\text{ V}$, $I_{SOURCE} = 500\text{ }\mu\text{A}$	V_{OH}	$0.8 V_{CC}$	–	–	V
RESET Output Voltage High (No Load) (MAX810) $V_{CC} = V_{TH} + 0.2\text{ V}$ $1.6\text{ V} \leq V_{TH} \leq 2.4\text{ V}$, $I_{SOURCE} = 200\text{ }\mu\text{A}$ $2.5\text{ V} \leq V_{TH} \leq 4.9\text{ V}$, $I_{SOURCE} = 500\text{ }\mu\text{A}$	V_{OH}	$0.8 V_{CC}$	–	–	V
RESET Output Voltage Low (No Load) (MAX810) $V_{CC} = V_{TH} - 0.2\text{ V}$ $1.6\text{ V} \leq V_{TH} \leq 2.0\text{ V}$, $I_{SINK} = 0.5\text{ mA}$ $2.1\text{ V} \leq V_{TH} \leq 4.0\text{ V}$, $I_{SINK} = 1.2\text{ mA}$ $4.1\text{ V} \leq V_{TH} \leq 4.9\text{ V}$, $I_{SINK} = 3.2\text{ mA}$	V_{OL}	–	–	0.3	V

5. Production testing done at $T_A = 25^{\circ}\text{C}$, over temperature limits guaranteed by design.
6. Contact your ON Semiconductor sales representative for timeout options availability for other threshold voltage options.

MAX809 Series, MAX810 Series

TYPICAL OPERATING CHARACTERISTICS

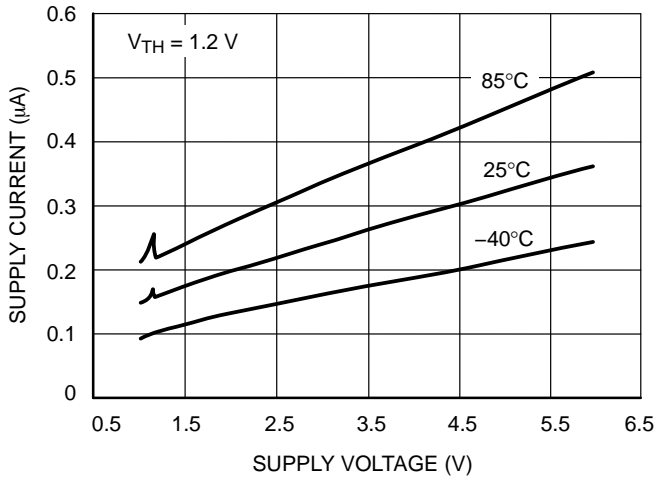

Figure 2. Supply Current vs. Supply Voltage

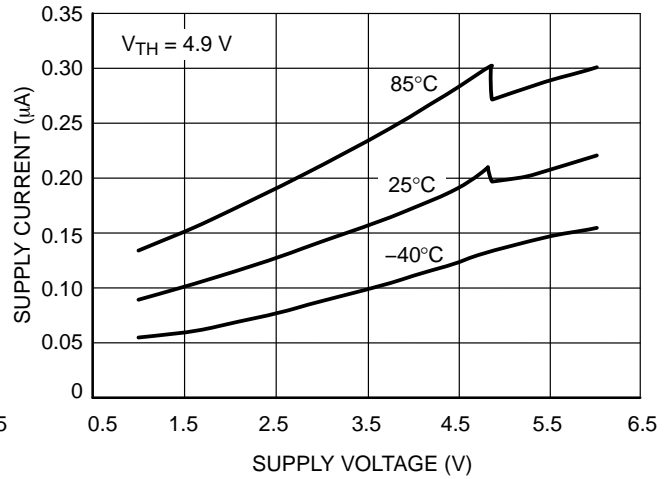

Figure 3. Supply Current vs. Supply Voltage

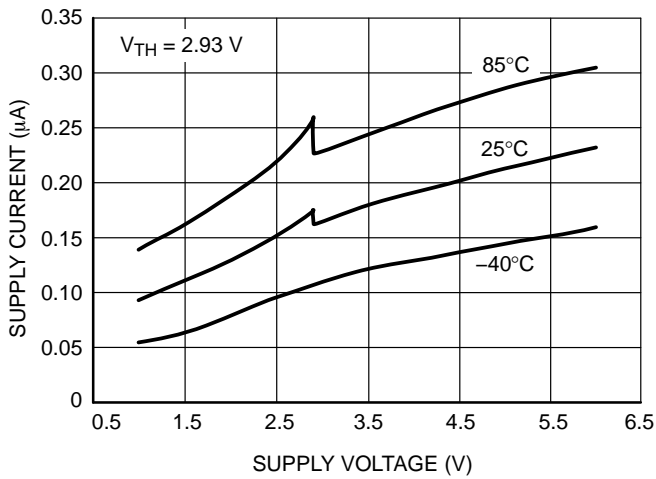

Figure 4. Supply Current vs. Supply Voltage

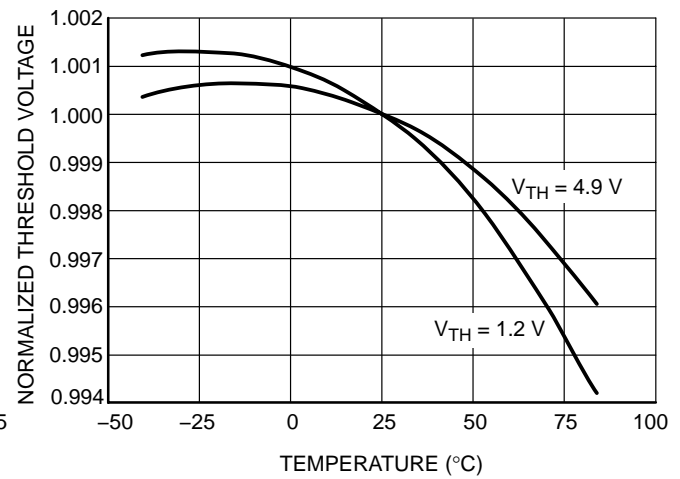

Figure 5. Normalized Reset Threshold Voltage vs. Temperature

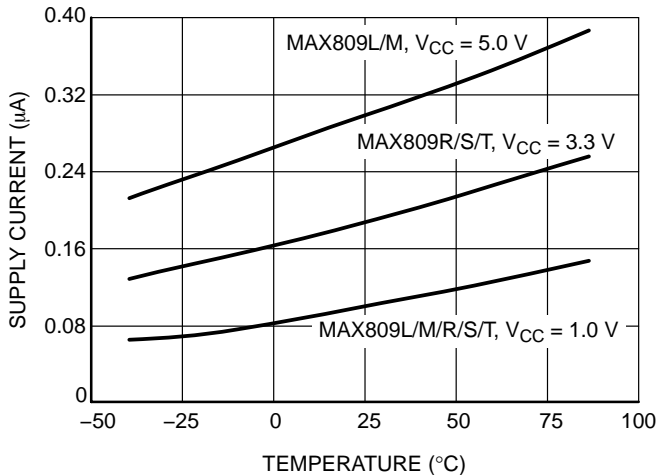

Figure 6. Supply Current vs. Temperature (No Load, MAX809)

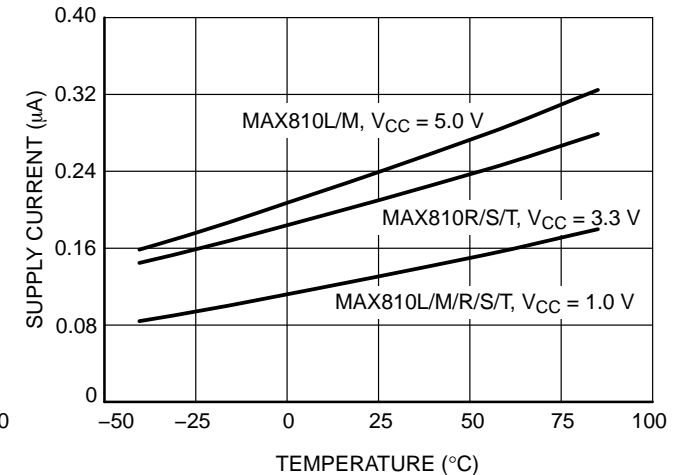

Figure 7. Supply Current vs. Temperature (No Load, MAX810)

MAX809 Series, MAX810 Series

TYPICAL OPERATING CHARACTERISTICS

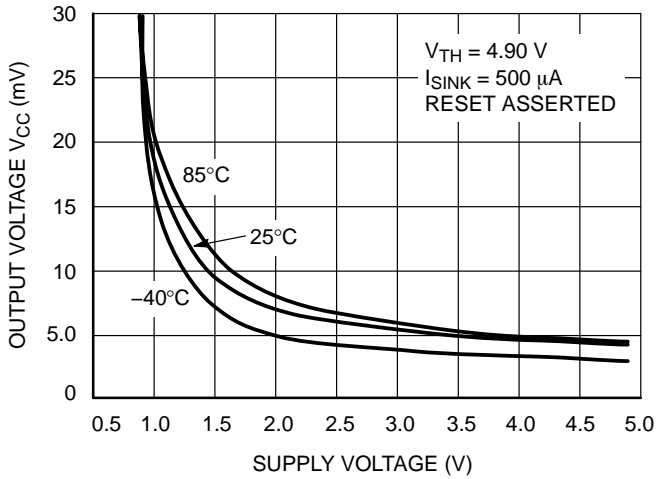

Figure 8. Output Voltage Low vs. Supply Voltage

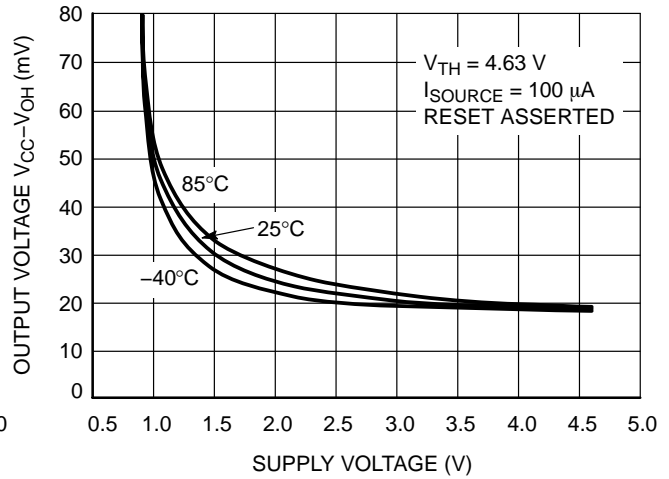

Figure 9. Output Voltage High vs. Supply Voltage

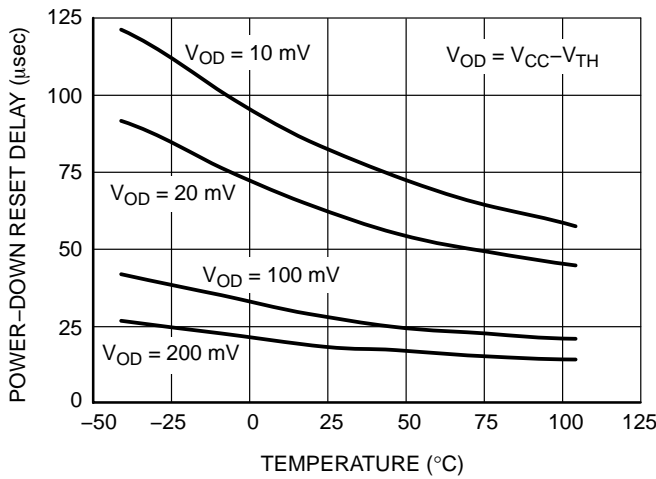

Figure 10. Power-Down Reset Delay vs. Temperature and Overdrive ($V_{TH} = 1.2 V$)

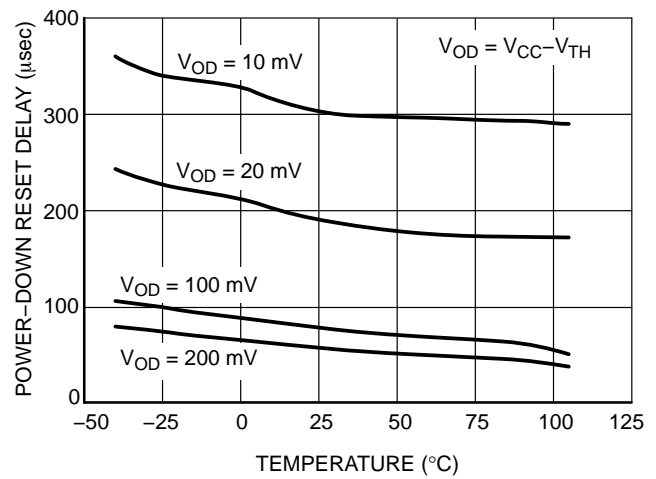

Figure 11. Power-Down Reset Delay vs. Temperature and Overdrive ($V_{TH} = 4.9 V$)

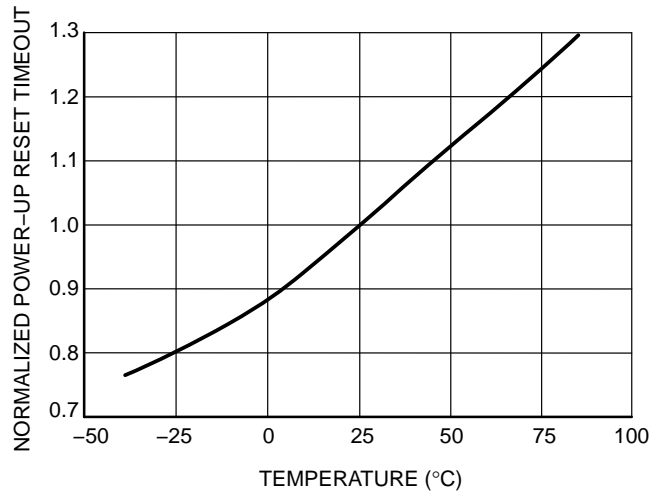

Figure 12. Normalized Power-Up Reset vs. Temperature

APPLICATIONS INFORMATION

V_{CC} Transient Rejection

The MAX809 provides accurate V_{CC} monitoring and reset timing during power-up, power-down, and brownout/sag conditions, and rejects negative-going transients (glitches) on the power supply line. Figure 13 shows the maximum transient duration vs. maximum negative excursion (overdrive) for glitch rejection. Any combination of duration and overdrive which lies **under** the curve will **not** generate a reset signal. Combinations above the curve are detected as a brownout or power-down. Typically, transient that goes 100 mV below the reset threshold and lasts 5.0 μs or less will not cause a reset pulse. Transient immunity can be improved by adding a capacitor in close proximity to the V_{CC} pin of the MAX809.

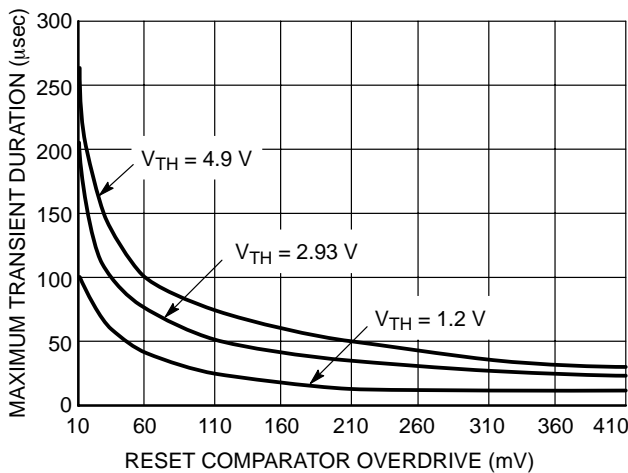
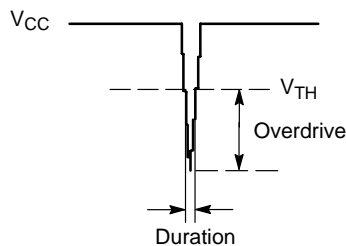

Figure 13. Maximum Transient Duration vs. Overdrive for Glitch Rejection at 25°C

RESET Signal Integrity During Power-Down

The MAX809 RESET output is valid to V_{CC} = 1.0 V. Below this voltage the output becomes an “open circuit” and does not sink current. This means CMOS logic inputs to the Microprocessor will be floating at an undetermined voltage. Most digital systems are completely shutdown well above this voltage. However, in situations where RESET must be

maintained valid to V_{CC} = 0 V, a pull-down resistor must be connected from RESET to ground to discharge stray capacitances and hold the output low (Figure 14). This resistor value, though not critical, should be chosen such that it does not appreciably load RESET under normal operation (100 kΩ will be suitable for most applications).

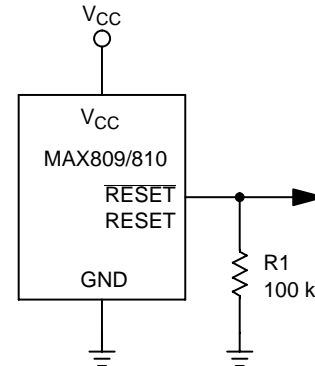

Figure 14. Ensuring RESET Valid to V_{CC} = 0 V

Processors With Bidirectional I/O Pins

Some Microprocessor's have bidirectional reset pins. Depending on the current drive capability of the processor pin, an indeterminate logic level may result if there is a logic conflict. This can be avoided by adding a 4.7 kΩ resistor in series with the output of the MAX809 (Figure 15). If there are other components in the system which require a reset signal, they should be buffered so as not to load the reset line. If the other components are required to follow the reset I/O of the Microprocessor, the buffer should be connected as shown with the solid line.

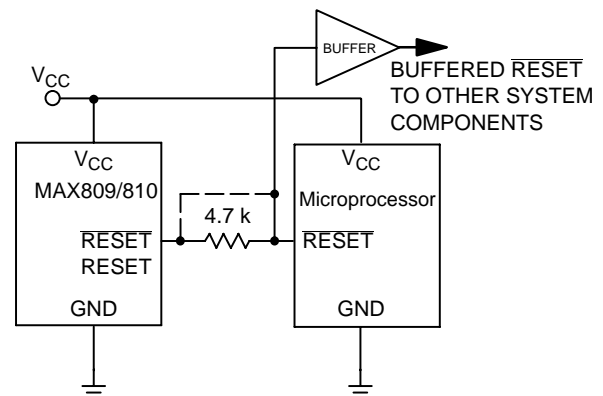

Figure 15. Interfacing to Bidirectional Reset I/O

MAX809 Series, MAX810 Series

ORDERING, MARKING AND THRESHOLD INFORMATION

Part Number	V _{TH} * (V)	Timeout* (ms)	Description	Marking	Package	Shipping†
MAX809SN160T1	1.60	140–460	Push–Pull RESET	SAA	SOT23–3	3000 / Tape & Reel
MAX809SN160T1G	1.60	140–460		SAA	SOT23–3 (Pb–Free)	
MAX809SN232T1	2.32	140–460		SQP	SOT23–3	
MAX809SN232T1G	2.32	140–460		SQP	SOT23–3 (Pb–Free)	
MAX809RTR	2.63	140–460		SPS	SOT23–3	
MAX809RTRG	2.63	140–460		SPS	SOT23–3 (Pb–Free)	
MAX809STR	2.93	140–460		SPT	SOT23–3	
MAX809STRG	2.93	140–460		SPT	SOT23–3 (Pb–Free)	
MAX809TTR	3.08	140–460		SPU	SOT23–3	
MAX809TTRG	3.08	140–460		SPU	SOT23–3 (Pb–Free)	
MAX809JTR	4.00	140–460		SPR	SOT23–3	
MAX809JTRG	4.00	140–460		SPR	SOT23–3 (Pb–Free)	
MAX809MTR	4.38	140–460		SPV	SOT23–3	
MAX809MTRG	4.38	140–460		SPV	SOT23–3 (Pb–Free)	
MAX809HTR	4.55	140–460		SBD	SOT23–3	
MAX809HTRG	4.55	140–460		SBD	SOT23–3 (Pb–Free)	
MAX809LTR	4.63	140–460		SPW	SOT23–3	
MAX809LTRG	4.63	140–460		SPW	SOT23–3 (Pb–Free)	
MAX809SN490T1	4.90	140–460		SBH	SOT23–3	
MAX809SN490T1G	4.90	140–460		SBH	SOT23–3 (Pb–Free)	
MAX809SN120T1G	1.20	140–460		SSO	SOT23–3 (Pb–Free)	
MAX809SN293D1T1G	2.93	1–3.3		SSP	SOT23–3 (Pb–Free)	
MAX809SN293D2T1G	2.93	20–66		SSQ	SOT23–3 (Pb–Free)	
MAX809SN293D3T1G	2.93	100–330		SSR	SOT23–3 (Pb–Free)	
MAX809SQ120T1G	1.20	140–460		ZD	SC70–3 (Pb–Free)	
MAX809SQ232T1G	2.32	140–460		ZE	SC70–3 (Pb–Free)	
MAX809SQ263T1G	2.63	140–460		ZF	SC70–3 (Pb–Free)	
MAX809SQ293T1G	2.93	140–460		ZG	SC70–3 (Pb–Free)	
MAX809SQ308T1G	3.08	140–460		ZH	SC70–3 (Pb–Free)	
MAX809SQ438T1G	4.38	140–460		ZI	SC70–3 (Pb–Free)	
MAX809SQ463T1G	4.63	140–460		ZJ	SC70–3 (Pb–Free)	
MAX809SQ293D1T1G	2.93	1–3.3		ZK	SC70–3 (Pb–Free)	
MAX809SQ293D2T1G	2.93	20–66	ZM	SC70–3 (Pb–Free)		
MAX809SQ293D3T1G	2.93	100–330	ZN	SC70–3 (Pb–Free)		

†For information on tape and reel specifications, including part orientation and tape sizes, please refer to our Tape and Reel Packaging Specifications Brochure, BRD8011/D.

*Contact your ON Semiconductor sales representative for other threshold voltage options.

MAX809 Series, MAX810 Series

ORDERING, MARKING AND THRESHOLD INFORMATION

Part Number	V _{TH} * (V)	Timeout* (ms)	Description	Marking	Package	Shipping†
MAX810RTR	2.63	140–460	Push–Pull RESET	SPX	SOT23–3	3000 / Tape & Reel
MAX810RTRG	2.63	140–460		SPX	SOT23–3 (Pb–Free)	
MAX810STR	2.93	140–460		SPY	SOT23–3	
MAX810STRG	2.93	140–460		SPY	SOT23–3 (Pb–Free)	
MAX810TTR	3.08	140–460		SPZ	SOT23–3	
MAX810TTRG	3.08	140–460		SPZ	SOT23–3 (Pb–Free)	
MAX810MTR	4.38	140–460		SQA	SOT23–3	
MAX810MTRG	4.38	140–460		SQA	SOT23–3 (Pb–Free)	
MAX810LTR	4.63	140–460		SQB	SOT23–3	
MAX810LTRG	4.63	140–460		SQB	SOT23–3 (Pb–Free)	
MAX810SN120T1G	1.20	140–460		SSS	SOT23–3 (Pb–Free)	
MAX810SN293D1T1G	2.93	1–3.3		SST	SOT23–3 (Pb–Free)	
MAX810SN293D2T1G	2.93	20–66		SSU	SOT23–3 (Pb–Free)	
MAX810SN293D3T1G	2.93	100–330		SSV	SOT23–3 (Pb–Free)	
MAX810SQ120T1G	1.20	140–460		ZN	SC70–3 (Pb–Free)	
MAX810SQ263T1G	2.63	140–460		ZO	SC70–3 (Pb–Free)	
MAX810SQ293T1G	2.93	140–460		ZP	SC70–3 (Pb–Free)	
MAX810SQ438T1G	4.38	140–460		ZQ	SC70–3 (Pb–Free)	
MAX810SQ463T1G	4.63	140–460		ZR	SC70–3 (Pb–Free)	
MAX810SQ293D1T1G	2.93	1–3.3		ZS	SC70–3 (Pb–Free)	
MAX810SQ293D2T1G	2.93	20–66	ZT	SC70–3 (Pb–Free)		
MAX810SQ293D3T1G	2.93	100–330	ZU	SC70–3 (Pb–Free)		

†For information on tape and reel specifications, including part orientation and tape sizes, please refer to our Tape and Reel Packaging Specifications Brochure, BRD8011/D.

*Contact your ON Semiconductor sales representative for other threshold voltage options.

MAX809 Series, MAX810 Series

PACKAGE DIMENSIONS

SOT-23 (TO236)
CASE 318-08
ISSUE AN

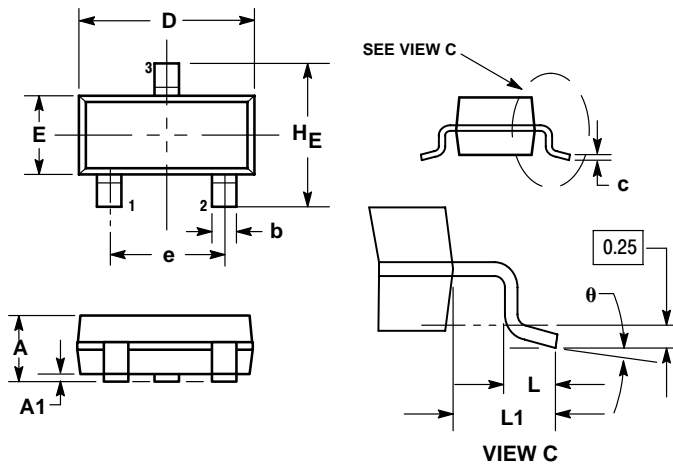

- NOTES:
1. DIMENSIONING AND TOLERANCING PER ANSI Y14.5M, 1982.
 2. CONTROLLING DIMENSION: INCH.
 3. MAXIMUM LEAD THICKNESS INCLUDES LEAD FINISH THICKNESS. MINIMUM LEAD THICKNESS IS THE MINIMUM THICKNESS OF BASE MATERIAL.
 4. 318-01 THRU -07 AND -09 OBSOLETE, NEW STANDARD 318-08.

DIM	MILLIMETERS			INCHES		
	MIN	NOM	MAX	MIN	NOM	MAX
A	0.89	1.00	1.11	0.035	0.040	0.044
A1	0.01	0.06	0.10	0.001	0.002	0.004
b	0.37	0.44	0.50	0.015	0.018	0.020
c	0.09	0.13	0.18	0.003	0.005	0.007
D	2.80	2.90	3.04	0.110	0.114	0.120
E	1.20	1.30	1.40	0.047	0.051	0.055
e	1.78	1.90	2.04	0.070	0.075	0.081
L	0.10	0.20	0.30	0.004	0.008	0.012
L1	0.35	0.54	0.69	0.014	0.021	0.029
HE	2.10	2.40	2.64	0.083	0.094	0.104

SOLDERING FOOTPRINT*

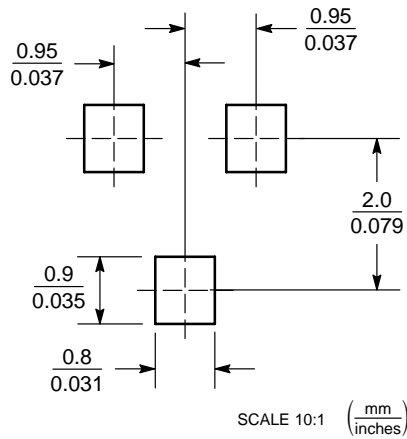

*For additional information on our Pb-Free strategy and soldering details, please download the ON Semiconductor Soldering and Mounting Techniques Reference Manual, SOLDERRM/D.

MAX809 Series, MAX810 Series

PACKAGE DIMENSIONS

SC-70 (SOT-323)
CASE 419-04
ISSUE M

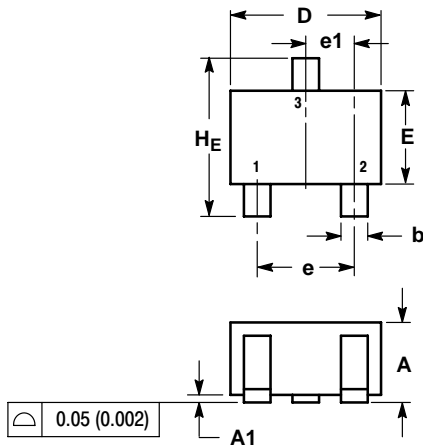

- NOTES:
1. DIMENSIONING AND TOLERANCING PER ANSI Y14.5M, 1982.
2. CONTROLLING DIMENSION: INCH.

DIM	MILLIMETERS			INCHES		
	MIN	NOM	MAX	MIN	NOM	MAX
A	0.80	0.90	1.00	0.032	0.035	0.040
A1	0.00	0.05	0.10	0.000	0.002	0.004
A2	0.7 REF			0.028 REF		
b	0.30	0.35	0.40	0.012	0.014	0.016
c	0.10	0.18	0.25	0.004	0.007	0.010
D	1.80	2.10	2.20	0.071	0.083	0.087
E	1.15	1.24	1.35	0.045	0.049	0.053
e	1.20	1.30	1.40	0.047	0.051	0.055
e1	0.65 BSC			0.026 BSC		
L	0.425 REF			0.017 REF		
HE	2.00	2.10	2.40	0.079	0.083	0.095

SOLDERING FOOTPRINT*

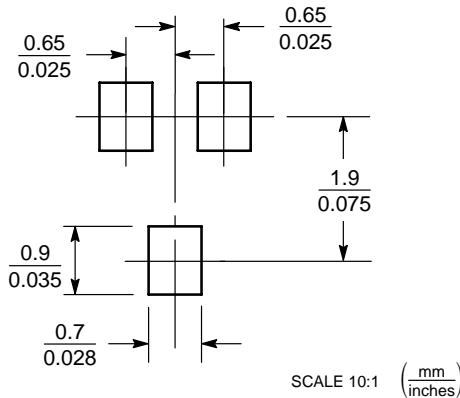

*For additional information on our Pb-Free strategy and soldering details, please download the ON Semiconductor Soldering and Mounting Techniques Reference Manual, SOLDERRM/D.

ON Semiconductor and are registered trademarks of Semiconductor Components Industries, LLC (SCILLC). SCILLC reserves the right to make changes without further notice to any products herein. SCILLC makes no warranty, representation or guarantee regarding the suitability of its products for any particular purpose, nor does SCILLC assume any liability arising out of the application or use of any product or circuit, and specifically disclaims any and all liability, including without limitation special, consequential or incidental damages. "Typical" parameters which may be provided in SCILLC data sheets and/or specifications can and do vary in different applications and actual performance may vary over time. All operating parameters, including "Typicals" must be validated for each customer application by customer's technical experts. SCILLC does not convey any license under its patent rights nor the rights of others. SCILLC products are not designed, intended, or authorized for use as components in systems intended for surgical implant into the body, or other applications intended to support or sustain life, or for any other application in which the failure of the SCILLC product could create a situation where personal injury or death may occur. Should Buyer purchase or use SCILLC products for any such unintended or unauthorized application, Buyer shall indemnify and hold SCILLC and its officers, employees, subsidiaries, affiliates, and distributors harmless against all claims, costs, damages, and expenses, and reasonable attorney fees arising out of, directly or indirectly, any claim of personal injury or death associated with such unintended or unauthorized use, even if such claim alleges that SCILLC was negligent regarding the design or manufacture of the part. SCILLC is an Equal Opportunity/Affirmative Action Employer. This literature is subject to all applicable copyright laws and is not for resale in any manner.

PUBLICATION ORDERING INFORMATION

LITERATURE FULFILLMENT:
Literature Distribution Center for ON Semiconductor
P.O. Box 61312, Phoenix, Arizona 85062-1312 USA
Phone: 480-829-7710 or 800-344-3860 Toll Free USA/Canada
Fax: 480-829-7709 or 800-344-3867 Toll Free USA/Canada
Email: orderlit@onsemi.com

N. American Technical Support: 800-282-9855 Toll Free
USA/Canada

Japan: ON Semiconductor, Japan Customer Focus Center
2-9-1 Kamimeguro, Meguro-ku, Tokyo, Japan 153-0051
Phone: 81-3-5773-3850

ON Semiconductor Website: <http://onsemi.com>

Order Literature: <http://www.onsemi.com/litorder>

For additional information, please contact your local Sales Representative.